

1.3 ACOPOS 1010, 1016

1.3.1 Order data



Model number	Short description	Images	
	Servo drives		
8V1010.00-2	Servo drive 3x 400-480V 1.0A 0.45kW, line filter, braking resistor and electronic secure restart inhibit integrated	 <p>8V1010.xxx-2</p>  <p>8V1016.xxx-2</p>	
8V1010.001-2	Servo drive 3x 400-480 V, 1.0 A, 0.45 kW, line filter, braking resistor and electronic secure restart inhibit integrated, coated		
8V1010.50-2	Servo drive 3x 110-230 V / 1x 110-230 V 2.0 A 0.45 kW, line filter, braking resistor and electronic secure restart inhibit integrated		
8V1010.501-2	Servo drive 3x 110-230 V / 1x 110-230 V 2.0 A 0.45 kW, line filter, braking resistor and electronic secure restart inhibit integrated, coated		
8V1016.00-2	Servo drive 3x 400-480V, 1.6A, 0.7kW, line filter, braking resistor and electronic secure restart inhibit integrated		
8V1016.001-2	Servo drive 3x 400-480V, 1.6A, 0.7kW, line filter, braking resistor and electronic secure restart inhibit integrated, coated		
8V1016.50-2	Servo drive 3x 110-230 V / 1x 110-230 V 3.2 A 0.7 kW, line filter, braking resistor and electronic secure restart inhibit integrated		
8V1016.501-2	Servo drive 3x 110-230 V / 1x 110-230 V 3.2 A 0.7 kW, line filter, braking resistor and electronic secure restart inhibit integrated, coated		

Table 9: Order data ACOPOS 1010, 1016

Optional accessories		
Model number	Short description	Page
8AC110.60-2	ACOPOS plug-in module, CAN interface	69
8AC114.60-2	ACOPOS plug-in module, POWERLINK V2 interface	72
8AC120.60-1	ACOPOS insert module, EnDat encoder and sine incremental encoder interface	76
8AC121.60-1	ACOPOS plug-in module, HIPERFACE interface	80
8AC122.60-3	ACOPOS plug-in module, resolver interface	83
8AC123.60-1	ACOPOS plug-in module, incremental encoder and SSI absolute encoder interface	86
8AC130.60-1	ACOPOS plug-in module, 8 digital I/O configurable in pairs as 24V input or as output 400/100mA, 2 digital outputs 2A, Order TB712 terminal block separately.	89
8AC131.60-1	ACOPOS plug-in module, 2 analog inputs $\pm 10V$, 2 digital I/O points which can be configured as a 24V input or 45mA output, order TB712 terminal block separately.	93
8AC140.60-2	ACOPOS plug-in module, CPU, x86 100MHz Intel compatible, 16 MB DRAM, 32kB SRAM, removable application memory: Compact Flash, 1 CAN interface, 1 Profibus DP slave interface, 1 RS232 interface, 3 digital I/O can be configured as 24 VDC input or 500 mA output, 1 analog input $\pm 10V$, order program memory and OTB708 terminal block separately.	97
8AC140.60-3	ACOPOS plug-in module, CPU, x86 100MHz Intel compatible, 32MB DRAM, 32kB SRAM, removable application memory: CompactFlash, 1 CAN interface, 1 Ethernet interface 100 Base-T, 1 Profibus DP slave interface, 1 RS232 interface, 3 digital I/O can be configured as 24 VDC input or 500 mA output, 1 analog input $\pm 10V$, order program memory and OTB708 terminal block separately.	97
8AC140.61-3	ACOPOS plug-in module, CPU, ARNC0, x86 100MHz Intel compatible, 32 MB DRAM, 32kB SRAM, removable application memory: CompactFlash, 1 CAN interface, 1 Ethernet interface 100 Base-T, 1 Profibus DP slave interface, 1 RS232 interface, 3 digital I/O can be configured as 24 VDC input or 500 mA output, 1 analog input $\pm 10V$, order program memory and OTB708 terminal block separately	97
8AC141.60-2	ACOPOS plug-in module, CPU, x86 100MHz Intel compatible, 16 MB DRAM, 32kB SRAM, removable application memory: CompactFlash, 2 CAN interfaces, 1 Ethernet interface 100 Base-T, 1 RS232 interface, 1 X2X Link Master interface, 3 digital I/O can be configured as 24 VDC input or output 500mA, 1 analog input $\pm 10V$, order program memory and OTB704 and OTB708 terminal blocks separately.	112
8AC141.61-3	ACOPOS plug-in module, CPU, ARNC0, x86 100MHz Intel compatible, 32 MB DRAM, 32kB SRAM, removable application memory: CompactFlash, 2 CAN interfaces, 1 Ethernet interface 100 Base-T, 1 RS232 interface, 1 X2X Link Master interface, 3 digital I/O can be configured as 24 VDC input or output 500mA, 1 analog input $\pm 10V$, order program memory and OTB704 and OTB708 terminal blocks separately	112
0PS320.1	24 VDC power supply, 3-phase, 20 A, input 400..500 VAC (3 phases), wide range, DIN rail mounting	
8CM005.12-1	Motor cable, length 5 m, 4 x 1.5 mm ² + 2 x 2 x 0.75 mm ² , Motor connector 8-pin Intercontec socket, can be used in drag chains, UL/CSA listed	126
8CM007.12-1	Motor cable, length 7m, 4 x 1.5 mm ² + 2 x 2 x 0.75 mm ² , Motor connector 8-pin Intercontec socket, can be used in drag chains, UL/CSA listed	126
8CM010.12-1	Motor cable, length 10m, 4 x 1.5 mm ² + 2 x 2 x 0.75 mm ² , Motor connector 8-pin Intercontec socket, can be used in drag chains, UL/CSA listed	126
8CM015.12-1	Motor cable, length 15m, 4 x 1.5 mm ² + 2 x 2 x 0.75 mm ² , Motor connector 8-pin Intercontec socket, can be used in drag chains, UL/CSA listed	126

Table 10: Optional accessories - ACOPOS 1010, 1016

1.3.2 Technical data

Product ID	8V1010.0xx-2	8V1016.0xx-2	8V1010.5xx-2	8V1016.5xx-2
General information				
C-UL-US listed	Yes			
Power mains connection				
Mains input voltage	3 x 400 VAC to 480 VAC ±10% Power filter according to IEC 61800-3-A11 second environment (Limits from CISPR11, Group 2, Class A)		3 x 110 VAC to 230 VAC ±10% or 1 x 110 VAC to 230 VAC ±10% Power filter according to IEC 61800-3-A11 second environment (Limits from CISPR11, Group 2, Class A)	
Frequency	50 / 60 Hz ± 4%		50 / 60 Hz ± 4%	
Installed load	Max. 1.35 kVA	Max. 2.1 kVA	Max. 1.35 kVA	Max. 2.1 kVA
Starting current	2 A (at 400 VAC)		5 A (at 230 VAC)	
Switch-on interval	> 10 s			
Power loss at max. device power without braking resistor	80 W	110 W	80 W	110 W
24 VDC supply				
Input Voltage ¹⁾	24 VDC +25% / -20%			
Input capacitance	5600 µF			
Current requirements ²⁾	Max. 1.47 A + current for motor holding brake			
DC bus				
DC bus capacitance	165 µF		2040 µF	
Motor connector				
Continuous current	1 A _{eff} ³⁾	1.6 A _{eff} ³⁾	2.3 A _{eff} ⁴⁾	3.6 A _{eff} ⁴⁾
Reduction of continuous current depending on ambient temperature ⁵⁾ Mains input voltage: 400 VAC Switching frequency 20 kHz Switching frequency 10 kHz Switching frequency 5 kHz Mains input voltage: 480 VAC Switching frequency 20 kHz Switching frequency 10 kHz Switching frequency 5 kHz	No reduction No reduction No reduction 0.13 A _{eff} per °C (starting at 45°C) No reduction No reduction	No reduction No reduction No reduction 0.13 A _{eff} per °C (starting at 40°C) No reduction No reduction	No reduction No reduction No reduction No reduction No reduction No reduction	No reduction No reduction No reduction No reduction No reduction No reduction
Reduction of continuous current depending on altitude Starting at 500 m above sea level	0.1 A _{eff} per 1,000 m	0.16 A _{eff} per 1,000 m	0.23 A _{eff} per 1,000 m	0.36 A _{eff} per 1,000 m
Peak Current	2.8 A _{eff}	5 A _{eff}	7.8 A _{eff}	12 A _{eff}
Rated switching frequency	10 kHz			
Maximum Motor Line Length	15 m			
Protective measures	Short circuit & overload protection			

Table 11: Technical data - ACOPOS 1010, 1016

Technical data • ACOPOS Servo Family

Product ID	8V1010.0xx-2	8V1016.0xx-2	8V1010.5xx-2	8V1016.5xx-2
Motor holding brake connection				
Maximum output current	1.3 A			
Max. number of switching cycles	Unlimited since done electronically			
Braking resistor				
Peak power output	2 kW	2 kW	1.9 kW	1.9 kW
Continuous power	130 W			
Trigger inputs				
Number of inputs	2			
Wiring	Sink			
Electrical isolation Input - ACOPOS Input - Input	Yes No			
Input voltage Rated Maximum	24 VDC 30 VDC			
Switching threshold LOW HIGH	<5 V >15 V			
Input current at rated voltage	Approx. 10 mA			
Switching delay Positive edge Negative edge	52 μ s \pm 0.5 μ s (digitally filtered) 53 μ s \pm 0.5 μ s (digitally filtered)			
Modulation compared to ground potential	Max. \pm 38 V			
Limit switch and reference inputs				
Number of inputs	3			
Wiring	Sink			
Electrical isolation Input - ACOPOS Input - Input	Yes No			
Input voltage Rated Maximum	24 VDC 30 VDC			
Switching threshold LOW HIGH	<5 V >15 V			
Input current at rated voltage	Approx. 4 mA			
Switching delay	Max. 2.0 ms			
Modulation compared to ground potential	Max. \pm 38 V			

Table 11: Technical data - ACOPOS 1010, 1016 (Forts.)

Product ID	8V1010.0xx-2	8V1016.0xx-2	8V1010.5xx-2	8V1016.5xx-2
Enable input				
Number of inputs	1			
Wiring	Sink			
Electrical isolation Input - ACOPOS	Yes			
Input voltage Rated Maximum	24 VDC 30 VDC			
Switching threshold LOW HIGH	<5 V >15 V			
Input current at rated voltage	Approx. 30 mA			
Switching delay Enable 1 -> 0, PWM off Enable 0 -> 1, Ready for PWM	Max. 2.0 ms Max. 100 µs			
Modulation compared to ground potential	Max. ±38 V			
Operational conditions				
Ambient temperature during operation Max. ambient temperature	5 to 40°C +55°C ⁶⁾			
Relative humidity during operation	5 to 85%, non-condensing			
Installation at altitudes above sea level Maximum installation altitude ⁷⁾	0 to 500 m 2000 m			
Degree of pollution according to EN 60664-1	2 (non-conductive material)			
Overvoltage cat. according to IEC 60364-4-443:1999	II			
EN 60529 protection	IP20			
Storage and transport conditions				
Storage temperature	-25 to +55°C			
Relative humidity during storage	5 to 95%, non-condensing			
Transport temperature	-25 to +70°C			
Relative humidity during transport	95% at +40°C			

Table 11: Technical data - ACOPOS 1010, 1016 (Forts.)

Technical data • ACOPOS Servo Family

Product ID	8V1010.0xx-2	8V1016.0xx-2	8V1010.5xx-2	8V1016.5xx-2
Mechanical characteristics				
Dimensions				
Width	58.5 mm			
Height	257 mm			
Depth	220 mm			
Weight	2.5 kg	2.5 kg	2.5kg	2.5 kg

Table 11: Technical data - ACOPOS 1010, 1016 (Forts.)

- 1) When using motor holding brakes, the valid input voltage range is reduced. The input voltage range should be selected so that the proper supply voltage for the motor holding brake can be maintained.
- 2) The current requirements depend on the configuration of the ACOPOS servo drive.
- 3) Valid in the following conditions: Mains input voltage 400 VAC, nominal switching frequency, 40°C ambient temperature, installation altitudes < 500 m above sea level.
- 4) Valid in the following conditions: Mains input voltage 230 VAC, nominal switching frequency, 40°C ambient temperature, installation altitudes < 500 m above sea level.
- 5) The nominal switching frequency values for the respective ACOPOS servo drive are marked in bold.
- 6) Continuous operation of ACOPOS servo drives at ambient temperatures ranging from 40°C to max. 55°C is possible (taking the continuous current reductions listed into consideration), but results in a shorter lifespan.
- 7) Continuous operation of ACOPOS servo drives at altitudes ranging from 500 m to 2000 m above sea level is possible (taking the continuous current reductions listed into consideration). Additional requirements are to be arranged with B&R.

2. Dimension diagrams and installation dimensions

2.1 ACOPOS 1010, 1016

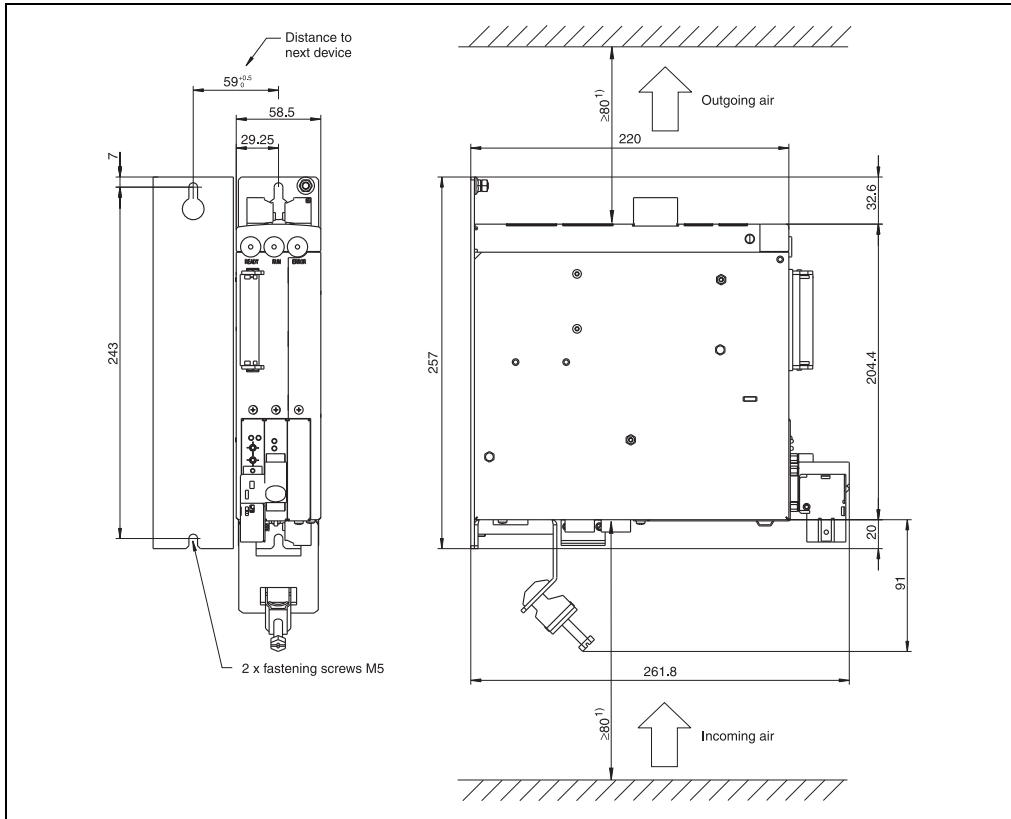

Figure 19: Dimensional diagram and installation dimensions for ACOPOS 1010, 1016

- 1) For proper air circulation, at least 80 mm has to be left free above and below the ACOPOS servo drive. Approximately 100 mm free space is required under the ACOPOS servo drive to prevent cabling problems.

1.5 Overview of the terminal cross sections ¹⁾

Connection	Wire types Approval data	8V1010.0xx-2 8V1010.5xx-2 8V1016.0xx-2 8V1016.5xx-2		8V1022.0xx-2 8V1045.0xx-2 8V1090.0xx-2		8V1180.0xx-2 8V1320.0xx-2		8V1640.0xx-2		8V128M.0xx-2	
		[mm ²]	[AWG]	[mm ²]	[AWG]	[mm ²]	[AWG]	[mm ²]	[AWG]	[mm ²]	[AWG]
X1	Solid core / multiple conductor lines	0.5 - 1.5	20 - 14	0.5 - 1.5	20 - 14	0.5 - 1.5	20 - 14	0.5 - 1.5	20 - 14	0.5 - 1.5	20 - 14
	Flexible and fine wire lines without wire tip sleeves with wire tip sleeves	0.5 - 1.5 0.5 - 1.5	20 - 14 20 - 14	0.5 - 1.5 0.5 - 1.5	20 - 14 20 - 14	0.5 - 1.5 0.5 - 1.5	20 - 14 20 - 14	0.5 - 1.5 0.5 - 1.5	20 - 14 20 - 14	0.5 - 1.5 0.5 - 1.5	20 - 14 20 - 14
	Approval data UL/C-UL-US CSA	---	26 - 14 26 - 14	---	26 - 14 26 - 14	---	26 - 14 26 - 14	---	26 - 14 26 - 14	---	26 - 14 26 - 14
Holding Torque for the Terminal Screws [Nm]		0.2 ... 0.25		0.2 ... 0.25		0.2 ... 0.25		0.2 ... 0.25		0.2 ... 0.25	
X2 DC bus	Solid core / multiple conductor lines	0.2 - 4	24 - 10	0.2 - 4	24 - 10	0.5 - 10	20 - 7	10 - 50	7 - 0	16 - 95	6 - 3/0
	Flexible and fine wire lines without wire tip sleeves with wire tip sleeves	0.2 - 4 0.25 - 4	24 - 10 23 - 10	0.2 - 4 0.25 - 4	24 - 10 23 - 10	0.5 - 6 0.5 - 6	20 - 9 20 - 9	10 - 35 10 - 35	7 - 2 7 - 2	10 - 70 10 - 70	7 - 2/0 7 - 2/0
	Approval data UL/C-UL-US CSA	---	30 - 10 28 - 10	---	30 - 10 28 - 10	---	20 - 8 20 - 8	---	10 - 2 12 - 2	---	6 - 2/0 6 - 2/0
Holding torque for the terminal screws [Nm]		0.5 ... 0.6		0.5 ... 0.6		1.2 ... 1.5		3 ... 4		6 ... 10	
X3 Mains	Solid core / multiple conductor lines	0.2 - 4	24 - 10	0.2 - 4	24 - 10	0.5 - 10	20 - 7	10 - 50	7 - 0	16 - 95	6 - 3/0
	Flexible and fine wire lines without wire tip sleeves with wire tip sleeves	0.2 - 4 0.25 - 4	24 - 10 23 - 10	0.2 - 4 0.25 - 4	24 - 10 23 - 10	0.5 - 6 0.5 - 6	20 - 9 20 - 9	10 - 35 10 - 35	7 - 2 7 - 2	10 - 70 10 - 70	7 - 2/0 7 - 2/0
	Approval data UL/C-UL-US CSA	---	30 - 10 28 - 10	---	30 - 10 28 - 10	---	20 - 8 20 - 8	---	10 - 2 12 - 2	---	6 - 2/0 6 - 2/0
Holding torque for the terminal screws [Nm]		0.5 ... 0.6		0.5 ... 0.6		1.2 ... 1.5		3 ... 4		6 ... 10	
X4a, X4b Motor (holding brake, temperature sensor)	Solid core / multiple conductor lines	0.2 - 2.5	24 - 12	0.2 - 2.5	24 - 12	0.2 - 2.5	24 - 12	0.2 - 2.5	24 - 12	0.2 - 2.5	24 - 12
	Flexible and fine wire lines without wire tip sleeves with wire tip sleeves	0.2 - 2.5 0.25 - 2.5	24 - 12 23 - 12	0.2 - 2.5 0.25 - 2.5	24 - 12 23 - 12	0.2 - 2.5 0.25 - 2.5	24 - 12 23 - 12	0.2 - 2.5 0.25 - 2.5	24 - 12 23 - 12	0.2 - 2.5 0.25 - 2.5	24 - 12 23 - 12
	Approval data UL/C-UL-US CSA	---	30 - 12 28 - 12	---	30 - 12 28 - 12	---	30 - 12 28 - 12	---	30 - 12 28 - 12	---	30 - 12 28 - 12
Holding torque for the terminal screws [Nm]		0.5 ... 0.6		0.5 ... 0.6		0.5 ... 0.6		0.5 ... 0.6		0.5 ... 0.6	
X5 Motor (power)	Solid core / multiple conductor lines	0.2 - 4	24 - 10	0.2 - 4	24 - 10	0.5 - 10	20 - 7	10 - 50	7 - 0	16 - 95	6 - 3/0
	Flexible and fine wire lines without wire tip sleeves with wire tip sleeves	0.2 - 4 0.25 - 4	24 - 10 23 - 10	0.2 - 4 0.25 - 4	24 - 10 23 - 10	0.5 - 6 0.5 - 6	20 - 9 20 - 9	10 - 35 10 - 35	7 - 2 7 - 2	10 - 70 10 - 70	7 - 2/0 7 - 2/0
	Approval data UL/C-UL-US CSA	---	30 - 10 28 - 10	---	30 - 10 28 - 10	---	20 - 8 20 - 8	---	10 - 2 12 - 2	---	6 - 2/0 6 - 2/0
Holding torque for the terminal screws [Nm]		0.5 ... 0.6		0.5 ... 0.6		1.2 ... 1.5		3 ... 4		6 ... 10	
X6 External braking resistor	Solid core / multiple conductor lines	---	---	---	---	0.2 - 4	24 - 10	0.5 - 10	20 - 7	0.5 - 10	20 - 7
	Flexible and fine wire lines without wire tip sleeves with wire tip sleeves	---	---	---	---	0.2 - 4 0.25 - 4	24 - 10 23 - 10	0.5 - 6 0.5 - 6	20 - 9 20 - 9	0.5 - 6 0.5 - 6	20 - 9 20 - 9
	Approval data UL/C-UL-US CSA	---	---	---	---	---	30 - 10 28 - 10	---	20 - 8 20 - 8	---	20 - 8 20 - 8
Holding torque for the terminal screws [Nm]		---		---		0.5 ... 0.6		1.2 ... 1.5		1.2 ... 1.5	

Table 114: Terminal cross sections for ACOPOS servo drives

1) ACOPOS 1022/1045/1090 revision I0 and up; ACOPOS 1180/1320 revision F0 and up; ACOPOS 1640 revision K0 and up; ACOPOS 128M revision C0 and up.

2. Pin assignments ACOPOS 1010, 1016

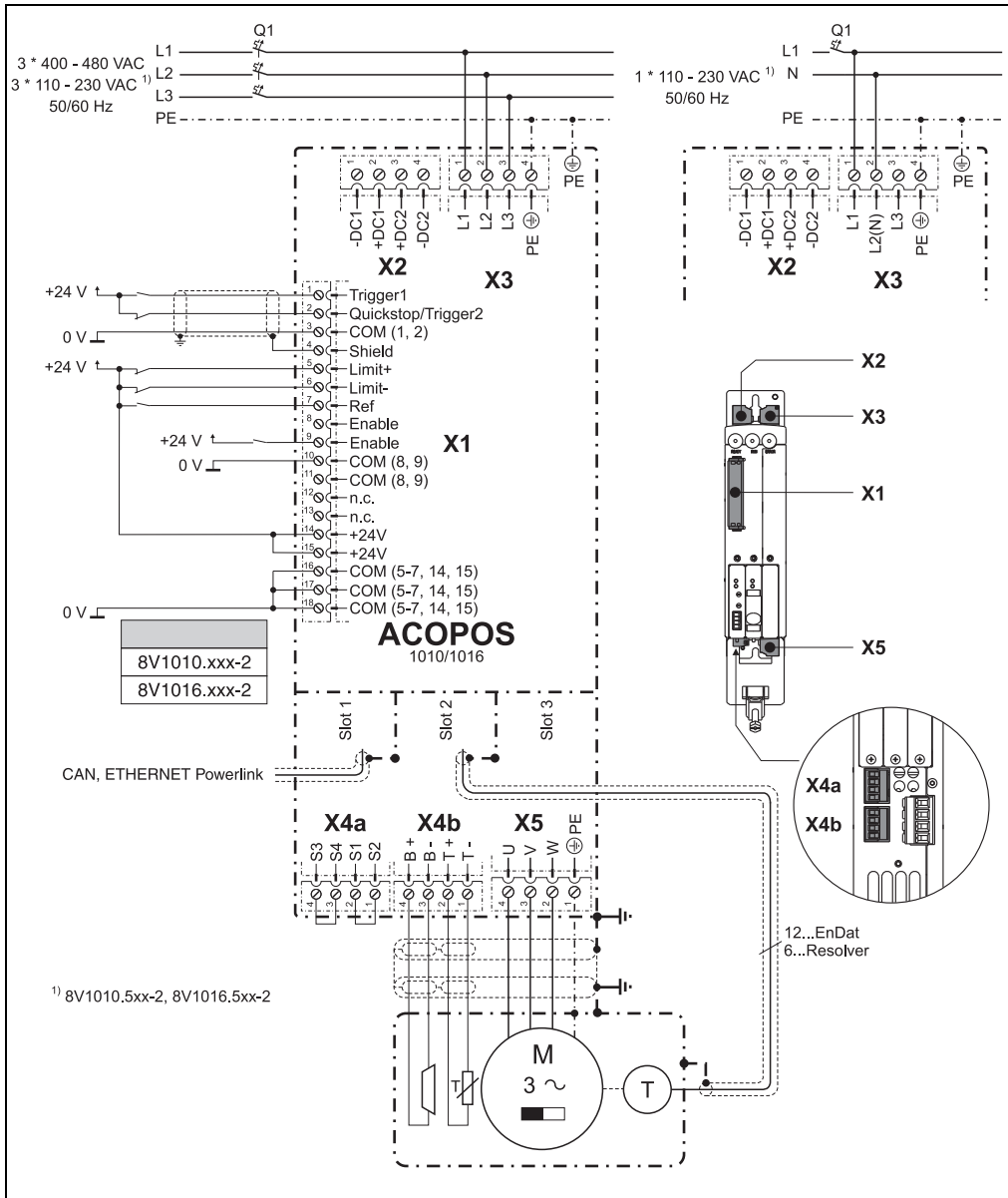

Figure 49: Overview of pin assignments ACOPOS 1010, 1016

2.1 Pin assignments - X1 plug

X1	Pin	Name	Function
	1	Trigger1	Trigger 1
	2	Quickstop/Trigger2	Quickstop/Trigger 2
	3	COM (1, 2)	Trigger 1, Quickstop/Trigger 2 0 V
	4	Shield	Shield
	5	Limit+	Positive HW limit
	6	Limit-	Negative HW limit
	7	Ref	Reference switch
	8	Enable	Enable
	9	Enable	Enable
	10	COM (8, 9)	Enable 0 V
	11	COM (8, 9)	Enable 0 V
	12	---	---
	13	---	---
	14	+24V	+24 V supply
	15	+24V	+24 V supply
	16	COM (5-7, 14, 15)	0 V supply
	17	COM (5-7, 14, 15)	0 V supply
	18	COM (5-7, 14, 15)	0 V supply
<p>The following connections are linked with each other internally in the device:</p> <ul style="list-style-type: none"> • Pin 8 --> Pin 9 (Enable) • Pin 10 --> Pin 11 (Enable 0 V) • Pin 14 --> Pin 15 (Supply +24 V) • Pin 16 --> Pin 17 --> Pin 18 (Supply 0 V) <p>Terminal cross sections see section 1.5 "Overview of the terminal cross sections" on page 228</p>			

Table 115: Pin assignments for plug X1 ACOPOS 1010, 1016

2.2 Pin assignments - X2 plug

2.2.1 8V1010.0xx-2, 8V1016.0xx-2

X2	Pin	Name	Function
	1	-DC1	U DC bus -
	2	+DC1	U DC bus +
	3	+DC2	U DC bus +
	4	-DC2	U DC bus -
Terminal cross sections see section 1.5 "Overview of the terminal cross sections" on page 228			

Table 116: Pin assignments for plug X2 ACOPOS 8V1010.00-2, 8V1016.00-2

2.2.2 8V1010.5xx-2, 8V1016.5xx-2

X2	Pin	Name	Function
	1	-DC1	U DC bus -
	2	+DC1	U DC bus +
	3	+DC2	U DC bus +
	4	-DC2	U DC bus -
Terminal cross sections see section 1.5 "Overview of the terminal cross sections" on page 228			

Table 117: Pin assignments for plug X2 ACOPOS 8V1010.50-2, 8V1016.50-2

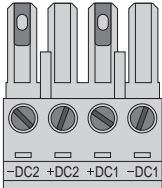
Warning!

Its only permitted to link DC buses for ACOPOS servo drives with the same supply voltage range (see table 90 "Supply voltage range for ACOPOS servo drives" on page 162).

Therefore, the DC buses for ACOPOS servo drives 8Vxxxx.5xx-2 and 8Vxxxx.0xx-2 are not allowed to be linked! For this reason, the X2 plugs for ACOPOS servo drives 8Vxxxx.5xx-2 and 8Vxxxx.0xx-2 are coded differently.

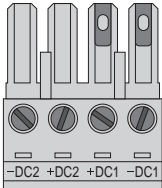
All ACOPOS servo drives 8Vxxxx.5xx-2 with a single-phase supply that should have their DC buses connected together must be connected to the same phase! If this is not done, the DC bus voltage increases to a level that is not permitted; this caused the devices to be destroyed!

2.3 Pin assignments - X3 plug

Danger!

Servo drives are not permitted to be operated directly on IT and TN-S mains with a grounded phase conductor and protective ground conductor!

2.3.1 8V1010.0xx-2, 8V1016.0xx-2

X3	Pin	Name	Function
	1	L1	Power mains connection L1
	2	L2	Power mains connection L2
	3	L3	Power mains connection L3
	4	PU	Protective ground conductor
Terminal cross sections see section 1.5 "Overview of the terminal cross sections" on page 228			

Table 118: Pin assignments for plug X3 ACOPOS 8V1010.00-2, 8V1016.00-2

2.3.2 8V1010.5xx-2, 8V1016.5xx-2

X3	Pin	Name	Function
	1	L1	Power mains connection L1
	2	L2(N)	Power mains connection N
	3	L3	---
	4	PU	Protective ground conductor
Terminal cross sections see section 1.5 "Overview of the terminal cross sections" on page 228			

Table 119: Pin assignments for plug X3 ACOPOS 8V1010.50-2, 8V1016.50-2

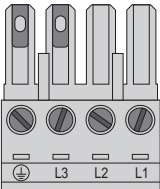
2.4 Pin assignments for plugs X4a, X4b

X4a	Pin	Name	Function
 <p>S3 S4 S1 S2</p>	1	S2 ¹⁾	Activation, supply for the external holding brake (+)
	2	S1 ¹⁾	Activation for the external holding brake (+)
	3	S4	Activation, supply for the external holding brake (-)
	4	S3	Activation for the external holding brake (-)
Terminal cross sections see section 1.5 "Overview of the terminal cross sections" on page 228			

Table 120: Pin assignments for plug X4a ACOPOS 1010, 1016

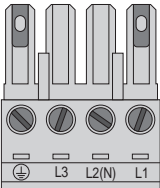
- 1) If the holding brake is connected via an additional external relay contact (ground-in e.g. via the connections S1/S2) instead of via the internal transistor, then the internal quenching circuit has no effect! In this case, the customer must make sure that neither the relay contact nor the braking coil are damaged when switching off the brake. This can be done by interconnecting the coil or - better still - interconnecting the contact with a quenching circuit.

X4b	Pin	Name	Function
 <p>B+ B- T+ T-</p>	1	T-	Temperature sensor -
	2	T+	Temperature sensor +
	3	B- ¹⁾	Brake -
	4	B+ ¹⁾	Brake +
Terminal cross sections see section 1.5 "Overview of the terminal cross sections" on page 228			

Table 121: Pin assignments for plug X4b ACOPOS 1010, 1016

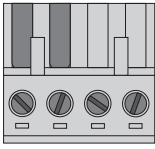
- 1) If the holding brake is connected via an additional external relay contact (ground-in e.g. via the connections S1/S2) instead of via the internal transistor, then the internal quenching circuit has no effect! In this case, the customer must make sure that neither the relay contact nor the braking coil are damaged when switching off the brake. This can be done by interconnecting the coil or - better still - interconnecting the contact with a quenching circuit.

2.4.1 Wiring the output for the motor holding brake

The supply, activation and monitoring of the output for the motor holding brake can take place via the the X4a connector in three different ways:

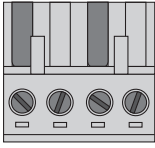
Figure	Description
<p>1</p> 	<ul style="list-style-type: none"> • Supply: Internally by the ACOPOS servo drive • Activation: Internally by the ACOPOS servo drive • Monitoring: Internally by the ACOPOS servo drive <p>A jumper must be placed between S1 and S2 as well as S3 and S4 on the X4a connector. ¹⁾</p>
<p>2</p> 	<ul style="list-style-type: none"> • Supply: Internally by the ACOPOS servo drive • Activation: Internally by the ACOPOS servo drive and also possible externally using potential free contacts ²⁾ • Monitoring: Internally by the ACOPOS servo drive <p>Information: The parameters for ACOPOS internal monitoring must be set according to the requirements of the application. ³⁾</p>
<p>3</p> 	<ul style="list-style-type: none"> • Supply: External • Activation: External • Monitoring: External <p>Information: ACOPOS internal monitoring cannot be used here; therefore it must be deactivated using software. ⁴⁾</p>

Table 122: Activation for the external holding brake

- 1) Both jumpers are already on the X4a connector delivered with the ACOPOS servo drives.
- 2) External potential free contacts can be connected between S1 and S2 as well as between S3 and S4. This makes it possible to activate the holding brake using an external safety circuit independent of the control integrated in the ACOPOS servo drive.
- 3) The parameters are set using ParID 90 (1 ... internal monitoring active; 5 ... internal monitoring not active).
- 4) Deactivation takes place using ParID 90 (5 ... internal monitoring not active).

2.5 Pin assignments - X5 plug

X5	Pin	Name	Function
	1	PU	Protective ground conductor
	2	W	Motor connection W
	3	V	Motor connection V
	4	U	Motor connection U
Terminal cross sections see section 1.5 "Overview of the terminal cross sections" on page 228			

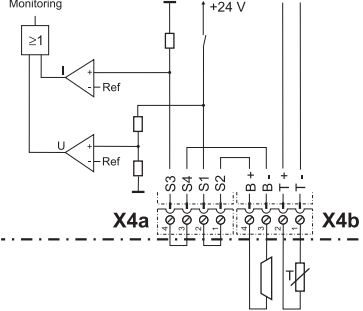
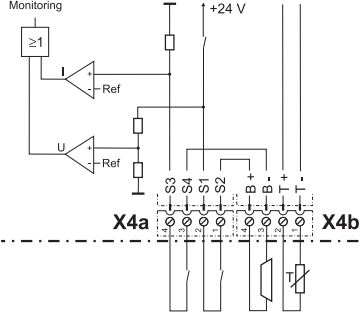
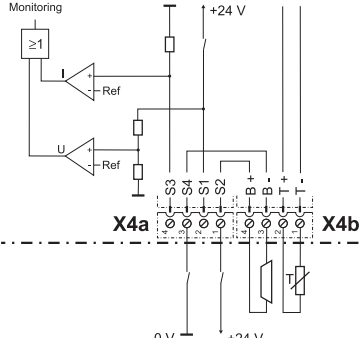
Table 123: Pin assignments for plug X5 ACOPOS 1010, 1016

2.6 Additional protective ground connection (PE)

The protective ground conductor is connected to the threaded bolt M5 provided using a cable lug. For information concerning dimensioning see section 1.1.3 "Protective ground connection (PE)" on page 162.

Figure	Pin	Name	Function
	---	PU	Protective ground conductor
	Terminal cross sections		
		[mm ²]	AWG
Cable lug for threaded bolt M5		0.25 - 16	23 - 5

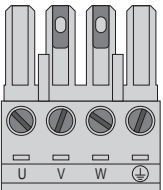
Table 124: Protective ground conductor (PE) ACOPOS 1010, 1016

Danger!

Before turning on the servo drive, make sure that the housing is properly connected to ground (PE rail). The ground connection must be made, even when testing the servo drive or when operating it for a short time!

2.7 Input/output circuit diagram

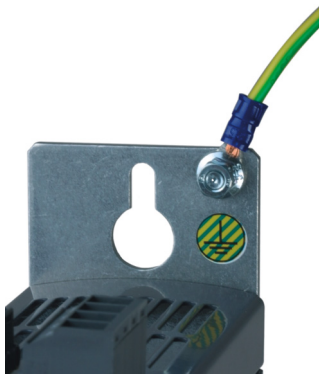
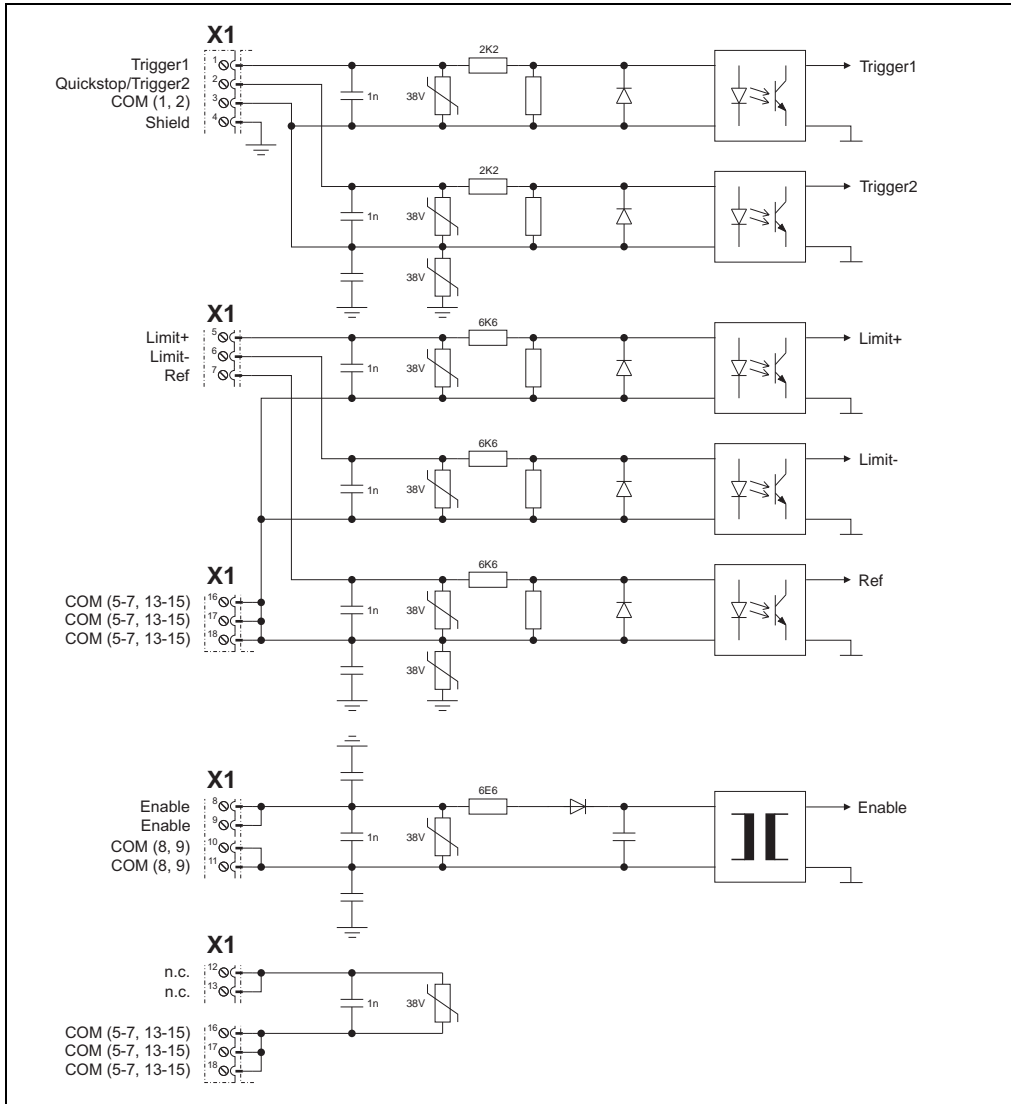

Figure 50: Input/Output Circuit Diagram ACOPOS 1010, 1016

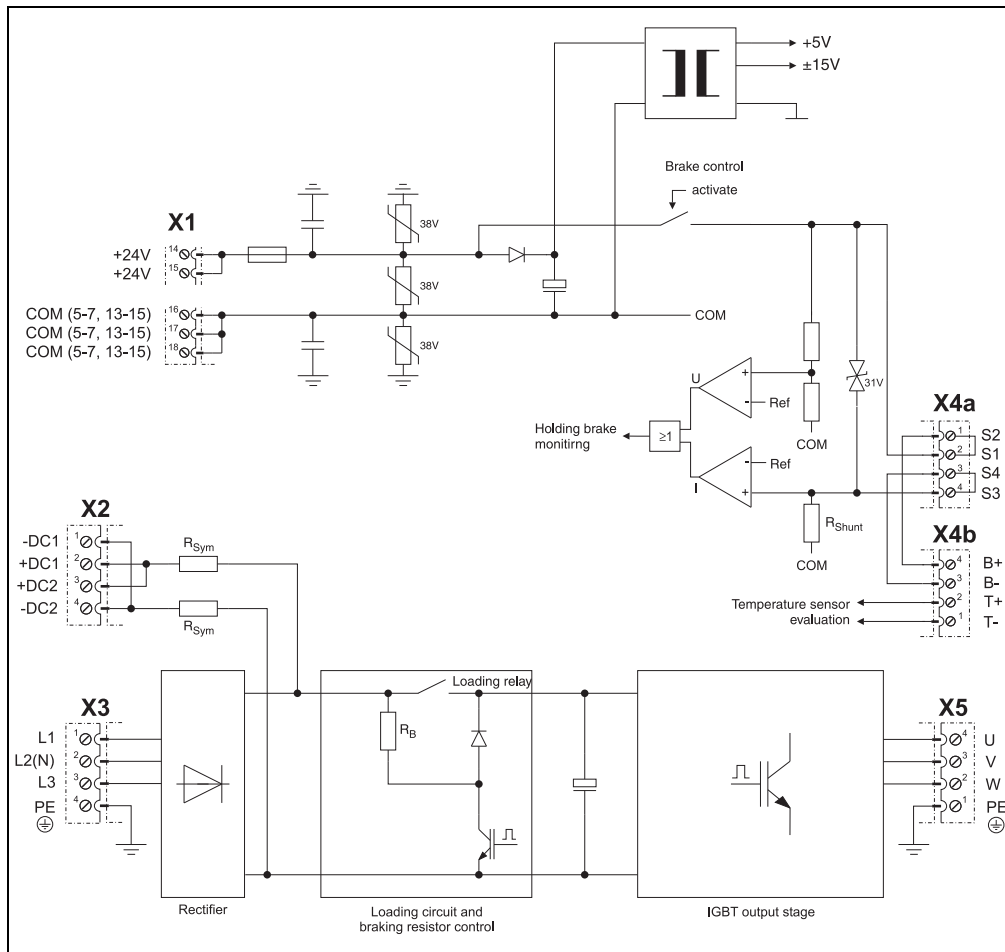

Figure 50: Input/Output Circuit Diagram ACOPOS 1010, 1016 (Forts.)