

Model 6553
Hydrogen Purity
Gas Analyser System

Instruction Manual
4689 503 Digital Display



ABB Kent-Taylor



ABB KENT-TAYLOR

The Company

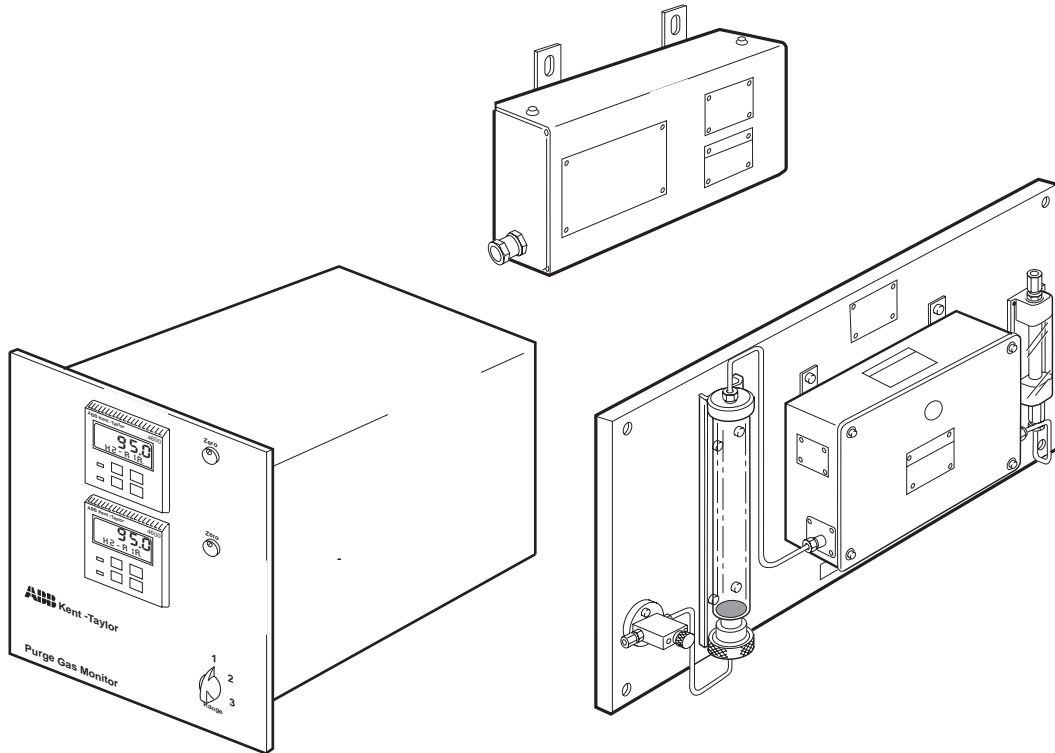
ABB Kent-Taylor is an established world force in the design and manufacture of instrumentation for industrial process control, flow measurement, gas and liquid analysis and environmental applications.

As a part of ABB, a world leader in process automation technology, we offer customers application expertise, service and support worldwide.

We are committed to teamwork, high quality manufacturing, advanced technology and unrivalled service and support.

The quality, accuracy and performance of the Company's products result from over 100 years experience, combined with a continuous program of innovative design and development to incorporate the latest technology.

The NAMAS Calibration Laboratory No. 0255(B) is just one of the ten flow calibration plants operated by the Company, and is indicative of ABB Kent-Taylor's dedication to quality and accuracy.

BS EN ISO 9001



St Neots, U.K. – Cert. No. Q5907
Stonehouse, U.K. – Cert. No. FM 21106

EN 29001 (ISO 9001)



Lenno, Italy – Cert. No. 9/90A



Stonehouse, U.K. – Cert. No. 0255

Use of Instructions



Warning.

An instruction that draws attention to the risk of injury or death.



Caution.

An instruction that draws attention to the risk of damage to the product, process or surroundings.



Note.

Clarification of an instruction or additional information.



Information.

Further reference for more detailed information or technical details.

Although **Warning** hazards are related to personal injury, and **Caution** hazards are associated with equipment or property damage, it must be understood that operation of damaged equipment could, under certain operational conditions, result in degraded process system performance leading to personal injury or death. Therefore, comply fully with all **Warning** and **Caution** notices.

Information in this manual is intended only to assist our customers in the efficient operation of our equipment. Use of this manual for any other purpose is specifically prohibited and its contents are not to be reproduced in full or part without prior approval of Technical Communications Department, ABB Kent-Taylor.

Health and Safety

To ensure that our products are safe and without risk to health, the following points must be noted:

1. The relevant sections of these instructions must be read carefully before proceeding.
2. Warning labels on containers and packages must be observed.
3. Installation, operation, maintenance and servicing must only be carried out by suitably trained personnel and in accordance with the information given.
4. Normal safety precautions must be taken to avoid the possibility of an accident occurring when operating in conditions of high pressure and/or temperature.
5. Chemicals must be stored away from heat, protected from temperature extremes and powders kept dry. Normal safe handling procedures must be used.
6. When disposing of chemicals ensure that no two chemicals are mixed.

Safety advice concerning the use of the equipment described in this manual or any relevant hazard data sheets (where applicable) may be obtained from the Company address on the back cover, together with servicing and spares information.

CONTENTS

Section	Page	Section	Page
1 INTRODUCTION	2	9 OPERATION	17
2 DESCRIPTION		9.1 Normal	17
2.1 Model 4689 603 Display Unit	2	9.2 Purging of Hydrogen Coolant Gas	17
2.2 Zener Barrier Units	2	9.3 Filling with Hydrogen Coolant Gas	17
2.3 Model 6640 203 Katharometer Analyzer Panel	2	9.4 Operating Page	17
2.4 Model 4234 Power Supply Unit	3		
3 PREPARATION	4	10 PROGRAMMING	18
3.1 Identification	4	10.1 Access to Secure Parameters	19
3.1.1 Model 4689 603 Display Unit	4	10.2 Set Up Outputs Page	19
3.1.2 Model 6640 203 Katharometer Analyzer Panel	4	10.3 Calibration Page	20
3.1.3 Model 4234 Power Supply Unit	6	10.4 Access Page	20
4 MECHANICAL INSTALLATION	6	11 MAINTENANCE	22
4.1 Locating and Mounting System Items	6	11.1 General Maintenance	22
4.1.1 Model 4689 603 Display Unit	6	11.1.1 Pressure	22
4.1.2 Model 6640 203 Katharometer Analyzer Panel	6	11.1.2 Flow	22
4.1.3 Model 4234 Power Supply Unit	7	11.1.3 Leaks	22
4.2 Sample Gas Interconnections	7	11.1.4 Vibration	22
		11.1.5 Contamination	22
		11.1.6 Ambient Temperature	22
		11.1.7 Bridge Current	22
		11.2 Diagnostic Tests	22
		11.2.1 Checking Output of 4234 Power Supply Unit	22
		11.2.2 Checking Integrity of Zener Barrier Units	22
		11.2.3 Checking the Katharometer Output	22
		11.3 Routine Maintenance	22
		11.3.1 Hydrogen Katharometer Calibration	22
		11.3.2 Changing Desiccant in Drying Chamber	22
		11.4 Repair Maintenance	23
		11.4.1 Removing Liquid from Katharometer Measurement Block	23
5 ELECTRICAL INSTALLATION	8	12 SPARE PARTS LIST	24
5.1 Electrical Interconnections	8	12.1 Consumables	24
5.1.1 Model 4689 603 Display Unit	8	12.2 Routine Maintenance Parts	24
5.1.2 Model 6640 203 Katharometer Analyzer Panel	9	12.3 Repair Maintenance Parts	24
5.1.3 Model 4234 Power Supply Unit	10		
5.2 Intrinsically Safe Requirements	10	13 SPECIFICATION	25
5.2.1 Cable Requirements	10		
5.2.2 Recommended Cables	12	APPENDIX	27
5.2.3 Full Intrinsically Safe Requirements	12	A1.1 Model 4234 Power Supply Unit	27
		A1.1.1 Functional Description	27
		A1.1.2 Fault Finding	27
		A1.1.3 Parts List	27
6 SETTING UP	13		
6.1 Katharometer Analyzer Panel - Filling the Drying Chamber	13		
6.2 Setting Sample Flow	13		
6.3 Electrical Checks	14		
6.3.1 Model 4234 Power Supply Unit Output	14		
6.3.2 Zener Barrier Units	14		
6.3.3 Checking System Earth	14		
7 CONTROLS AND DISPLAYS	15		
7.1 Displays	15		
7.2 Switch Familiarization	15		
8 START-UP	16		
8.1 Instrument Start-up	16		
8.2 Alarm Set-points	16		
8.2.1 Type of Alarm Action	16		
8.2.2 Hydrogen	16		
8.3 Calibration	16		
8.3.1 Hydrogen	16		

1 INTRODUCTION



Warning. This operating manual applies only to those systems which have been designed and constructed to the standards specified in the schedules of the BASEEFA certificates listed. The separate units to which these certificates apply are clearly identifiable by model numbers and the data on the identification and BASEEFA certification labels fixed to them. Other combinations of similar equipment built to any earlier specifications are not covered by certificate number EX 77138. This is particularly important where new replacement units are to be incorporated into existing installations covered by any earlier certification standards. If in any doubt about the installation of particular combinations of certified equipment, please contact the Company for advice before proceeding. It is essential that units are installed strictly in accordance with the appropriate standards for electrical equipment for use in flammable atmospheres. Any deviation from the specified installation conditions, or any unauthorized repairs or adjustments can invalidate the safety assurances given by the certification of the unit.

The ultimate responsibility for any particular installation lies with the installing user/contractor.

This manual gives the installation, operating and maintenance information for a Hydrogen Purity System, normally used with hydrogen cooled electrical power generators.

The system uses a combination of three different units. Each unit is independently certified by BASEEFA (EECS) for use as part of an intrinsically safe system to the standards of SFA.3012:1972 for use in association with Group IIC (hydrogen) hazardous atmospheres. The different units of the system are:

- 1) **The Gas Monitor Unit.** The input to this unit is certified to code Ex(i)aIIC under BASEEFA certificate Ex 77124/B/S with the unit installed in the safe area only.
- 2) **The Model 6539-960 or 6539-970 Katharometer Units.** One of these units forms part of the intrinsically safe Model 6540-203 Katharometer Analyzer Panel. The units are certified to code Ex (ia) IIC T5 under BASEEFA certificate Ex 76179/B for installation in the hazardous area. The katharometers may or may not be fitted with ignition arrestors in the sample connection lines, depending on user requirements.
- 3) **The Model 4234 constant current Power Supply Unit.** This provides a suitable supply for the katharometer unit. The unit has its output certified to code Ex (ia) IIC T5 under BASEEFA certificate Ex 76180/B/S for installation in the safe area only.

The complete gas monitoring system, if installed in accordance with the certificate schedules and the requirements given in this manual, is itself certified intrinsically safe to an overall code Ex (ia) IIC under the system certificate number Ex 77138.

If further information or assistance is required, Company specialist staff, service centres or worldwide organization may be contacted through the most convenient address given on the

2 DESCRIPTION

back cover of this manual. Specialist training courses can also be arranged by our Training Centre.

Three units are supplied as separate items to form the Hydrogen Purity System when interconnected.

2.1 Model 4689 503 Display Unit

The display is suitable for mounting in the **safe area**.

2.2 Zener Barrier Units

The zener barrier units limit the electrical energy level that can be applied from the instrument circuits into the **hazardous area**.

2.3 Model 6540 203 Katharometer Analyzer Panel

The gas monitoring system is certified for hydrogen purity and there is a katharometer analyzer panel in the **hazardous area**.

The panel has a katharometer assembly which comprises a thermally lagged katharometer type 6539-960, a metering valve, a flowmeter and a drying chamber. These items are mounted on a flat panel suitable for fixing to a vertical surface close to the sample point – see Fig. 2.1.

The katharometer is calibrated for hydrogen purity measurement.

The inlet and outlet gas unions to the katharometer unit may be provided with ignition arresters (Model 6540 203/J), but these are not a necessary part of the certification. The katharometer analyzer panel not provided with ignition arresters is the Model 6540 203/K.

The sealed katharometer assembly incorporates a Wheatstone Bridge made up of fine, glass-coated platinum filaments. One pair of parallel arms is sealed in reference gas (hydrogen) and the other pair exposed to the sample gas.

When the intrinsically safe stabilised current from the power supply unit (Model 4234) is passed through this bridge, the temperature of the platinum filaments rises to a point of thermal equilibrium. Under conditions which are arranged to give minimum radiation and convection heat transfer, the equilibrium temperature depends on the thermal conductivity of the gas surrounding the filament. Thus any difference between the thermal conductivity of reference and sample gases causes an imbalance in the bridge; this imbalance (as a millivolt signal) is indicated by the display unit.

Zener diodes are connected across the input connections from the power supply unit to the katharometer in order to limit the maximum voltage which could be developed across the filament bridge under external fault conditions. The current is

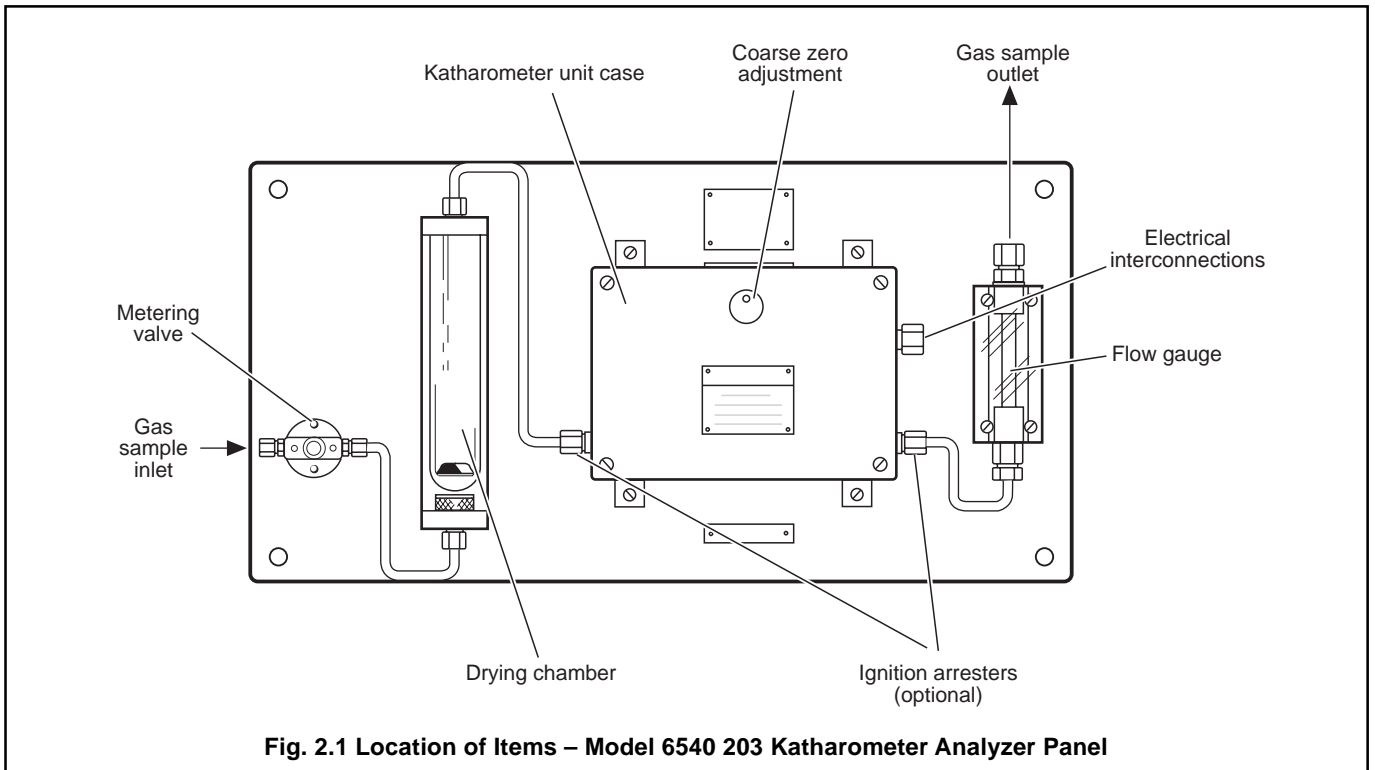

Fig. 2.1 Location of Items – Model 6540 203 Katharometer Analyzer Panel

limited to a safe value under fault conditions by the power supply unit.

2.4 Model 4234 Power Supply Unit

Each katharometer unit operating in the **hazardous area**, requires a separate Model 4234 Power Supply Unit. The Power Supply Unit supplies a stabilized 350 mA d.c. signal, and must be mounted in the **safe area**. There are two separate versions available for either a nominal 110 to 120V a.c. or a nominal 200 to 220/240V a.c. supply voltage. The stabilized current output is current and voltage limited to restrict the

energy supply into the hazardous area.

The model 4234 is housed in a metal case fitted with lugs for wall/panel mounting. Cable gland entries are provided at opposite ends of the case for supply voltage input and stabilized output cables to the hazardous area. The printed circuit board assembly and diode heat sink are mounted on a metal chassis and separate labelled terminal blocks are used for making electrical interconnections.

3 PREPARATION

The circuit is protected by a cartridge fuse which must have a high breaking capacity (hbc) rating of 4000A to comply with the terms of the certification.

3.1 Identification

It is essential that installers and users identify the various units of the monitoring system as follows:

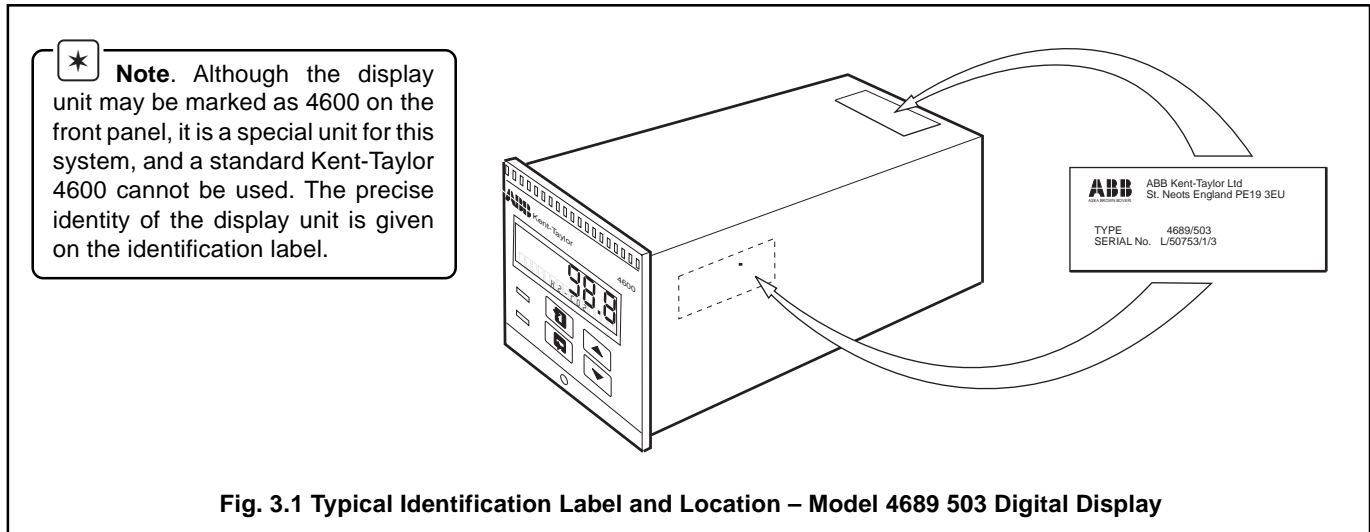

3.1.1 Model 4689 503 Display Unit – Fig. 3.1

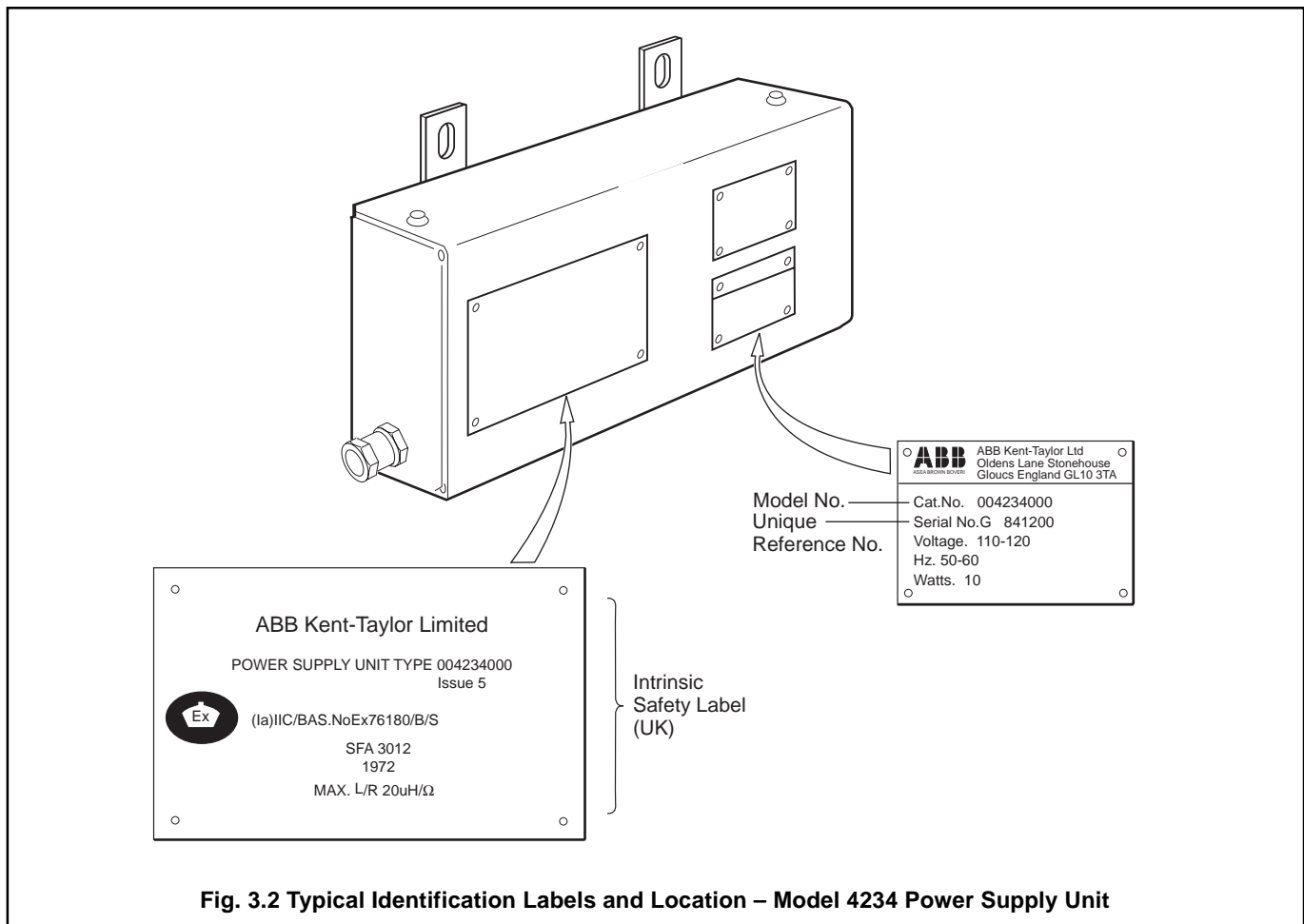

3.1.2 Model 4234 Power Supply Unit – Fig. 3.2

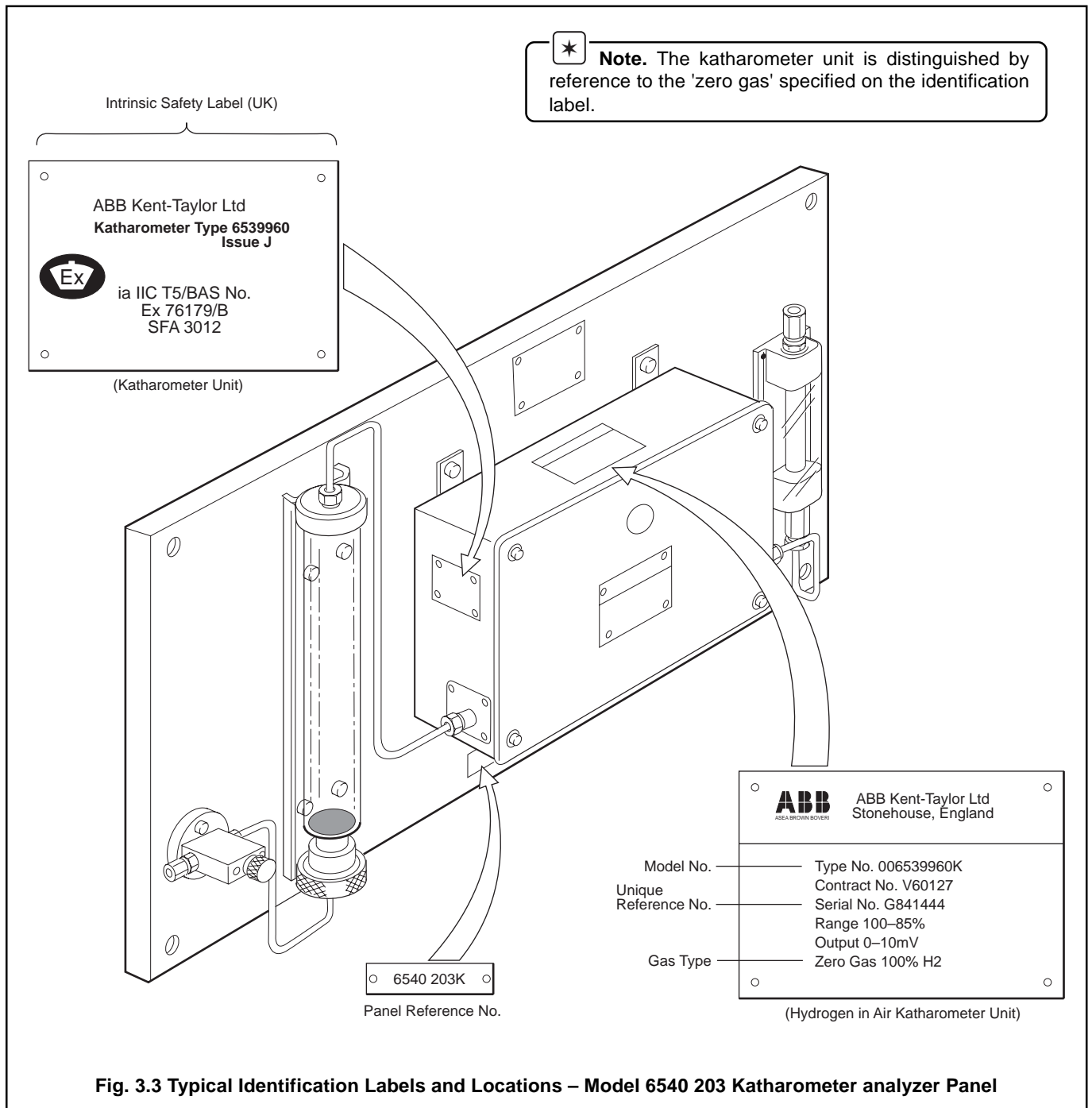

Fig. 3.3 Typical Identification Labels and Locations – Model 6540 203 Katharometer analyzer Panel

4 MECHANICAL INSTALLATION

3.1.3 Model 6540 203 Katharometer Analyzer Panel – Fig. 3.3

4.1 Locating and Mounting System Items

4.1.1 Model 4689 503 Display Unit – Fig. 4.1

The unit must be located in the **safe** area of the application plant in a sheltered interior environment, and is intended to be mounted in a position to suit reading of the display, and with access to the rear, to enable wiring interconnections to be made.

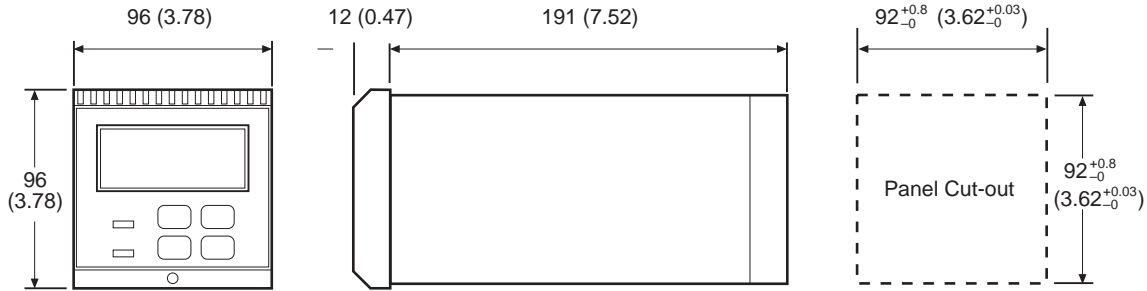

Fig. 4.1 Installation Dimensions – Model 4689 503 Display Unit

4.1.2 Model 6540 203 Katharometer Analyzer Panel – Fig. 4.2



Caution. Ensure that the panel specifying zero gas 'Hydrogen', is located at the required position.

The panel is located in the **hazardous** area (zone 0,1 or 2) of the application plant in a sheltered interior environment. Avoid a location which subjects the katharometer unit to direct sunlight.

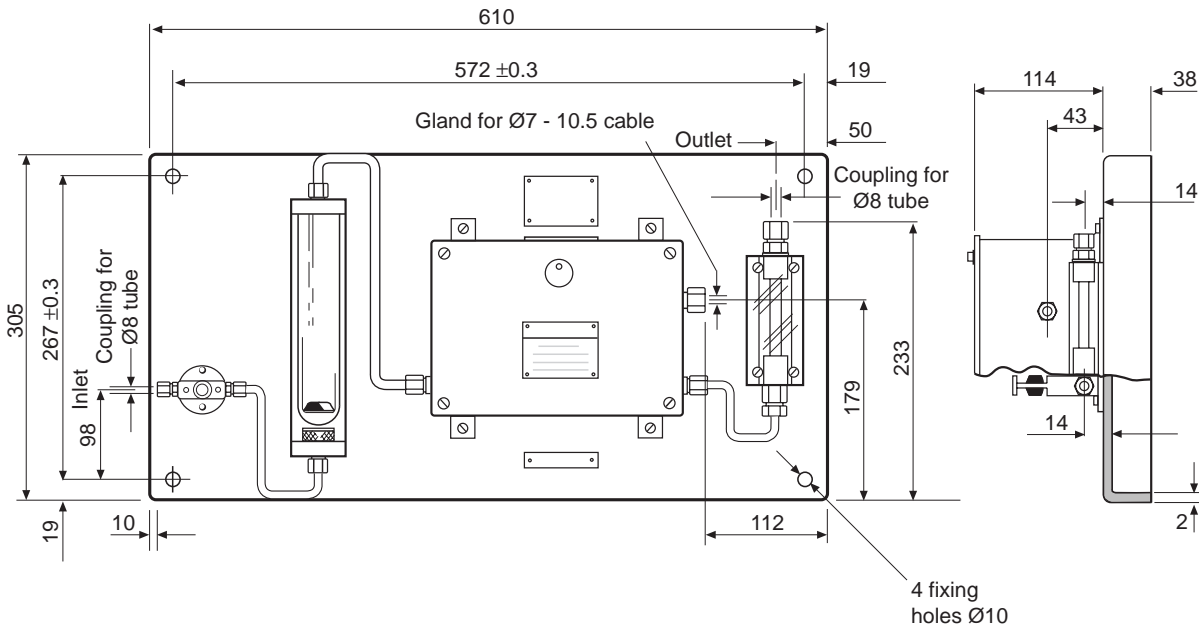

Fig. 4.2 Installation Dimensions and Interconnection Positions – Model 6540 203 Katharometer Analyzer Panel

The katharometer unit is fixed to the panel which has fixing holes at each corner and should be mounted on a suitable vertical surface close to the sample tapping point.

4.1.3 Model 4234 Power Supply Unit – Fig. 4.3

The unit must be located in the **safe** area of the application plant in a sheltered interior environment. It has four fixing lugs and should be mounted on a suitable vertical surface.

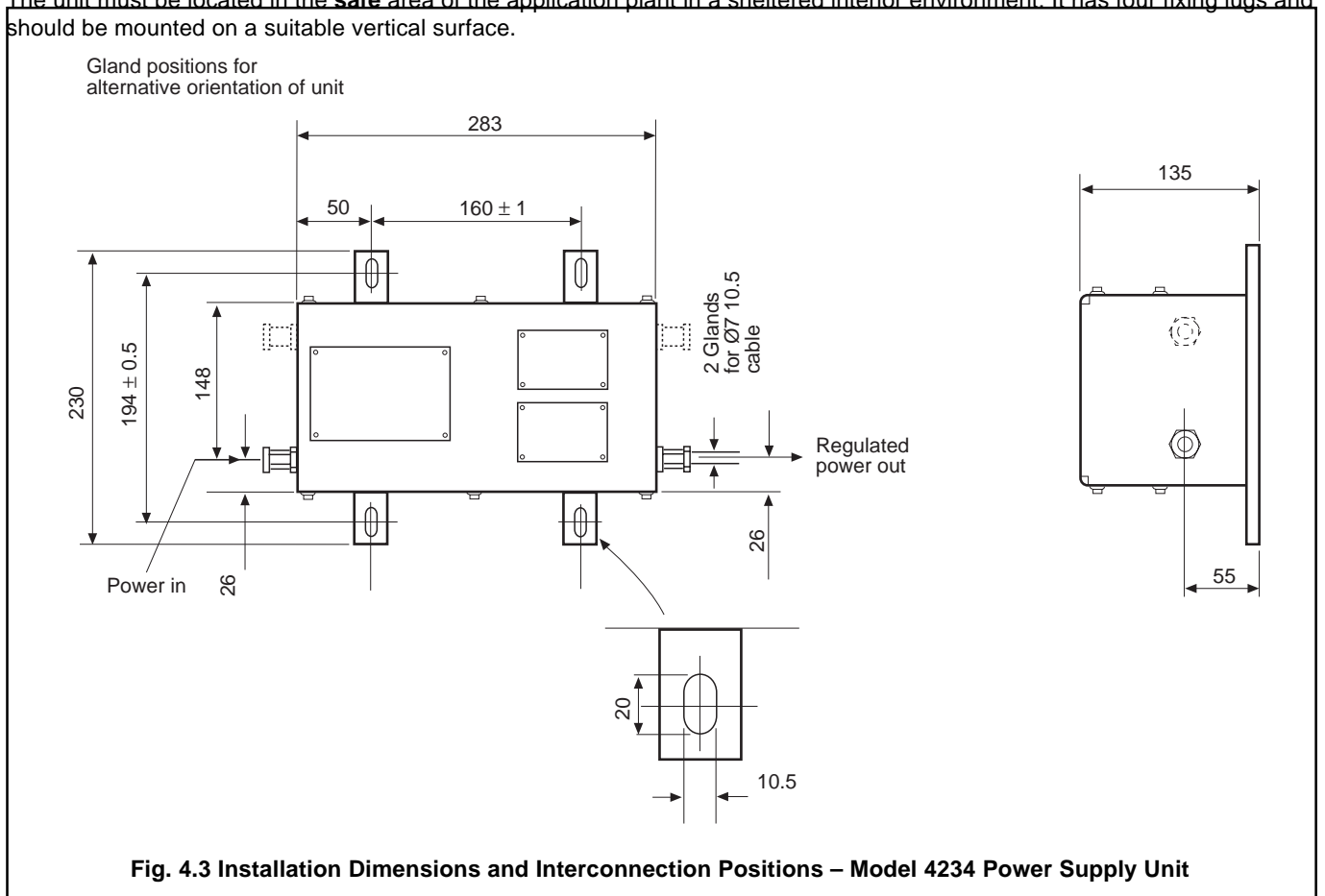

Fig. 4.3 Installation Dimensions and Interconnection Positions – Model 4234 Power Supply Unit

4.2 Sample Gas Interconnections



Warning. A hazardous mixture of hydrogen in air could develop in the event of leakage from the sample gas system. Katharometer analyzer panels should be located in a ventilated area.

The sample pressure must not exceed the value given in Section 13.

The incoming sample gas temperature must not exceed the temperature given in Section 13.

If there is a risk of significant particle contamination, a suitable 1µm filter unit should be incorporated in the system before the sample gas enters the analyzer.

5 ELECTRICAL INSTALLATION

Compression couplings are supplied at the sample inlet and outlet to the katharometer panel. These couplings are suitable for connecting 8mm outside diameter metal tube. It is recommended that stainless steel tube is used.

5.1 Electrical Interconnections



Warning.

- Equipment in this system operates on a.c. mains supply voltage electricity. Suitable safety precautions must be taken to avoid the possibility of electric shock.
- Although certain instruments are fitted with internal fuse protection, a suitably rated external protection device, e.g. a 3A fuse or miniature circuit breaker (m.c.b.), must also be fitted by the installer.
- The proper electrical connections and wiring standards must be achieved to establish the intrinsic safety of the

system, as certified.

- The a.c. input and intrinsically safe d.c. output wiring must be routed separately from non-intrinsically safe wiring.

Fig. 5.1 shows the interconnecting wiring requirements which must be strictly observed. Details of cable requirements, which must be strictly adhered to, are also given in Section 5.2.1.

After completing the wiring, check that the continuity grounding and isolation of all circuits is to the required local electrical standards for intrinsically safe circuits.

The separate units of the system must be interconnected as follows:

5.1.1 Model 4689 503 Display Unit – Fig. 5.2

- 1) Remove the rear cover of the unit to gain access to the terminal blocks.

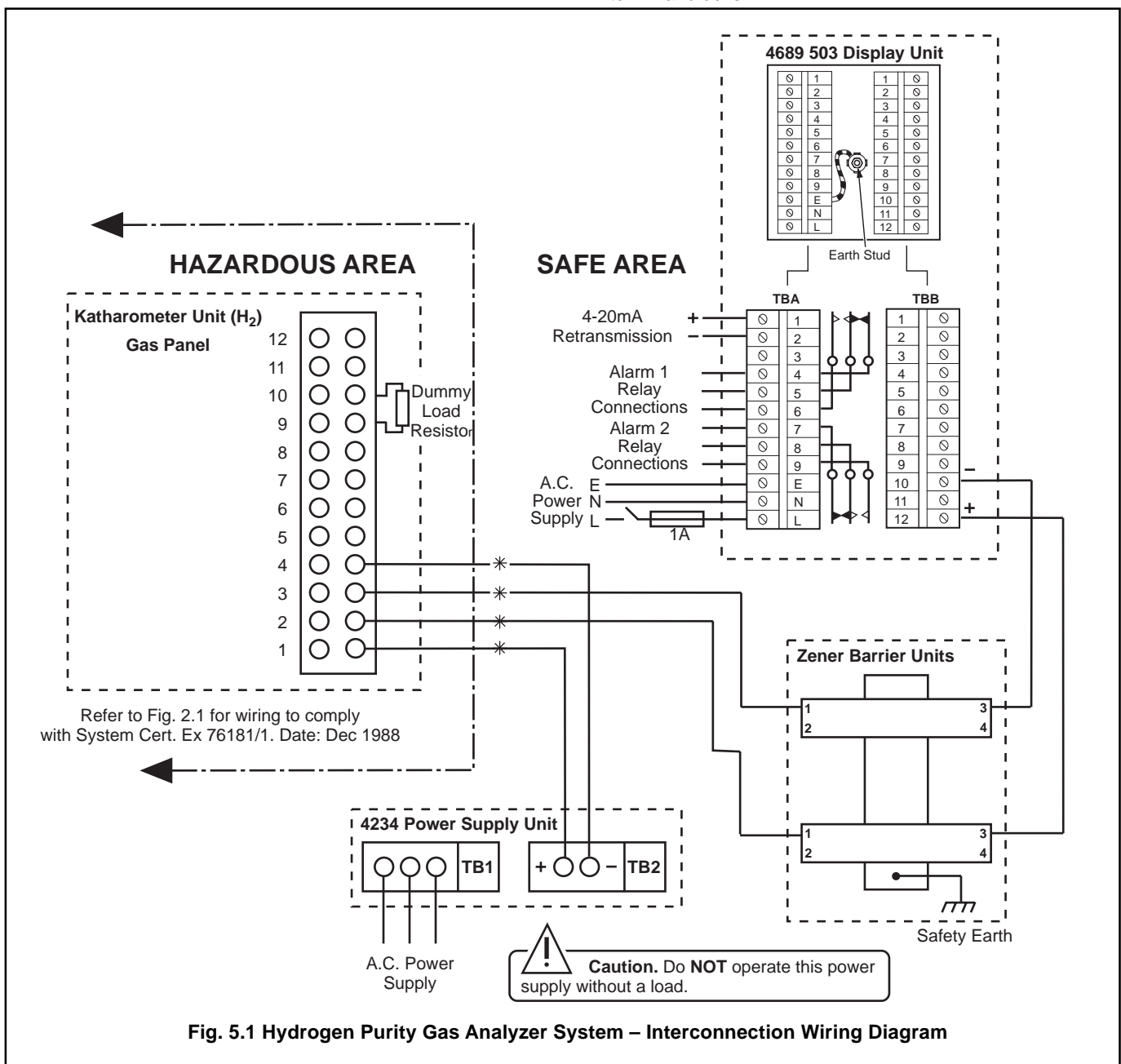

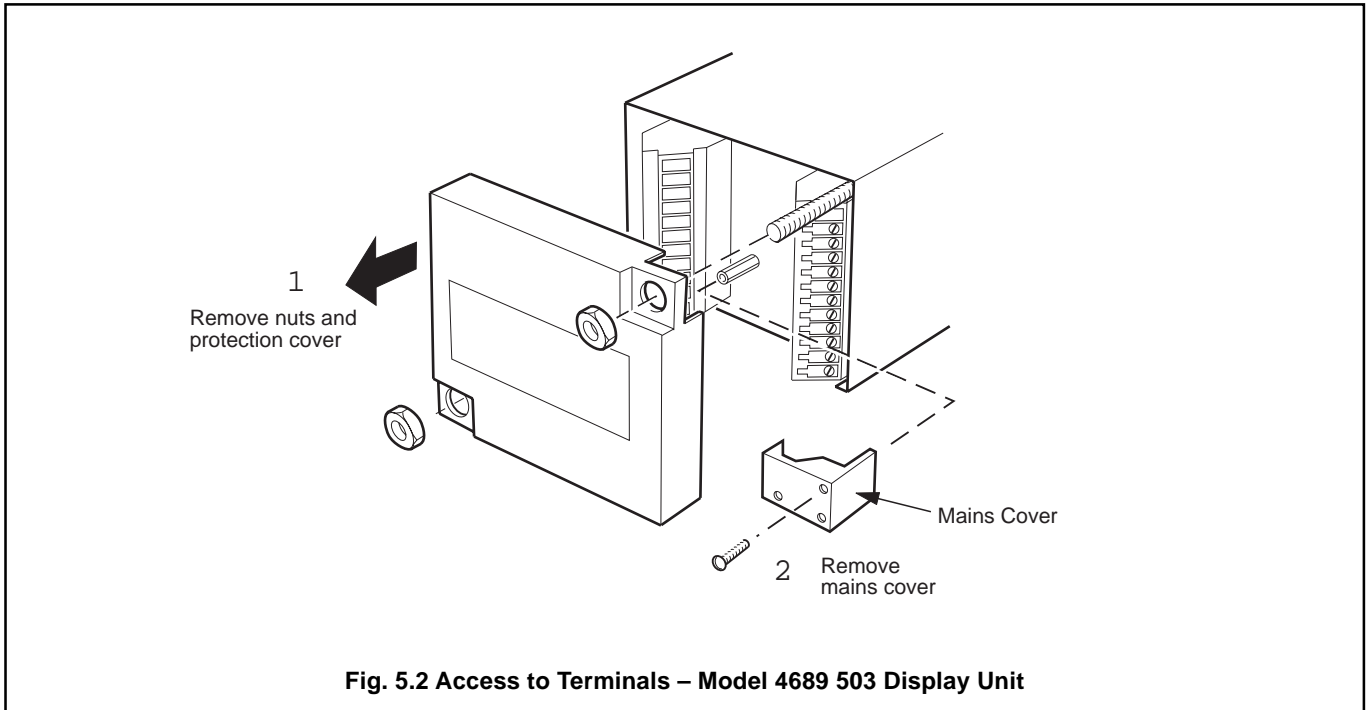

2) Make the wiring connections in accordance with the information given in the wiring diagram Fig. 5.1 and Section 5.

5.1.2 Model 6540 203 Katharometer Analyzer Panel – Fig. 5.3

All the electrical connections are made inside the katharometer unit (6539 960) on the analyzer panel.

1) Remove the cover of the katharometer unit to gain access to the terminal block (TB1) inside.

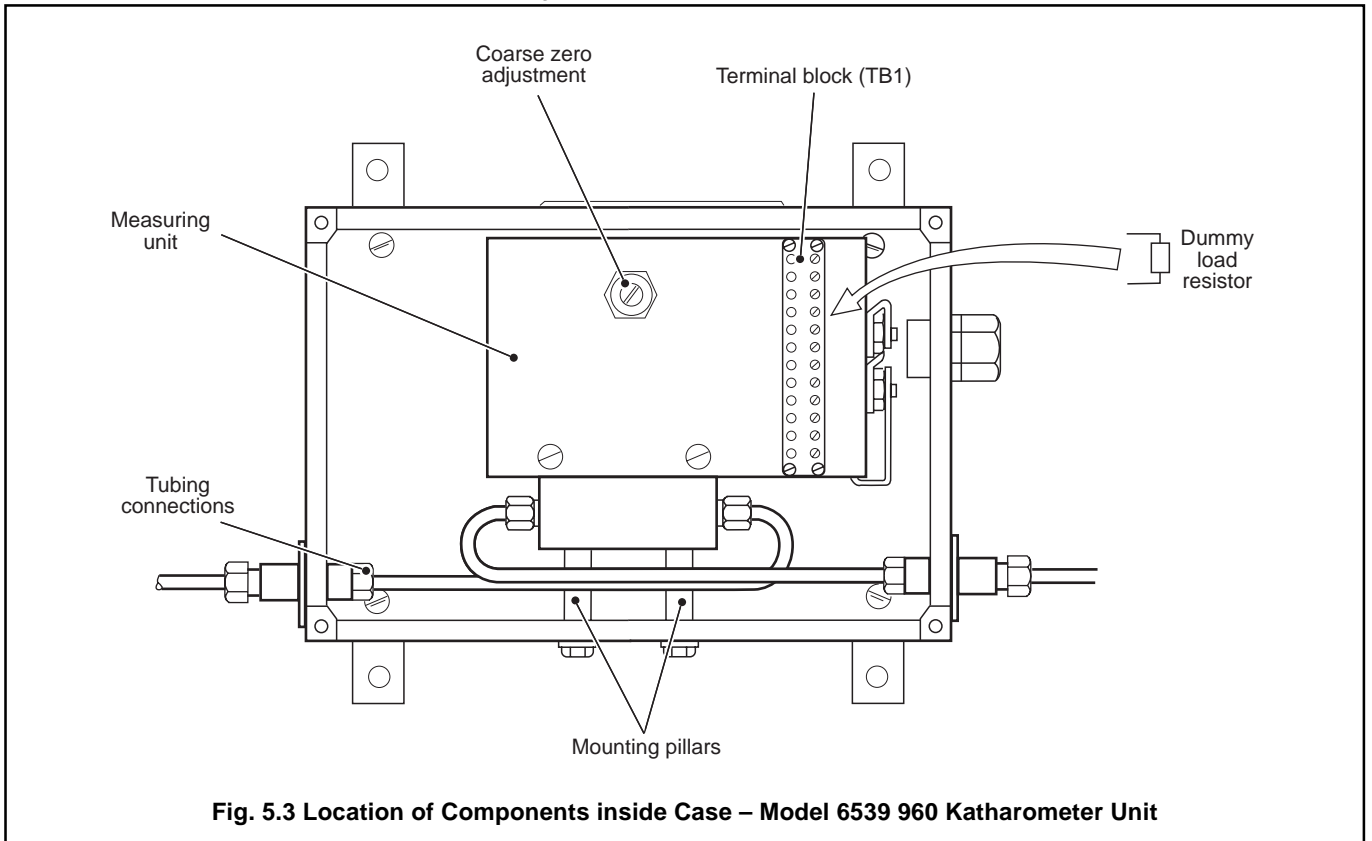

..5 ELECTRICAL INSTALLATION

- 2) Make the electrical connections in accordance with the information given in wiring diagram Fig. 5.1 and Section 5.2.1.

*** Note.** The electrical connections are made at the terminal block (TB1) via the cable gland, or any replacement gland to suit the intrinsically safe wiring requirements.

- 1) Remove the 510R dummy load resistor from across terminals 9 and 10, when the appropriate interconnections have been made.

- 2) Replace the cover of the katharometer unit on completion of wiring up.

5.1.3 Model 4234 Power Supply Unit – Fig. 5.4

Warning. Do not connect mains supply to the power supply unit with the output terminals open circuit. This causes premature component failure.

Caution. Ensure that the power supply unit is correct for the mains supply voltage available. A nominal 110V unit cannot be adapted for use with a nominal 240V supply, or the other way around.

- 1) Remove the cover of the unit to gain access to the terminal blocks inside.

- 2) Locate the terminal block (TB3) adjacent to the transformer T1. If necessary, adjust the transformer tapping to the correct incoming supply 110/120V, 200/220V or 240V by moving the brown wire to the appropriately marked terminal of TB3.

- 3) Make electrical connections in accordance with the information given in the wiring diagram Fig. 5.1 and Section 5.2.1.

*** Note.** The electrical connections are made at terminal blocks TB1 and TB2 through the appropriate cable gland, or any replacement gland to suit intrinsically safe wiring requirements.

- 4) Secure the incoming cable by the cable clips adjacent to the terminal blocks.

- 5) Fit the cover on completion of wiring up.

5.2 Intrinsically Safe Requirements

These requirements relate to the interconnecting wiring made to and from the Model 6540 203 Katharometer Analyzer Panel in the hazardous area, and those for remote ancillary items connected to the system.

5.2.1 Cable Requirements

The interconnecting cables between the various units of the system are subject to stringent limitations because of the requirements of the intrinsic safety certification. These follow

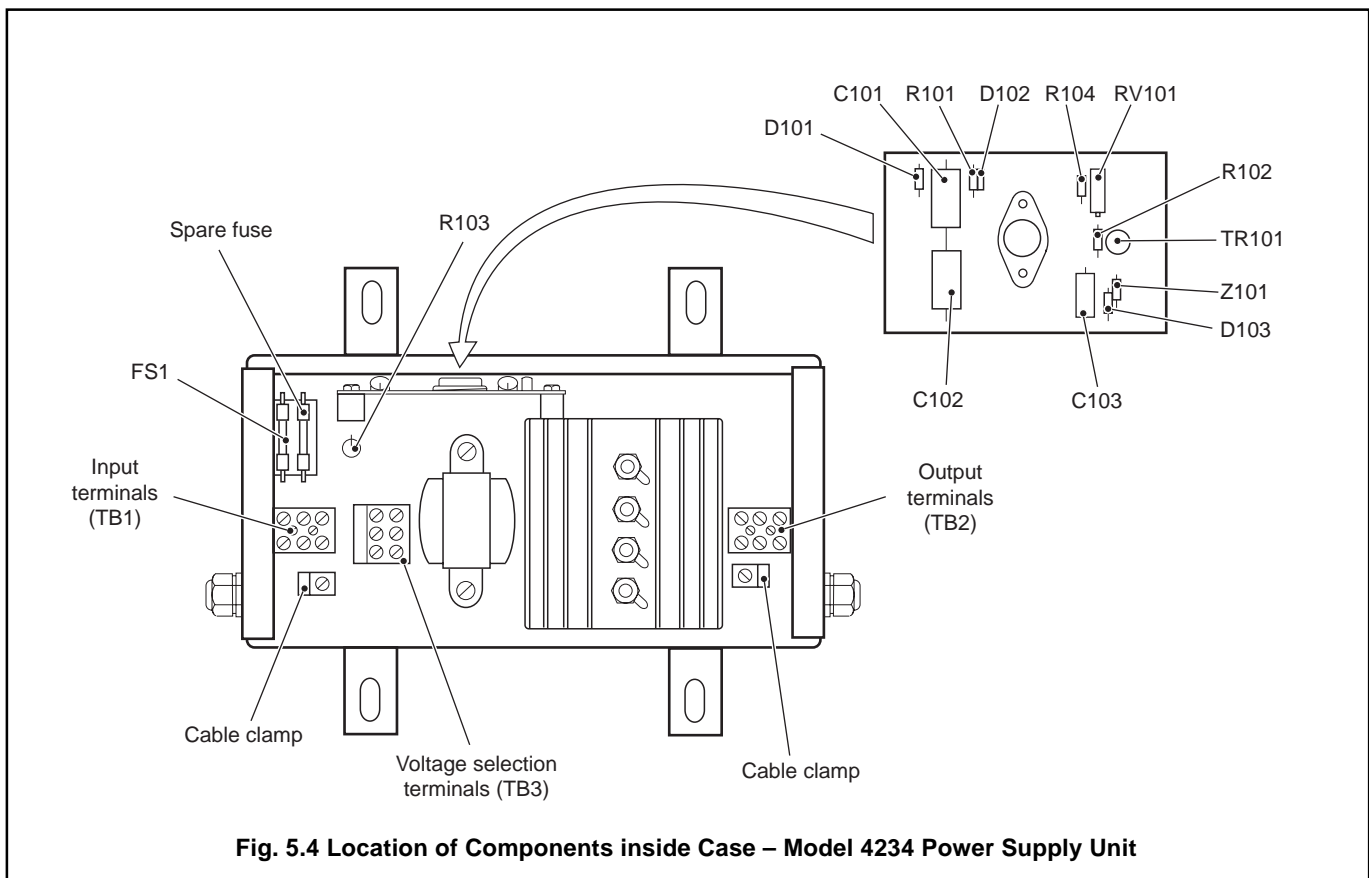
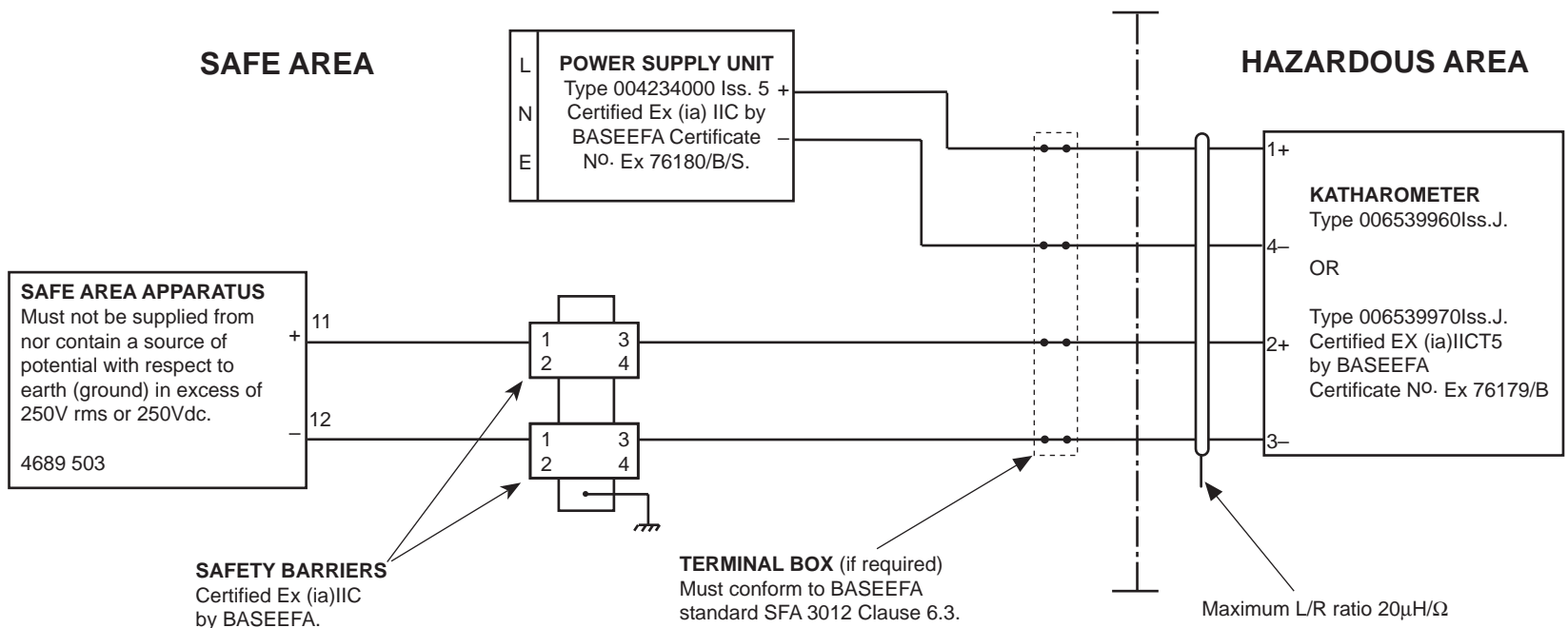

Fig. 5.4 Location of Components inside Case – Model 4234 Power Supply Unit



Notes

- 1 The total capacitance and inductance or inductance to resistance ration L/R of the cables which connect the output from the power supply together with the barrier outputs (Hazardous Area Terminals) to the katharometer input/output terminals must not exceed the following values:

Table 1

Group	Capacitance in μF	Inductance OR L/R ratio in μH/Ω	
IIA	24.0	0.200	160
IIB	9.0	0.075	60
IIC	3.0	0.025	20

- 2 The installation must conform to the BASEEFA Installation Conditions Issue 6, Dated 1st September 1976.

SYSTEM VARIATION FOR THE USE OF ALTERNATIVE BARRIERS

One katharometer plus power supply system with signal return via barriers are shown. The restrictions on the safe side of the barriers are such that no apparatus may be connected that is supplied from greater than 250V rms with respect to earth. The safety barriers used to protect the measuring system must provide two channels or one channel plus one earthed return.

The barriers must be of like polarity and not exceed 5V or 0.44A or 0.44W (matched power), e.g. MTL103, MTL105, MTL755. Table 1 cable parameter values for capacitance and inductance or L/R ration must not be exceeded.

OR

The barriers must be of like polarity and not exceed 15V or 0.8A or 0.3W (matched power), e.g. MTL164, MTL764. Table 1 cable parameter values for capacitance must be reduced by a factor of four and not exceeded; inductance and L/R ratio figures are unaffected.

Fig. 5.5 System Diagram. System Certificate Ex76181/1 dated Dec 1988

...5 ELECTRICAL INSTALLATION

and are also detailed in Fig. 5.5.

All cables entering the **hazardous area**, **MUST** be kept separate from cables in the **safe area**. Cables entering the **hazardous area**, **MUST NOT** be run with other cables, and terminations must have a grounded screen to separate them from connections for other circuits.

The detailed requirements are as follows:

1) **Connections between Model 6540 203 Katharometer Analyzer Panel and Model 4234 Power Supply Unit.**

All cables from the Katharometer into the hazardous area must have an inductance/resistance ratio not exceeding $18\mu\text{H}/\Omega$, (for Group IIC gases). There is a further requirement that the maximum resistance of this interconnecting cable is limited to 2Ω . This may place a limitation on the length of the total cable run. Single sheathed conducting cables should be twisted together to reduce their mutual inductance, and routed separately from cabling for non-intrinsically safe circuits in the safe area.

2) **Connections between Model 6540 203 Katharometer Analyzer Panel, Zener Barrier Unit and Model 4689 503 Display Unit.**

No special requirements are necessary to limit the choice of cable for the interconnection between the katharometer zero adjustment controls and the display unit.

5.2.2 Recommended Cables

The limitations imposed restrict the choice of wiring cable to a few types. 'Pyrotex' meet the requirements of less than $18\mu\text{H}/\Omega$ with their mineral insulated cable type PCC 2L1.

Kent-Taylor should be consulted with information on any other cables proposed for use in the installation of this system.

Detailed cable specifications of the above mentioned type is

available from:

Pyrotex Limited
Hedgeley Road
Hebburn-on-Tyne
County Durham
Telephone: 091 483 4123

5.2.3 Full Intrinsically Safe Requirements

For systems to be modified or used with other gases the full BASEEFA requirements must be complied with as follows:

- 1) The total Capacitance and Inductance or Inductance to Resistance ratio (L/R) of the cables connecting the katharometer unit to the display unit and power supply unit terminals (TB1), must not exceed the values given in Table 5.1.

Table 5.1 6553 – Intrinsically Safe Wiring Requirements

2) Any terminal boxes used in the hazardous or safe areas must conform to BASEEFA Standard EN 60072, clause 6.3.

3) The overall installation must conform to the BASEEFA installation conditions, Issue 6 (September 1976) – see Fig 1A

Gas Group	Capacitance μF	Inductance mH	Inductance/ Resistance $\mu\text{H}/\Omega$
IIB	4.8	0.152	144
5.5	1.8	0.057	54
IIC	0.6	0.019	18

When the gas analyzer system has been correctly installed in accordance with the requirements for intrinsic safety given in Section 5.2, carry out the following setting-up procedures:

6.1 Katharometer Analyzer Panel- Filling the Drying Chamber – Fig. 6.1

- 1) Remove the drying chamber on the katharometer analyzer panel by unscrewing the large knurled nut at the base of the chamber. Pull the chamber down and out of the sealing groove to remove it from the panel.
- 2) Open a container of fresh granular calcium chloride, immediately fill, and prepare to replace the drying chamber.



Note. The capacity of the drying chamber is about 140ml. To fill the chamber, approximately 100g of calcium chloride is required.

- 3) Replace the drying chamber in its sealing groove and reposition the chamber to enable it to be secured and sealed by hand tightening the knurled nut.
- 4) Carry out an approved leak testing procedure before passing sample gas through the system.

6.2 Setting Sample Flow

When all tubing interconnections have been made and external parts of the sample system checked for leaks, the suggested procedure is as follows:

- 1) Arrange to supply calibration quality carbon dioxide gas through the gas analyzer system at the normal working pressure of the application plant and within the limits given in Section 13.
- 2) Gradually open the metering valve on the katharometer panel to pressurize the complete system to the maximum pressure given in Section 13.



Caution. Testing for leaks with carbon dioxide may not be considered an adequate check of gas tight integrity in respect of the more penetrating hydrogen gas. Consideration may be given to the use of a gas, such as helium, which has penetrating properties nearer to that of hydrogen.

- 3) Slowly open the metering valve to give a nominal flowrate of gas of 100 to 150 mlmin⁻¹. Do not exceed the maximum flowrate given in Section 13.
- 4) Set the flowrate and shut off the calibration gas external to the analyzer system.

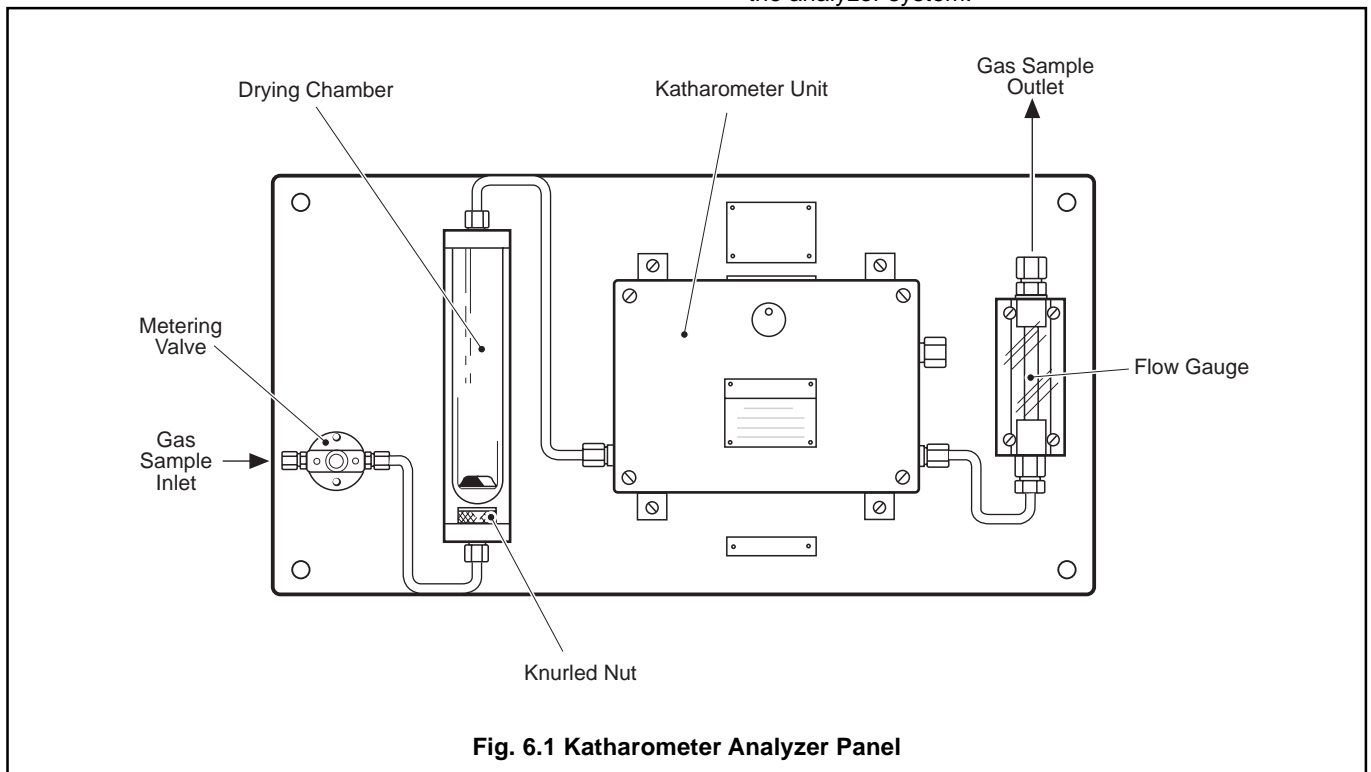

Fig. 6.1 Katharometer Analyzer Panel

...6 SETTING UP

6.3 Electrical Checks

6.3.1 Model 4234 Power Supply Unit Output



Warning. This unit is part of the certified intrinsically safe system. Appropriate safety precautions **MUST** be taken to prevent any incendive electrical discharges in the hazardous area when carrying out this task.



Caution. Testing the output may only be carried out with the hazardous area cable disconnected and a dummy load resistor fitted across the output. **NEVER OPERATE THE UNIT TO SUPPLY AN OPEN CIRCUIT.**

- 1) Electrically isolate the power supply unit.
- 2) Remove the cover from the power supply unit.
- 3) Disconnect the output wires to the hazardous area at terminals TB2 '+' and TB2 '-'.
- 4) Connect a 10Ω (2W ±5%) dummy load resistor across terminals TB2 '+' and TB2 '-'.



Warning. Ensure that proper electrical safety precautions are taken at all times whilst undertaking this procedure.

- 5) Switch on the power supply unit and check that it is stable at 350mA.
- 6) On completion of tests isolate the unit, remove the dummy load resistor and reconnect the output wires to the hazardous area.
- 7) Replace the cover on the unit.

6.3.2 Zener Barrier Units – Fig. 6.2

The zener barriers units are checked at the time of manufacture. To ensure absolute safety on a new installation, check that the barriers are properly earthed by carrying out a routine test before using the analyzer system.



Warning. This unit is part of the certified intrinsically safe system. Appropriate safety precautions must be taken to prevent any incendive electrical discharges in the hazardous area when carrying out this

task.

If these tests reveal a faulty zener barrier, the barrier must be replaced by a new unit.



Note. The barrier is a sealed unit and no repair is permitted. The correct zener barriers are certified intrinsically safe to EX (ia) IIC and no other type may be substituted.

- 1) Electrically isolate the barrier.
- 2) Disconnect the cable connected to terminal 3 of the barrier unit – see Fig. 6.2.
- 3) Using a low voltage ohmmeter, measure the resistance between terminals 1 and 3. This must be less than 18.15Ω. If in excess of this value – change the barrier.
- 4) Using a low voltage ohmmeter, ensure that the resistance between terminals 2 and 4 of the barrier unit and the application plant safety earth is less than 1Ω.
- 5) Connect the wire to terminal 3 on the barrier unit.

6.3.3 Checking System Earth

Check that the resistance between earth terminals on the analyzer system and the application plant system safety earth does not exceed 1Ω.

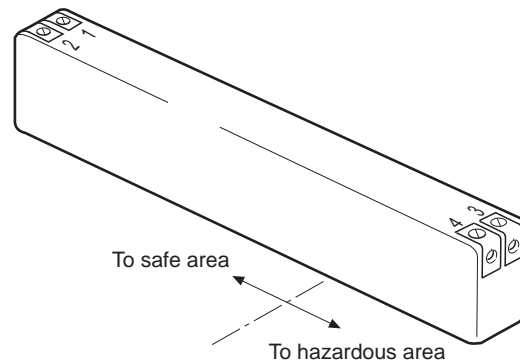

Fig. 6.2 Zener Barrier Units in the 6553 Monitor Unit

7.1 Displays – Fig. 7.1.

The upper display line shows actual values of hydrogen purity, alarm set points or programmable parameters. The lower display line shows the associated units or programming information.

7.2 Switch Familiarization – Fig. 7.1 and 7.2

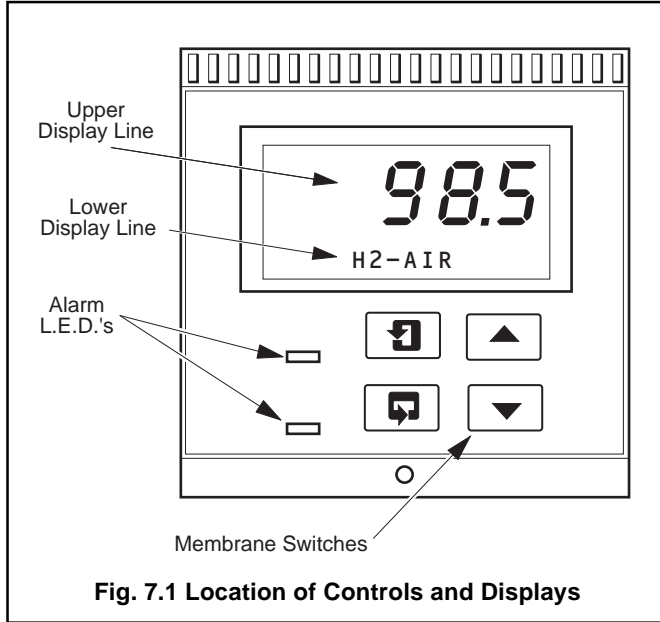
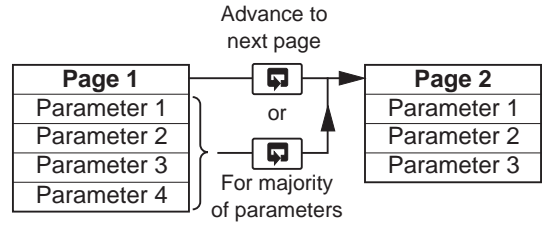
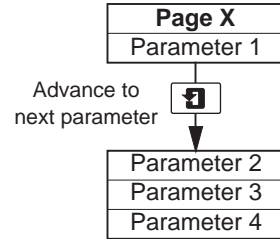

Fig. 7.1 Location of Controls and Displays



A – Advancing to Next Page



B – Moving Between Parameters

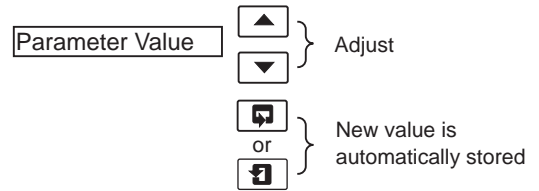

C – Adjusting and Storing a Parameter Value

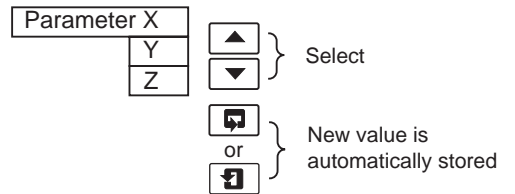

D – Selecting and Storing a Parameter Choice

Fig. 7.2 Function of the Membrane Switches

8 START-UP



Warning. When the apparatus is connected to its supply, terminals may be live, and the opening of covers or removal of parts (except those to which access may be gained by hand) is likely to expose live parts.

8.1 Instrument Start-up

In normal operation the instrument displays the **Operating Page** which is a general use page in which parameters are viewed only and cannot be altered. Any changes to the operating parameters are implemented using the switches as described in Section 7.2. To alter or program a parameter refer to Section 10. A 5-digit Security Code is used to prevent unauthorised access to programmable parameters. The value is preset at 00000 to allow access during commissioning but should be altered to a unique value, known only to authorized operators, as described in Section 10.4.

When all the required wiring connections and electrical checks have been correctly made, the power supplies to the various units may be switched on as follows:

- 1) Switch on the supply voltage to the Power Supply Unit.
- 2) Switch on the supply voltage to the Display Unit.

8.2 Alarm Set Points

8.2.1 Type of Alarm Action

The alarm relay coil is energized during normal non-alarm relay states and is de-energized upon recognition of an alarm condition, thereby providing 'fail-safe' alarms. i.e. with Alarm 1 set point = 95.0, when the display is indicating greater than 95.0 (plus hysteresis), then Alarm Relay 1 is energized and Alarm 1 LED is OFF. When the display indicates less than 95.0 (minus hysteresis), then Alarm Relay 1 is de-energized and Alarm 1 LED is ON. This operating mode ensures that, in the event of a mains power failure, an alarm condition is signalled.

8.2.2 Hydrogen

It is suggested that the hydrogen alarm set-points should be based on a reducing percentage of hydrogen as it is displaced by air entering the application plant. This can be achieved by setting Alarm 1 and Alarm 2 to give ample warning of the development of a potentially explosive mixture. Factory settings are: Alarm 1 = 95.0 and Alarm 2 = 90.0.

- 1) Access the programming pages and input the alarm set-

points in accordance with the information given in Section 10.2.

8.3 Calibration

Before putting the system on-line, carry out a calibration check on the zero input signal using calibration sample gas. The maximum input signal for the full range reading is preset during manufacture and sealed.



Caution. These sealed adjustments must **NOT** be altered by users.



Note. The 4600 Series instruments incorporate a two point calibration sequence requiring both zero and span inputs for a calibration. It is not possible to adjust either the range zero or the range span scale points independently.

The local coarse 'zero' adjusters at the katharometer units in the hazardous area are redundant when this adjustment is transferred to the gas monitor unit. The potentiometers in the katharometer units should be set to the midpoint on installation and sealed off. A summary of the system functions and calibration data is given in Table 8.1.

8.3.1 Hydrogen



Warning. Test for leaks in accordance with the requirements of the responsible authority after making any hydrogen connections.

- 1) Arrange to pass calibration quality Hydrogen gas through the Katharometer Unit at the normal working pressure of the sample gas system. This should give the correct flowrate of gas, as set previously.
- 2) Power up the display unit, and switch on the power supply unit to power up the katharometer unit.
- 3) The display unit will indicate the measurement parameter - percentage by volume of hydrogen in air (H₂ - AIR). The upper display line will indicate a value for the parameter.
- 4) With hydrogen calibration gas passing through the sample system at the normal flowrate, the upper display line of the display unit should stabilize within 2 hours to read 100.0 .

- 5) If necessary, refer to Section 10.3 for a full calibration sequence.



Note. A coarse zero adjustment facility is available

Table 8.1 System functions and Calibration Settings

Function	No mV output at Katharometer		10 mV output at Katharometer	
	Calibration Gas	Calibration Setting	Calibration Gas	Calibration Setting ‡
% H ₂ in AIR	100% H ₂	100.0	-	80%* or 85%

* – As specified for application

‡ – Not user adjustable

at the top 'zero' potentiometer. Adjustment is made by inserting a screwdriver through the hole behind the small escutcheon plate.

9.1 Normal

During normal operation the Gas Analyzer System is used to indicate the purity of hydrogen used as a coolant. The display unit shows the percentage of hydrogen in air, which should be safely in excess of the explosive limit at the hydrogen rich end.

There are no routine adjustments required to the gas analyzer system after completion of start-up procedures and putting on-line in monitoring mode. The system only requires minor adjustments to the metering valve to maintain the required flowrate and the carrying out of safety routines.

9.2 Purging of Hydrogen Coolant Gas

When the hydrogen coolant has to be removed from the application plant, it is wasteful and dangerous to release the coolant gas directly into the atmosphere. It is therefore necessary to ensure that the system is outside the explosive limits for air-in-hydrogen before allowing air into the system.

Initially, inert purge gas (carbon dioxide) is introduced into the system. When the hydrogen concentration is safely below the explosive limit, air is introduced into the system to completely displace the other two gases.

A Model 6553 Gas Analyzer System is available which provides all the necessary indications and output signals to enable this operation to be carried out safely.

9.3 Filling with Hydrogen Coolant Gas

This procedure is a reversal of the purging procedure.

Initially, inert purge gas (carbon dioxide) is introduced into the application plant until the air content is safely below the explosive limit for air in hydrogen. When this limit is reached, hydrogen is gradually introduced into the system to displace

the other two gases.

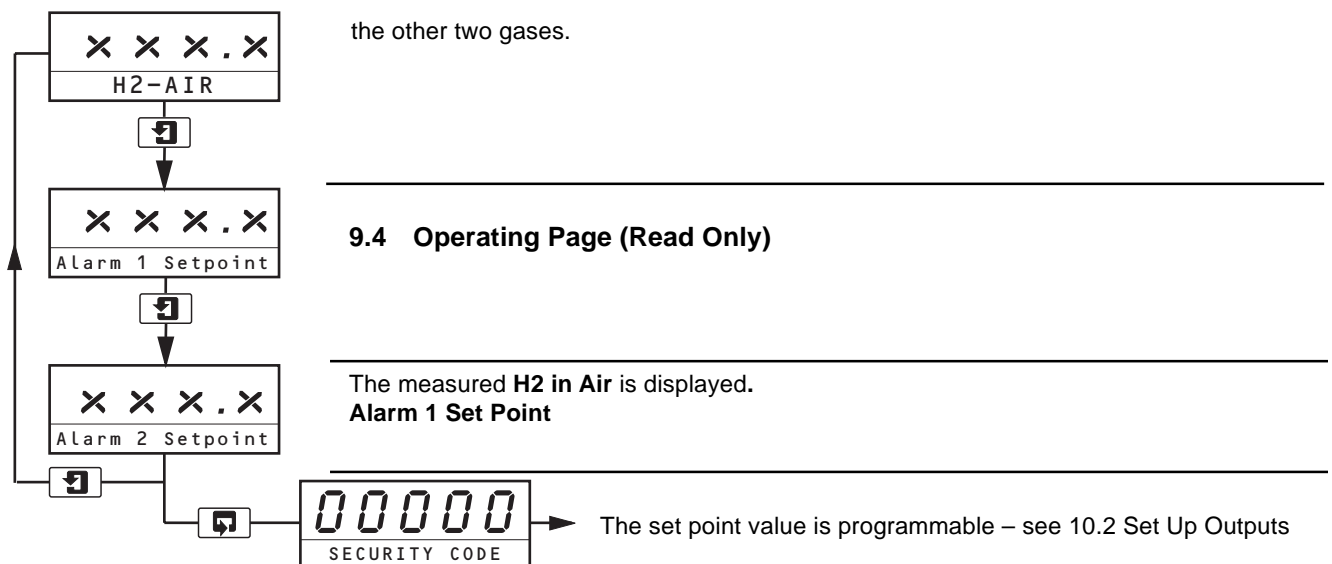

10 PROGRAMMING

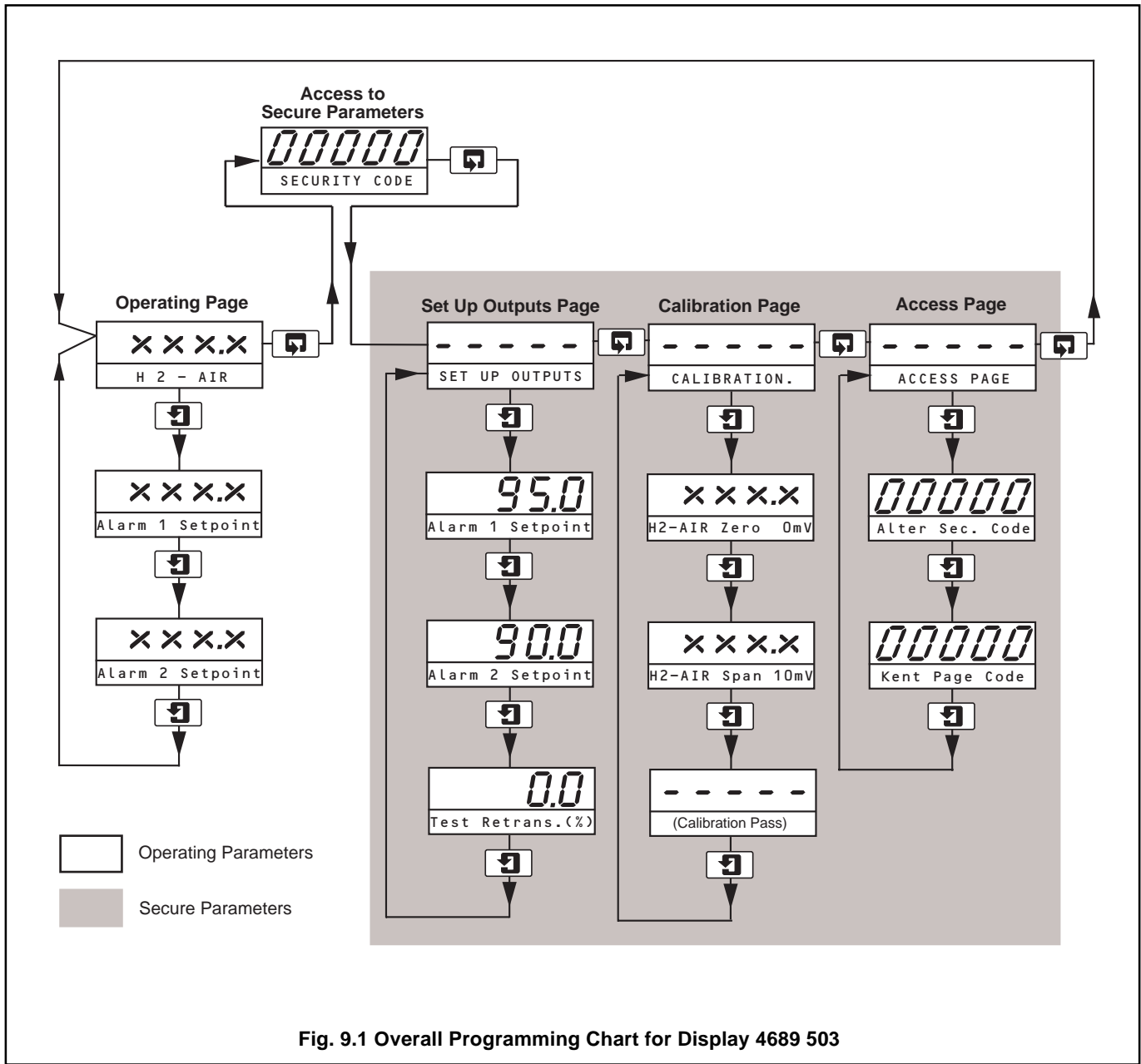

Fig. 9.1 Overall Programming Chart for Display 4689 503

Page.
Alarm 2 Set Point



The set point value is programmable – see 10.2 Set Up Outputs Page. Advance to Security Code Page.

10.1 Access to Secure Parameters

A 5-digit code is used to prevent tampering with the secure parameters.

Security Code

Enter the required code number, between 00000 and 19999, to gain access to the secure parameters. If an incorrect value is entered, access to subsequent programming pages is prevented and the display reverts to the **Operating page**.

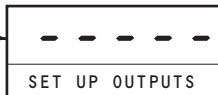

Note. The security code is preset at '00000' to allow access during commissioning but should be altered to a unique value, known only to authorized operators – see 10.4 Access Page.

Advance to Set Up Outputs Page.

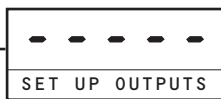

10.2 Set Up Outputs Page

Page Header – SET UP OUTPUTS

Advance to next parameter.

Alarm 1 Set Point

The set point band is defined as the actual value of the set point plus or minus the hysteresis value. The hysteresis value is $\pm 1\%$ of the full span value displayed in 10.3 Calibration Page. Alarm action occurs if the input value is above or below the set point band. If the input moves within the set point band, the last alarm action is maintained.

The Alarm 1 Set Point can be set to any value within the input range being displayed. The decimal point position is set automatically. The alarm LEDs are illuminated in the alarm condition.



Alarm 2 Set Point

Set the value required. Repeat as for **Alarm 1 Set Point** above.

The decimal point position is set automatically. The alarm LEDs are illuminated in the alarm condition.



Test Retransmission Output

The instrument automatically transmits a test signal of 0, 25, 50, 75 or 100% of the retransmission range. The % test signal selected is shown on the upper line of the display.

Example – for the range of 4 to 20mA and 50% retransmission test signal,



...10 PROGRAMMING

10.3 Calibration Page

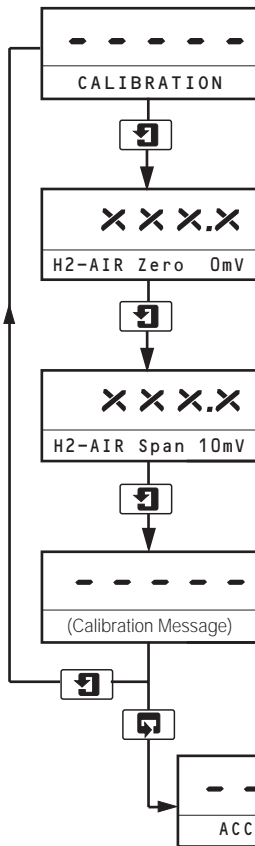

Page header – **CALIBRATION.**

Note. The 4600 Series instruments incorporate a two point calibration sequence requiring both zero and span inputs for a calibration. It is not possible to adjust either the range zero or the range span scale points independently.

Calibration Range Zero, H2-AIR

Proceed as described in Section 8.3 Calibration, but apply a signal input equivalent to range zero (0.0mV). Allow the instrument display to stabilise.

Advance to next parameter.

Calibration Range Span, H2-AIR

Proceed as for Calibration Range Zero H2-AIR above, but apply a signal input equivalent to range span (10.0mV). Allow the instrument display to stabilise.

Advance to next parameter

Calibration Message

Refer to Table 10.1 for calibration message clarification.

10.4 Access Page

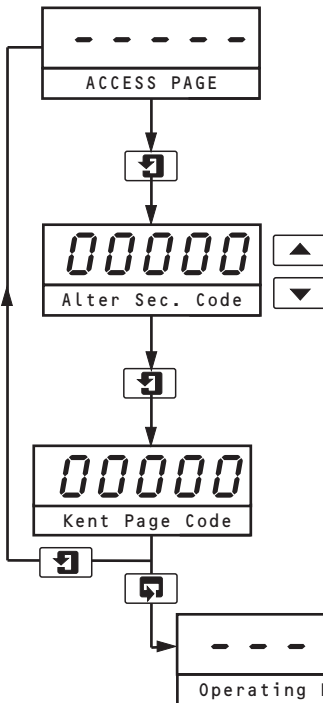

Page Header – **ACCESS PAGE.**

Advance to next parameter

Alter security Code

Set the security code to a value between 00000 and 19999.

Advance to next parameter

Kent Page Code

For access by ABB Kent-Taylor engineers only.

Table 10.1 Katharometer Calibration Messages for Section 10.3

Calibration Message	Explanation	Action
Calibrating...	Calibration of new calibration coefficients	None
Calibration Pass	The new calibration coefficients are used	None
H2-AIR Cal Fail	The new calibration coefficients are ignored and the last known good calibration coefficients are used.	Repeat procedure with a calibrated mV source. If the problem persists, contact the Company

11 MAINTENANCE

12mA is transmitted.

Select the required retransmission test signal.

Advance to 10.3 Calibration Page.



Warning.

- Each unit of this system forms an integral part of a certified intrinsically safe system. Appropriate safety precautions must be taken to prevent any incendive electrical discharges in the hazardous area when carrying out these tasks.
- Equipment in this system operates on a.c. mains supply voltage electricity. Suitable precautions must be taken to avoid the possibility of electric shock.
- The maximum pressure and temperature specified for particular parts of the system must not be exceeded.

The units are designed for stable and accurate operation over long periods.

This section covers the requirements for fault finding, diagnostic tests and maintenance tasks.

11.1 General Maintenance

11.1.1 Pressure

The operation of the katharometer unit is not affected significantly by changes in pressure providing it is within the pressure limits given in Section 13.

11.1.2 Flow

The katharometer zero balance and sensitivity are independent of the sample flowrate, as the sample gas sensing system depends on molecular diffusion. But the speed of response is affected by the flowrate. This means that the flow resistance of the drying chamber is a compromise between obtaining speed of response, and avoiding a rapid degradation of the desiccant.

11.1.3 Leaks

There is an inherent safety requirement that there are no leaks into or out of the sample system. Any leaks could also affect the correct operation of the katharometer unit.

11.1.4 Vibration

The katharometer unit tolerates reasonable levels of mechanically induced vibration. Pulsations due to unsteady sample flow can affect the katharometer filaments and cause errors due to excessive cooling.

11.1.5 Contamination

Contamination in the sample system can arise from oil or suspended particles, or from erosion of material from the sample system upstream of the katharometer unit.

11.1.6 Ambient Temperature

The calibration of the katharometer is not significantly affected by variations of the ambient temperature. Temperature changes can

affect the sensitivity and reduce accuracy on sensitive ranges.

11.1.7 Bridge Current

The working current of the katharometer bridge is 350mA supplied from the power supply unit. This value must remain stable during normal operation as the katharometer output signal is approximately proportional to the cube of the bridge current.

11.2 Diagnostic Tests

11.2.1 Checking Output of 4234 Power Supply Unit

Carry out the test procedure given in Section 5.3.1 .

11.2.2 Checking Integrity of Zener Barrier Units

Carry out the test procedure given in Section 5.3.2.

11.2.3 Checking the Katharometer Output



Warning.

- This unit is part of the certified intrinsically safe system. Appropriate safety precautions must be taken to prevent any incendive discharges in the hazardous area when carrying out this task.
- Ensure that the proper electrical safety precautions are taken at all times whilst undertaking this procedure.

- 1) Electrically isolate the display unit
- 2) Remove the outer cover from the 6539 960 katharometer unit.
- 3) With the katharometer operating, check if the voltage across terminals TB1 - 1 and TB1 - 4 is not above 4V with 350mA passing. If the voltage is above this value it is likely that one or more filaments of the bridge is broken.
- 4) With the katharometer operating, check that the voltage across terminals TB1 - 1 and TB1 - 4 is below 2.8V with 350mA passing. If the voltage is below this value and there is no zero adjustment available, it is likely that there is an accumulation of liquid within the katharometer block.
- 5) If the reading from the test made at step 3) is unstable when the katharometer block is tapped gently, this could indicate that a filament is damaged but not open circuit.

If any of these tests indicate that the katharometer is faulty the complete katharometer unit must be returned for repair or replacement.

The sensitivity adjusters of katharometer units are sealed and must not be tampered with.

11.3 Routine Maintenance

11.3.1 Hydrogen Katharometer Calibration

Carry out a calibration procedure in accordance with Section 8.3.

This task should be carried out at intervals of 3 months of on-line use.

11.3.2 Changing Desiccant in the Drying Chamber

The need to change the desiccant in the drying chamber on the katharometer analyzer panel depends on the condition of the sample gas.

It is recommended that the analyzer system is monitored regularly during the initial phase of operation for indications that the desiccant is exhausted. Then a suitable maintenance interval for this task can be established.

As the desiccant degrades, the white grains can be seen to have a yellowish tinge and the granular form becomes more consolidated. If liquid contamination occurs the desiccant becomes brown and consolidated.

Warning. Suitable safety precautions **MUST** be taken while the gas cooling and sample systems are operational.

- 1) Isolate the sample gas system from the main system. Carry out a limited hydrogen purging operation on the sample system in accordance with the instructions of the responsible authority.
- 2) Carry out the procedure given in section 6.2.
- 3) After purging any residual air from the sample system in accordance with the requirements of the responsible authority, allow hydrogen to pass through the katharometer again.

This task should be undertaken on the basis of instrument response or at intervals of one year.

11.4 Repair Maintenance

11.4.1 Removing Liquid from the Katharometer Measurement Block – Fig. 11.1

If tests indicate that there is likely to be an accumulation of liquid in the measurement block, it may be removed using the following procedure:

- 1) Electrically isolate the defective katharometer at its power supply unit.

Caution. Do not operate the power supply with the output open circuit.

- 2) Isolate the gas sample system to the particular katharometer from the main gas cooling system. Purge the sample system of hydrogen in accordance with the requirements of the responsible authority.

Warning. The thermal insulation inside the case must not be damaged or removed.

- 3) Remove the cover of the katharometer unit and dismantle the internal sample system tubing.

- 4) Remove the fixing screws which secure the mounting pillars to the case – see Fig. 5.3.

- 5) Disconnect the interconnecting wiring at terminal block TB1.

Caution. Do not insert any type of probe into the gas system of the measurement block or use compressed air to blow through the system.

- 6) Remove the measuring unit from the case and tilt at 45° to the horizontal. This allows any liquid to drain from the measurement block – see Fig. 11.1.

- 7) Pour a small quantity of rectified spirit (ethanol) through the measurement block. Allow as much liquid as possible to drain out. Assist this by gentle shaking of the block. Repeat this procedure several times until all evidence of contamination is removed.

- 8) Fit the measuring unit into its case. Replace the fixing screws and make the electrical interconnections at terminals TB1 - 1 and TB1 - 4.

- 9) Fit the internal sample gas tubing.

- 10) Make the sample gas tube interconnection couplings.

- 11) Replace the desiccant in the drying chamber in accordance with the procedure given in Section 11.3.2.

- 12) Carry out a leak test in accordance with the requirements of the responsible authority.

- 13) Power up the katharometer unit by switching on the appropriate power supply unit.

- 14) Arrange to pass dry air or another suitable dry gas through the katharometer at the normal sample flowrate for 24

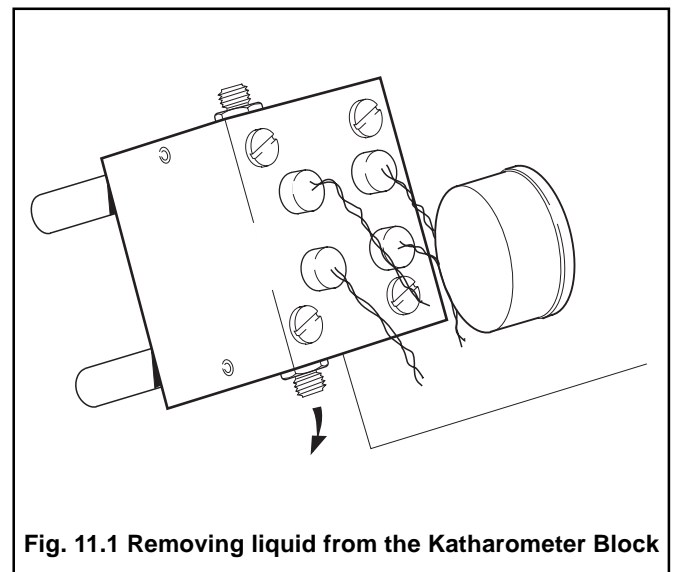

Fig. 11.1 Removing liquid from the Katharometer Block

...MAINTENANCE

hours.

- 15) Isolate the katharometer unit at its power supply unit.



Caution. Do not operate the power supply with the output open circuit.

- 16) Make the remaining electrical connections at TB1 of the katharometer unit – see Fig. 5.1.

- 17) Fit the cover of the katharometer unit.

- 18) Power up the katharometer unit from the power supply unit.

Table 11.1 Error Messages

Error Message	Explanation
NV Memory Error	The contents of the non-volatile memory has not been read correctly during power up. *

* To rectify fault, switch OFF, wait 10 seconds and switch ON again. If fault persists, contact the Company.

12 SPARE PARTS LIST

- 19) Carry out a calibration procedure in accordance with Section 8.3.

This task should be undertaken as required.



Note. It is possible that the zero reading may drift for several days after the removal of liquid.



Warning. Interference with any unit or its components implies acceptance of responsibility by that person for ensuring the continuing maintenance of intrinsic safety requirements. Unauthorized repair, spare parts or incorrect assembly may render any unit unfit for use within a hazardous area.



Note. Although the digital display unit may be marked 4600 on the display facia, it is a dedicated variant which is not interchangeable with the standard 4600 Controller/Display. This dedicated display unit is identified (4689 503) as shown in Fig. 3.1.

When ordering a 6539 960 katharometer unit, it is necessary to specify the zero gas in association with the Kent-Taylor part number. See the typical identification label shown in Fig. 3.3.

12.1 Consumables

Description	Part No.
Model 6540 203 Katharometer Analyzer Panel	
Granular anhydrous Ca Cl ₂	Locally sourced

12.2 Routine Maintenance Parts

Description	Part No.
Model 4234 Power Supply Unit	
Fuse, 500 mA/>4000A hbc cartridge	002417 005

Model 6540 203 Katharometer Analyzer Panel

Seal, top of drying chamber	002310 012
Seal, bottom of drying chamber	006519 160
Gauze, drying chamber	006525 700
Katharometer Unit, coupling seal sleeve	006525 130

12.3 Repair Maintenance Parts.

Description	Part No.
Model 4234 Power Supply Unit	
Nominal 110V unit	004234 000

(a) Model 4689 503 Display Unit

Measured Value:	5-digit x 7-segment back-lit l.c.d.
Information:	16-character, single line, dot matrix back-lit l.c.d.
Range:	85 to 100% hydrogen in air.
Accuracy (Display Unit):	±0.25% of scale span.
Linearity:	±0.2% f.s.d.
Power Supply :	
Voltage requirements:	110 to 130V or 200 to 260V ac, 50/60 Hz.
Power Consumption :	<10 VA.
Error due to power supply variations:	less than ±2% for +6%–20% variation from nominal
supply	voltage.
Insulation, mains to earth:	2kV r.m.s.
Overall Dimensions:	96 x 96 x 191mm
Panel cut-out	92 ^{+0.8} _{-0.0} mm x 92 ^{+0.8} _{-0.0} mm.
Weight :	1.5 kg.
Environmental Data :	
Operating temperature limits:	–20° to 55°C.
Storage temperature limits:	–25° to 70°C.
Operating humidity limits:	up to 95%RH non-condensing.

(b) Model 6540 203 Katharometer Analyzer Panel
Incorporating Model 6539 960 (H₂) Katharometer Unit**BASEEFA Certificate No. Ex 76179/B**

Power Supply:	350mA d.c., from 4234 PSU.
Signal Output:	0 to 10mV for each range.
Accuracy:	±2% of scale span, each range.
Dead Time:	Typically 5s.
Response Time:	Typically 40s for 90% step change at katharometer.
Tubing	and drying chamber introduce extra
delays.	
Ambient Temperature:	Maximum of 50°C.
Sample Connections:	Compression couplings, 8mm outside dia. tube.
Sample Pressure:	Minimum, 125mm H ₂ O Maximum, 0.35b (G)
Normal Sample Flowrate:	100 to 150mlmin ⁻¹
Maximum Gas Flowrate:	250mlmin ⁻¹
Minimum Gas Flowrate:	50mlmin ⁻¹
Outline Dimensions:	610 x 305 x 152mm
Weight:	8.6kg approximately.

...13 SPECIFICATION

Environment:
(c) Model 4234 Power Supply Unit

Sheltered interior.
BASEEFA Certificate No. Ex. 76180/B/S

Input Voltage:	110/120V or 200/220/240V a.c., 50/60 Hz (2 separate versions)
Fuse Rating:	500mA hbc (high breaking capacity $\geq 4000A$)
dc Output:	350mA stabilised
Load Conditions:	1 katharometer – 13Ω max. Interconnecting cable – 2Ω max.
Ambient Temperature Range:	– 5 to $+50^{\circ}C$
Supply Variations:	$\pm 6\%$ (V) $\pm 4\%$ (Hz)
Regulation:	Within $\pm 0.8\%$ for: (i) Load var. of $\pm 15\%$ (ii) Supply var. of $\pm 6\%$ (iii) Ambient temp. var. of $\pm 10^{\circ}C$
Ripple:	Less than 1mA rms
Stability: temperature	Within $\pm 0.7\%$ of initial setting, over period of 1 month with load resistance, supply voltage and ambient at nominal stated values
Outline Dimensions:	148 x 283 x 135mm
Weight:	3.8kg approximately.

Environment:
Sheltered interior

A1.1 Model 4234 Power Supply Unit

Two different power supply units are available to suit different supply voltages. See **Spare Parts List**.

A1.1.1 Functional Description

A circuit diagram for each type is shown in Fig. A1 (240V), Fig. A2 (110V).

A stable supply voltage is produced across zener diodes Z3 and Z4 by utilizing the forward slope resistance of zener diodes Z1 and Z2 in the full-wave rectifier bridge connected to the secondary winding of transformer T1. A reference voltage is produced across C103 by zener diode Z101 in conjunction with R101, with diode D103 providing temperature compensation. This reference voltage is applied to the base of TR101, which is used to drive the power transistor TR102 to produce a constant current output of 350mA. The small preset potentiometer RV101 is used to provide a fine adjustment for the current output.

The output current is restricted by invariable resistors which ensure that the requirements of the intrinsic safety certification are met, even under a '2-fault' condition.



Warning. This unit is part of the certified intrinsically safe system, Appropriate safety precautions must be taken to prevent any incendive electrical discharges in the hazardous area when carrying out maintenance tasks.

A1.1.2 Fault Finding



Caution. Do not operate this unit without an electrical load on the output.

If testing indicates that this unit is defective, further fault finding may be carried out based on the typical test point values given in Table A1. There are several test points available on the unit. Reference should be made to Figs. A1, A2 and the markings Table A1 Test Point Values - Model 4234 Power Supply Unit

Test Point	Voltage V	Form	Conditions
TP1	9.1	d.c.	With respect to 0V
TP2	3.5	d.c.	With respect to 0V
TP3	3.0	d.c.	With respect to 0V
TP4	2.4	d.c.	With respect to 0V
TP5	5.0	d.c.	With respect to 0V using 10Ω dummy load
TP6	1.7	d.c.	With respect to 0V
T1	9.1	a.c.	At secondary

on the circuit boards for the location of test points and components.



Note. The primary winding of the transformer T1 incorporates a thermal cutout device to prevent overloading under fault conditions. Sufficient time must be allowed for this to cool and reset after a fault has occurred, and before continuing further testing.

A1.1.3 Parts List

Repair Maintenance Parts

Description	Part No.
Resistor	
R101, 910R, ±2%, 0.5W, metal oxide	-
R102, 3k3, ±2%. 0.5W, metal oxide	-
R103, 4R7, ±1%, 9W, wirewound	-
R104, 100R, ±2%, 0.5W, metal oxide	-
Variable resistor	
RV 101, 1k0, Spectrol Reliance, CW51	-
Capacitor	
C101, 1000µF, 16V, elect., Mullard 0175 15102	-
C102, 1000µF, 16V, elect., Mullard 0175 15102	-
C103, 100µF, 16V, elect., Mullard 0165 14101	-
Transistor	
TR101, BC 108, Mullard	-
TR 102, 2N 3766, Motorola	-
Diode	
D101, BYX 36 - 600, Mullard	-
D102, BYX 36 - 600, Mullard	-
D103, AAZ - 15, Mullard	-
Zener diode	
Z1, BZY93C9V1, Mullard	-
Z2, BZY93C9V1, Mullard	-
Z3, BZY93C9V1, Mullard	-
Z4, BZY93C9V1, Mullard	-
Z101, BZY88C3V3, Mullard	-
Fuse	
FS1, 500mA, hbc cartridge, Belling Lee L693	-
Transformer	
T1, 110 - 120V primary	4234 130
T1, 200 - 220 - 240V primary	4234 140

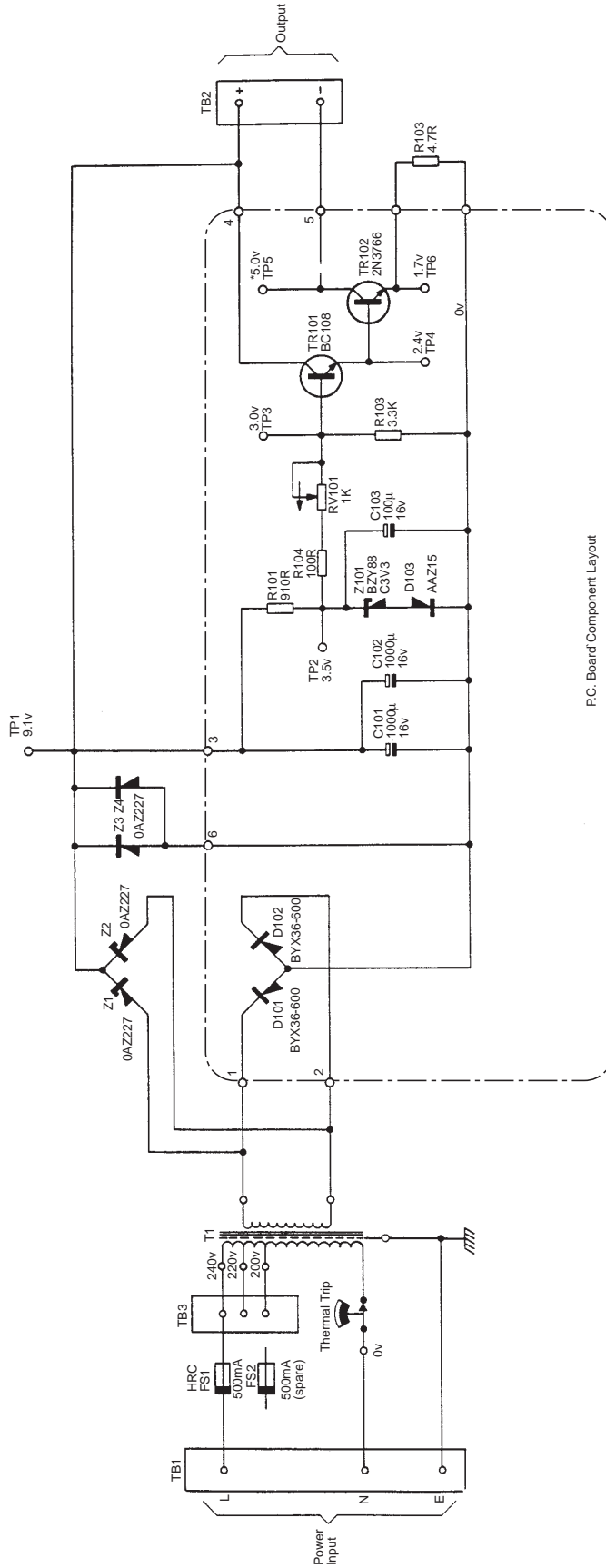

P.C. Board Component Layout

* Measured with a 10R load

Fig. A1 Power Supply Unit Model 4234 – Overall Circuit (200/220/240V Version)

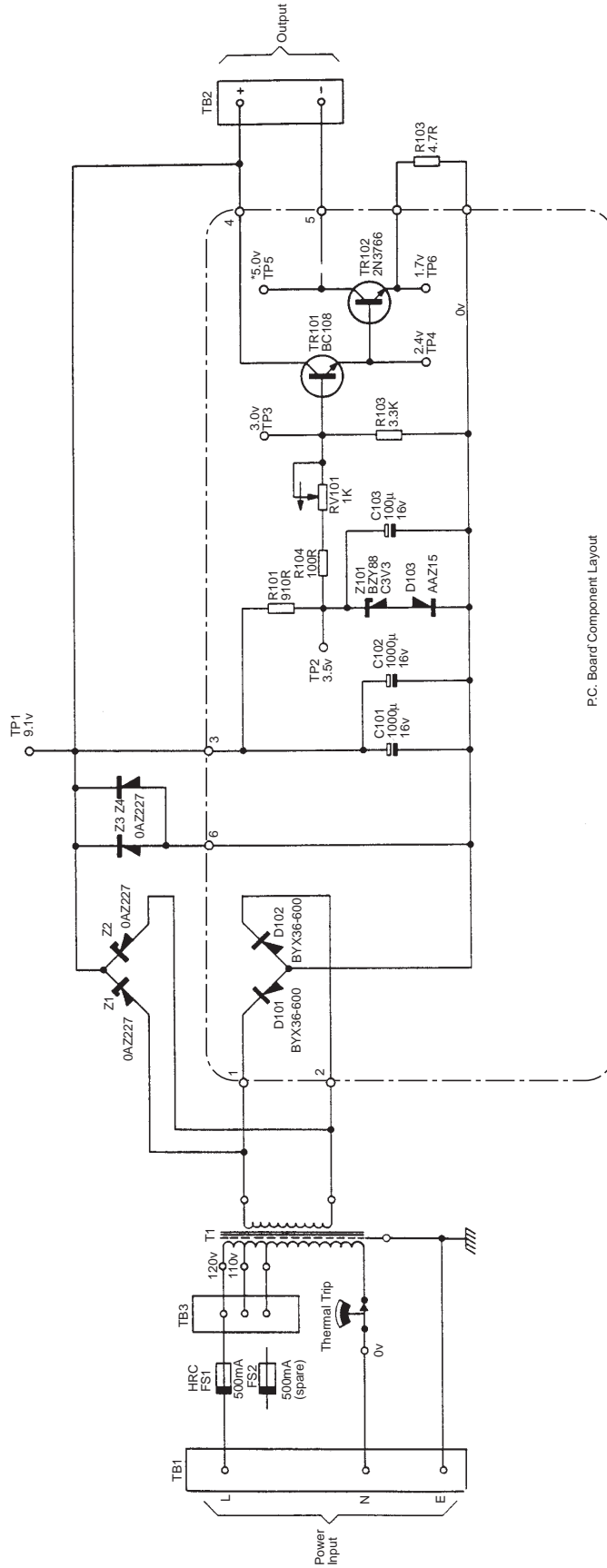

P.C. Board Component Layout

*Measured with a 10R load

Fig. A2 Power Supply Unit Model 4234 – Overall Circuit (110/120 Version)

NOTES

NOTES

NOTES

PRODUCTS & CUSTOMER SUPPORT

A Comprehensive Instrumentation Range

Analytical Instrumentation

- **Transmitters**
On-line pH, conductivity, and dissolved oxygen transmitters and associated sensing systems.
- **Sensors**
pH, redox, selective ion, conductivity and dissolved oxygen.
- **Laboratory Instrumentation**
pH and dissolved oxygen meters and associated sensors.
- **Water Analyzers**
For water quality monitoring in environmental, power generation and general industrial applications including: pH, conductivity, ammonia, nitrate, phosphate, silica, sodium, chloride, fluoride, dissolved oxygen and hydrazine.
- **Gas Analyzers**
Zirconia, paramagnetic, infrared, thermal conductivity.

Controllers & Recorders

- **Controllers**
Digital display, electronic, pneumatic. Discrete single-loop and multi-loop controllers which can be linked to a common display station, process computer or personal computer.
- **Recorders**
Circular and strip-chart types (single and multi-point) for temperature, pressure, flow and many other process measurements.

Electronic Transmitters

- **Smart & Analog Transmitters**
For draft, differential, gauge and absolute pressure measurement. Also, liquid level and temperature
- **I to P Converters and Field Indicators**

Flow Metering

- **Magnetic Flowmeters**
Electromagnetic, insertion type probes and watermeters.
- **Turbine Flowmeters**
- **Wedge Flow Elements**
- **Mass Flow Meters**
Transmitters, sensors, controllers and batch/display units.

Level Control

- **Submersible, Capacitance & Conductivity.**

Pneumatic Instrumentation

- **Transmitters**
- **Indicating Controllers**
- **Recording Controllers**

Customer Support

ABB Kent-Taylor provides a comprehensive after sales service via a Worldwide Service Organization. Contact one of the following offices for details on your nearest Service and Repair Centre.

United Kingdom

ABB Kent-Taylor Limited
Tel: +44 (0)1480 470781
Fax: +44 (0)1480 470787

United States of America

ABB Kent-Taylor Inc.
Tel: +1 716 2926050
Fax: +1 716 2736207

Italy

ABB Kent-Taylor SpA
Tel: +39 (0) 344 58111
Fax: +39 (0) 344 56278

Client Warranty

Prior to installation, the equipment referred to in this manual must be stored in a clean, dry environment, in accordance with the Company's published specification. Periodic checks must be made on the equipment's condition.

In the event of a failure under warranty, the following documentation must be provided as substantiation:

1. A listing evidencing process operation and alarm logs at time of failure.
2. Copies of operating and maintenance records relating to the alleged faulty unit.



The Company's policy is one of continuous product improvement and the right is reserved to modify the information contained herein without notice.

© December 1995 ABB Kent-Taylor Printed in U.K.

ABB Kent-Taylor Ltd.
St. Neots,
Cams.
England, PE19 3EU
Tel: (01480) 475321
Fax: (01480) 217948

ABB Kent-Taylor Ltd.
Analytical & Flow Group
Stonehouse, Glos.
England, GL10 3TA
Tel: (01453) 826661
Fax: (01453) 826358

ABB Kent-Taylor Inc.
PO Box 20550, Rochester
New York 14602-0550
USA
Tel: (716) 292 6050
Fax: (716) 273 6207

ABB Kent-Taylor SpA
22016 Lenno
Como
Italy
Tel: (0344) 58111
Fax: (0344) 56278