



ABB Industry Oy
Power Electronics
P.O. Box 184
FIN-00381 Helsinki
FINLAND
Telephone +358-0-5641
Telefax +358-0-5642681
Telex +57-12440502strfi

1995-03-28

EN 584247 14 B

SAMI GS

Frequency Converters ACS502-506
37 to 315 kW

User's Manual

EN 58424714

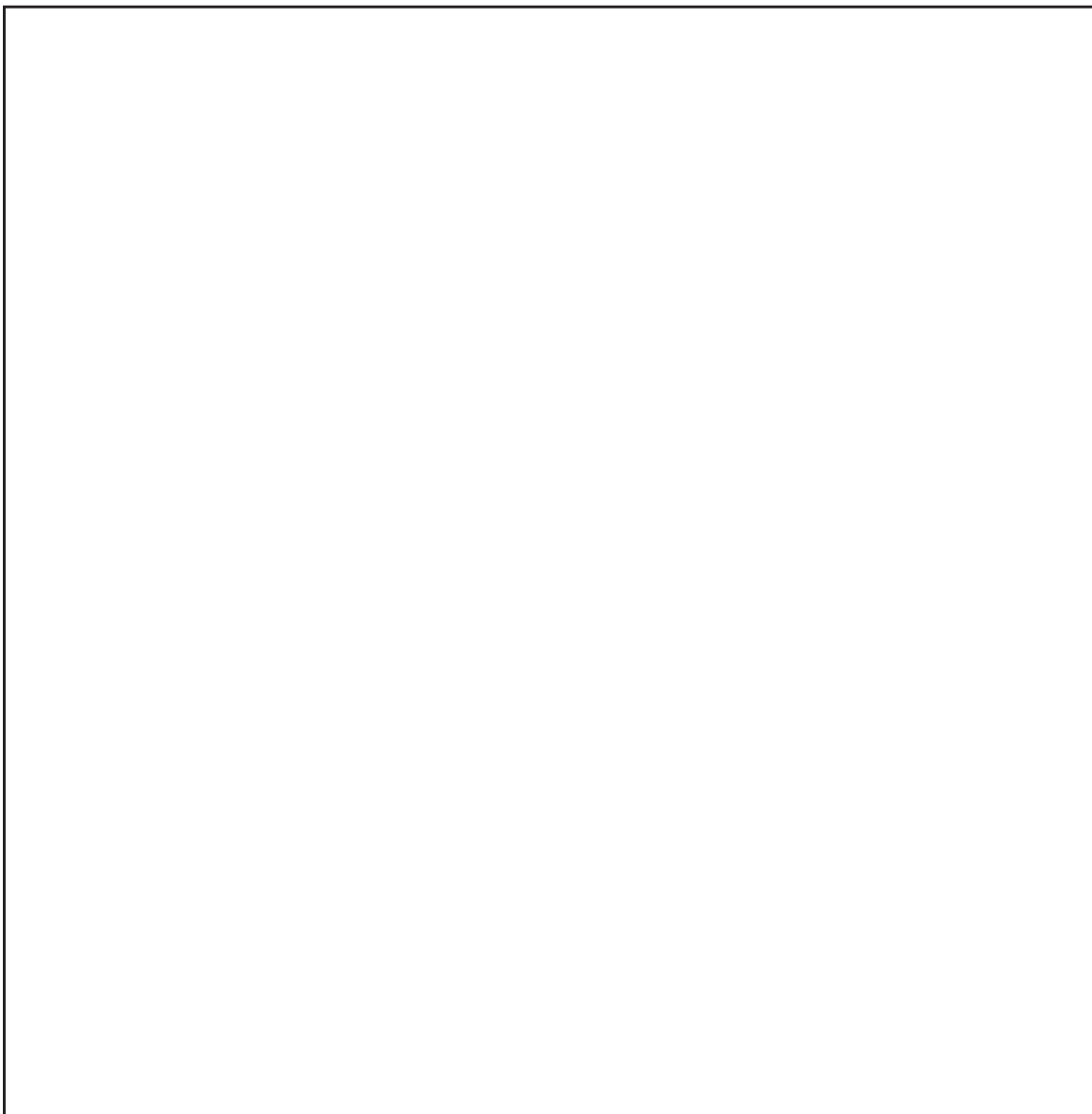

Frequency Converters ACS502-506
37 to 315 kW

User's Manual

Code: EN58424714B

GSHBC-UML2A1/EN
1995-03-28/TH

V:\G\SVBC\315KW\DOC\EN

Safety Instructions



**ONLY A COMPETENT ELECTRICIAN SHOULD
CARRY OUT THE ELECTRICAL
INSTALLATION**



SAMI GS must always be earthed through an earthing conductor connected to the earthing terminal (Protective Earth PE).

If SAMI GS is connected to a system without system earth, the earth fault protection must be capable of starting at earth fault currents containing high frequency and DC components. SAMI GS' earth fault protection guards the frequency converter only against earth faults occurring in the motor or the motor cable.

Fault current circuit breakers do not necessarily operate properly with frequency converters. Circuit breaker function should be checked for possible earth fault currents arising in a fault situation.

Warning symbols

For your own safety please pay special attention to instructions containing these symbols.



Dangerous voltage



General warning

WARNINGS!

SAMI GS contains dangerous voltages when connected to the mains.

Note that the printed circuit cards within the Converter Module of the SAMI GS are at mains supply voltage potential.

The capacitors in the Converter Module are charged to dangerous DC voltage levels. After disconnecting the supply, wait at least 5 minutes after the display readout on the

control panel has disappeared before taking any measurements.

Dangerous external control voltages may be present on the relay outputs of the Control Interface Card and Option Cards.

Pay attention to the following instructions:

- Do not work on the frequency converter when SAMI is connected to the mains.
- Never connect mains voltage to the drive output terminals (U2, V2, W2).
- Do not make any voltage withstand tests on any part of the unit. Disconnect motor cables before taking any measurements on the motor or motor cables.
- Make sure that power factor correction capacitors are not connected between the drive and the motor.
- Do not touch the IC-circuits on the printed circuit boards. Static discharge voltage may destroy the circuit. In general, avoid touching any of the components within SAMI GS.
- Check that the voltage setting of the internal transformer corresponds to the mains voltage.

ALWAYS CHECK THAT SAMI GS IS SAFE BY MEASURING THE DC LINK VOLTAGE BETWEEN TERMINALS UDC+ AND UDC- AND MAINS INPUT VOLTAGE!

The meter for measuring these voltages must withstand 1000 V DC or AC.

Refer to the figure 5-1 on page 20.

Contents

GENERAL

Safety Instructions	2
1 How to Use This Manual	6
2 Delivery Checks	7
3 General Information about SAMI GS	8
3.1 SAMI GS Types and Type Designation	8
3.2 Hardware Description	10
3.3 Functional Description of SAMI GS	15

INSTALLATION

4 Mechanical Installation	17
4.1 Cooling	17
4.2 Installing ACS 502 - ACS 503 Cabinets	18
4.3 Installing ACS 504 Converter Module inside User Defined Cabinet ..	18
5 Power Connections	19
5.1 Mains and Motor Cables	19
5.2 Insulation Checks	20
6 Control Connections	21
6.1 Control Cables	22
6.2 Connections of the Control Interface Card SNAT 7600/7640	23

OPERATION

7 Control and Parameter Logic	24
7.1 Control Panel	24
7.2 Control Panel Operation	24
7.3 Parameter Logic	25
7.4 Adjusting Display Contrast	27
7.5 Operating Data	27
7.6 Control	29

7.7 Keypad Control	30
7.8 External Control	30
7.9 Parameter Lock	31

START-UP

8 Commissioning	31
8.1 Safety Precautions	31
8.2 Sequence of Operations	32
8.3 Installation Inspection	33
8.4 Start-Up Data Parameters	33
8.5 Checking Selected Application Macro Parameters	34
8.6 Keypad Control Test without Motor	34
8.7 Keypad Control Test with Motor	34
8.8 Drive Parameters and Their Factory Settings (Factory Macro).	35
9 Drive Parameters	39
9.1 Main 10 - Control Connections	39
9.1.1 Group 11 - Dig/Analog Input Sel	39
9.1.2 Group 12 - Analogue Inputs	43
9.1.3 Group 13 - Ref Value Scaling	44
9.1.4 Group 14 - Output Signals	44
9.1.5 Group 15 - Analogue Outputs	46
9.1.6 Group 16 - Out Sig Scaling	47
9.1.7 Group 17 - Ext. Communication	48
9.2 Main 20 - Drive	50
9.2.1 Group 21 - Acceler/Deceler	50
9.2.2 Group 22 - Freq/Cur Limits	51
9.2.3 Group 23 - Crit Frequencies	52
9.2.4 Group 24 - Const Frequencies	53
9.2.5 Group 25 - PI-Controller	53
9.2.6 Group 26 - Start/Stop	57
9.2.7 Group 27 - Motor Control	59

9.2.8 Group 28 - PFC Control	62
9.3 Main 30 - Protection	67
9.3.1 Group 31 - Supervision	67
9.3.2 Group 32 - Fault Function	68
9.3.3 Group 33 - Automatic Reset	72
9.3.4 Group 34 - Information	72

SERVICE & MAINTENANCE

10 Fault Tracing & Service	73
10.1 Fault Indications	73
10.2 Fault Resetting	73
10.3 Fault History	73
10.4 Fault Tracing with a Fault Display	75
10.5 Other Fault Situations	81
10.5.1 LED Indications on the Main Circuit Interface Card	82
10.6 Service	83
10.7 Spare Parts	84
11 Technical Data	87
12 Options	88
12.1 Fuse Switches and Contactors	89
12.2 Brake Choppers and Resistors	90
12.3 Earth Fault Protection	92
12.4 RFI Filter	92
12.5 ACS 506	92
13 Glossary	93
14 Index	94

APPENDICES

Dimensional Drawing of ACS 502 (Standard cabinet)	1
Dimensional Drawing of ACS 503 (MD cabinet)	2
Dimensional Drawing of ACS 504 (Module)	3
Dimensional Drawing of ACS 50y-yyy-y-00P (Control unit)	4

1 How to Use This Manual

SAMI GS (ACS 500) is a digital frequency converter series for speed control of standard asynchronous motors. The power range of SAMI GS series covers 2.2 kW to 315 kW at line voltages from 380 V to 500 V. The range is divided into two sub-series:

- compact wall-mounted units 2.2 kW to 75 kW (ACS 501)
- floor-standing units 37 kW to 315 kW (ACS 502 ... ACS 506)

This manual gives instructions for the proper and safe installation, start-up, operation, fault tracing and service of the floor-standing SAMI GS units (ACS 502 ... ACS 506).

We recommend you read this User's Manual carefully before starting any installation and connections or operating your SAMI GS.

SAMI GS user documentation also includes a Quick Reference Guide, Application Macro Manual and Control Panel Operation Instruction Sticker, which are included in the delivery. The sticker is to be placed on the front

cover below the keypad.

For quick and easy use of this manual, please refer to the table of contents on pages 3 - 5 or to the index on pages 93 - 94.

Short explanations of some less commonly used technical terms referred to in this manual are given in the Glossary (page 92).

References to titles of the different sections of this manual are printed with a capital first letter. SAMI GS parameter names and settings are printed in capital letters when mentioned in the text.

Parameters are also referred to by using a number, which indicates the location of the parameter (32.1 means the first parameter in Group 32 of Main 30).

Should there be any questions concerning SAMI GS, please contact the supplier or the manufacturer.

The technical data and specifications are valid at the time of printing. We reserve the right to subsequent alterations.

ABB Industry Oy
Power Electronics
P.O. Box 184
FIN-00381 Helsinki
FINLAND

Telephone: +358-0-5641
Telefax: +358-0-564 2681
Telex: +57-12440502 strfi

2 Delivery Checks

Check that the device does not show any signs of damage and that the delivery is complete (refer to the type designation code presented in table 3-2 on page 9). In the event of damage, please contact your insurance company or the supplier. If the delivery is not in compliance with the order, please contact the supplier immediately.

Check that you have received the following documentation with each unit:

- User's Manual
- Installing ACS 504 Converter Module inside User Defined Cabinet (Appendix to User's Manual)
- Application Macro Manual
- Quick Reference Guide
- Control Panel Operation Instruction Sticker
- Control Record
- Connection Diagram(s)
- Setting Instruction of Transformer T61

If the device is stored before commissioning, check that the environmental conditions in the storage room are acceptable (temperature -40 °C to +70 °C; relative humidity < 95 %, no condensation allowed).

The guarantee covers defects in manufacture. The manufacturer carries no responsibility for damage occurred during transport or unpacking.

Under no circumstances shall the manufacturer be liable for damages and failures due to misuse, abuse, improper installation or abnormal conditions of temperature, dust or corrosives or failures due to operation above rated capacities. Nor shall the manufacturer be liable for consequential and incidental damages.

The period of manufacturer's guarantee is 12 months from commissioning and not more than 24 months from the date of delivery.

Local ABB companies or distributors may have a different guarantee period, which is specified in their sales terms and conditions and guarantee terms.

If any queries arise concerning the SAMI GS, please contact your Distributor or ABB local office.

3 General Information about SAMI GS

3.1 SAMI GS Types and Type Designation

*Table 3-1. Type series and ratings of SAMI GS. **Note!** When units are used at lower line voltages, the output current ratings must still not be exceeded. The available power is reduced in proportion to the reduction in voltage. The motor power ratings must not be exceeded, even if the output current is smaller due to better power factor of the motor.*

Voltage U_1	Type ACS50x	Constant Torque				Squared Torque			
		I_1	I_N	I_{Nmax}	P_N	I_{1sq}	I_{Nsq}	I_{NSQmax}	P_{Nsq}
380 V	051-3-...	67	76	114	37	80	89	98	45
400V	061-3-...	81	89	134	45	98	112	123	55
415 V	071-3-...	100	112	168	55	133	147	162	75
	100-3-...	134	147	221	75	159	178	196	90
$\pm 10\%$	120-3-...	160	178	267	90	194	216	238	110
50/60Hz	140-3-...	196	216	324	110	232	260	286	132
	170-3-...	234	260	390	132	281	316	348	160
	210-3-...	284	316	474	160	350	395	435	200
	260-3-...	354	395	593	200	435	480	528	250
440 V	061-5-...	62	65	97.5	45	75	84	93	55
460 V	071-5-...	77	84	126	55	102	112	123	75
480 V	100-5-...	102	112	168	75	121	135	149	90
500 V	120-5-...	123	135	202	90	148	164	181	110
	140-5-...	150	164	246	110	177	200	220	132
$\pm 10\%$	170-5-...	179	200	300	132	214	240	264	160
50/60Hz	210-5-...	218	240	360	160	267	300	330	200
	260-5-...	271	300	450	200	332	365	402	250
	320-5-...	337	365	547	250	418	460	506	315
575 V	071-6-...	68	77	115	55	88	99	109	75
600 V	100-6-...	88	97	145	75	110	125	137	90
$\pm 10\%$	120-6-...	110	125	187	90	133	150	165	110
50/60Hz	170-6-...	152	172	258	132	185	209	230	160

U_1	rated supply voltage [V]
I_1	input current (rms) when shaft power is P_N , line voltage is 380 V, 500 V or 600 V and the motor is a standard ABB 6-pole motor [A]
I_N	nominal output current in constant torque applications [A]
I_{Nmax}, I_{NSQmax}	short term maximum output current [A] (allowed for 1 min every 10 min)
P_N	max motor nominal shaft power in constant (P_{Nsq}) squared torque applications (2-,4-,6-pole ABB standard motor) [kW]
I_{1sq}	input current (rms) when shaft power is P_{Nsq} , line voltage is 380 V, 500 V or 600 V and the motor is a standard ABB 6-pole motor (max thermal input current) [A]
I_{Nsq}	nominal output current in squared torque applications [A]

SAMI GS

Apart from different voltage and current ratings, the SAMI GS is also available in various different configurations: enclosure, optional control cards, internal brake chopper etc.

The configuration of the SAMI GS you have can be decoded from the type designation of your SAMI. This designation appears on the name plate of the SAMI and also on the SAMI's Control Record.

Note! There is also a name plate on the Control Unit and another on the Converter Module.

The key to the type designation is in Table 3-2. There are three enclosure types - module (IP 00), standard stand-alone cabinet (IP 21 or IP 54) and MD industry cubicle (IP 21). The latter two have a fuse switch at the mains input.

*Table 3-2. Type designation key of SAMI GS. **Note!** The code may be truncated if the remaining digits are irrelevant. An X in the code means that the corresponding property is irrelevant for the unit in question. Note that the table below includes combinations that are not available for every enclosure types.*

ACS 502-071-5-00P20A000			
ACS	Standard AC-Drive		
50	SAMI GS family		
2	Enclosure	2=standard cabinet 3=MD industry cubicle	4=module 6=12 pulse bridge (IP 00)
071	Rated power (kVA)		
5	Supply voltage	3=380 V/400 V/415 V 5=440 V/460 V/480 V/500 V	6=525 V/550 V/575 V/600 V (IP 00)
0	Option card in slot 1	0=No option card	3=SNAT 7610 BAC
0	Option card in slot 2	0=No option card	2=SNAT 7520 IOE
P	Control panel	0=No control panel	P=Standard control panel
2	Protection class	0=IP 00 5=IP 54	2=IP 21
0	Optional internal brake chopper	0=no brake chopper 2=brake chopper + resistor	1=brake chopper
A	Optional input devices	0=no input devices A=line contactor & emergency stop B=thermistor relay C=options A+B	D=earth fault protection E=options A+D F=options B+D G=options A+B+D
0	Motor fan starter	0=no motor fan starter supply 1=supply with 1...1.6 A thermal switch 2=1.6...2.5 A thermal switch 4=4...6 A thermal switch	3=2.5...4 A thermal switch
0	Cubicle Heater and Control Terminal Block	0=no heater or term. block 2=control terminal block	1=heater 3=options 1+2
0	Line & Output filters	0=no options	1=input filter + cabinet 3=empty cabinet

3.2 Hardware Description

The SAMI GS consists of a Control Unit and a Converter Module.



Warning! Parts within the Converter Module are at mains circuit potential, whereas the printed circuit cards within the Control Unit are earthed.

In enclosed versions (IP 21 or IP 54) there is always a fuse switch and possibly some optional equipment outside the Converter Module. Refer to the type designation key to determine options included in your SAMI. The block scheme of SAMI GS (with all options) is presented in Figure 3-1.

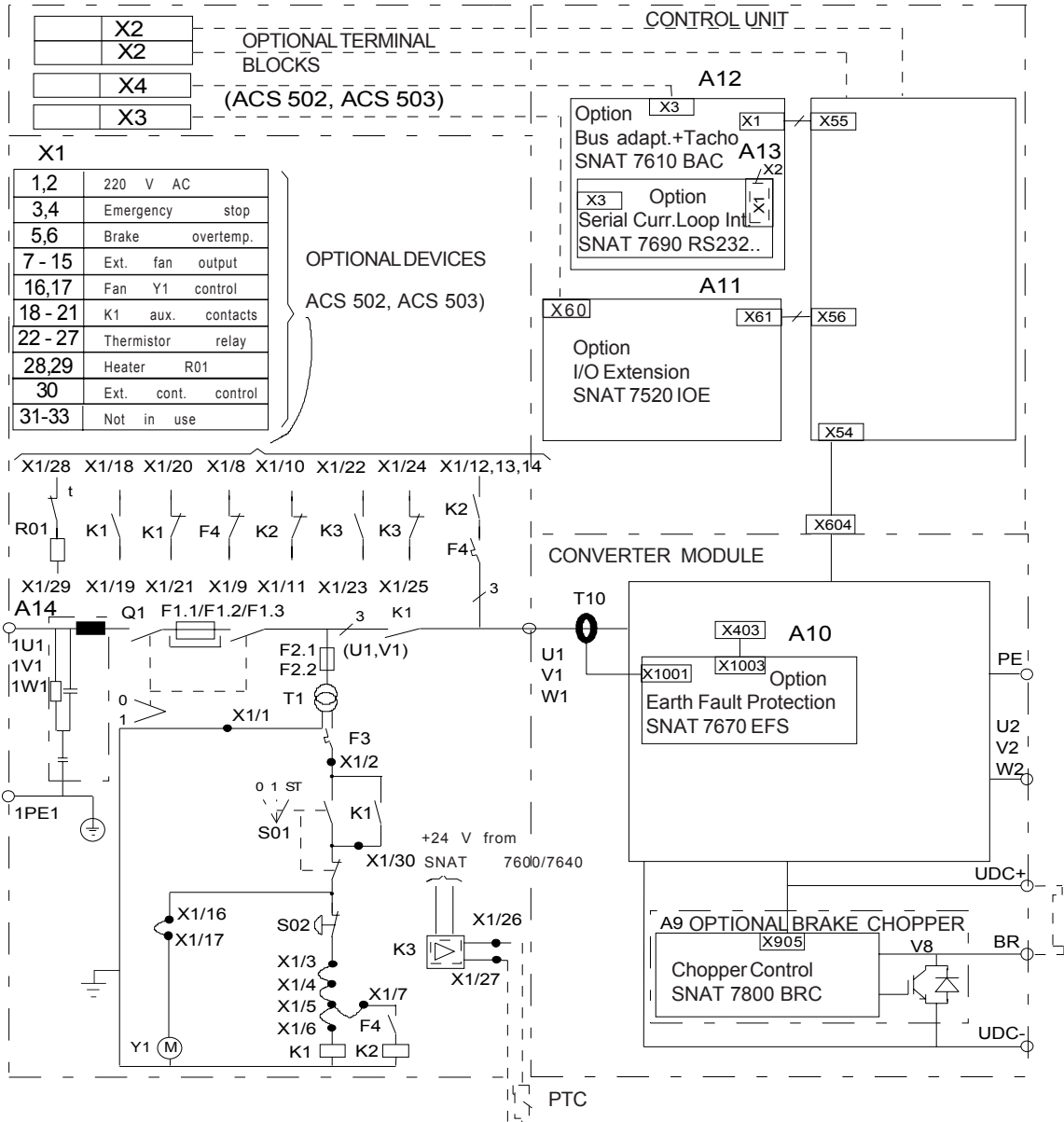

Figure 3-1. Block diagram of the optional equipment for the SAMI GS (see tables 3-5 and 3-6).

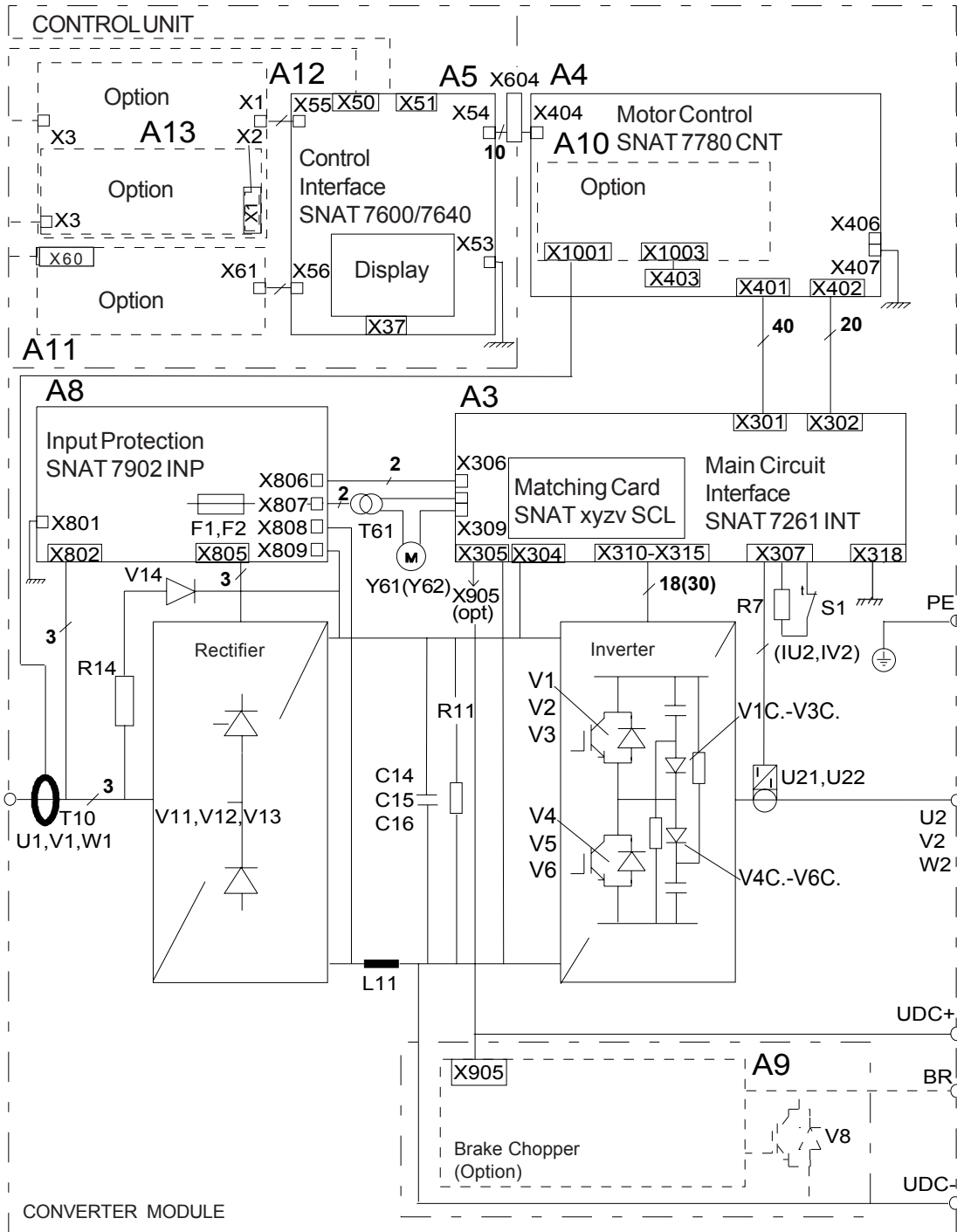

Figure 3-2. Block diagram of the Converter Module and the Control Unit (see tables 3-3 and 3-4).

**SAMI
GS**

Table 3-3. Part list of the Converter Module.

Part code	Description
R14, V14	Charging circuit
V11, V12, V13	Rectifier bridge
A8	Input Protection Card SNAT 7902 INP (SNAT 7903 INP for 600 V units). This card contains gate trigger circuits for the rectifier thyristors together with capacitors and varistors to protect the bridge as well as the fuses to protect the fan.
L11, C14.1... C16.N, R11	DC-filter choke and capacitors, discharge resistors (AC choke on line side in 600 V units)
V1 ... V6	Inverter insulated gate bipolar transistors (IGBT).
V1C. V6C	Clamp diodes.
A3	Main Circuit Interface Card SNAT 7261 INT (SNAT 7266 INT for 600 V units). This card contains mainly the power supply, transistor gate trigger circuits, DC-voltage and motor current measurement circuits.
A4	Motor Control Card SNAT 7780 CNT.
A7	Matching Card SNAT xyzv SCL. A small card on top of SNAT 7261 INT containing the power range programming information for that particular SAMI hardware. (SNAT xyzv SCL, where xyz = kVA rating and v = 3 in 400 V units, v = 5 in 500 V units and v = 6 in 600 V units.)
U21, U22	Current transducers
Y61, (Y62)	Cooling fan(s) and associated transformer T61. Note! The transformer connection has to be made according to the actual supply voltage.
R7	The temperature of the heatsink is measured by means of R7. A thermostat (S1) is in series with it providing thermal protection for those components that are not covered by R7.
(V8, A9)	Optional braking chopper: consisting of a transistor and its control card SNAT 7800 BRC. The braking resistor is mounted outside the module. In MD cubicle versions it is mounted in the adjoining cubicle. For ratings of the braking chopper and resistor, see Section 12 - Options.
(A10, T10)	Optional Earth Fault Protection SNAT 7670 EFS with current transformer at the line side (T10). For settings, see Section 12 - Options.

**SAMI
GS**

Table 3-4. Part list of the Control Unit.

Part code	Description
A5	The Control Interface Card SNAT 7600/7640 contains the display and keypad together with a terminal block, X50 for control wiring. RS 485 terminal block X51 and some programming jumpers for analogue inputs are on this card.
(A11, A12, A13)	Option cards: SNAT 7610 BAC, SNAT 7690 RS232/20 mA, SNAT 7520 IOE (see Section 12 - Options)

Table 3-5. Parts of the main circuit in enclosed versions of SAMI GS.

Part code	Description
Q1, F1.1... F1.3	Fuse load switch and fuses. The ratings of the fuses are given in Table 5-1.

Table 3-6. Optional parts in enclosed versions of SAMI GS.

Part code	Description
K1	Line contactor with three auxiliary contacts (1NC + 2NO). One of the NO auxiliary contacts is reserved for the contactor tripping circuit, the other contacts are connected to terminal block X1/18 - 21. With this option, control switch S01 (installed in the door), emergency stop switch S02 (installed in the door), transformer T1, circuit breaker F3 and fuses F2.1 and F2.2 are included. An input for external tripping of K1 is provided at terminals 3 and 4 of terminal block X1.
K2, F4	<p>The terminals 2U2, 2V2, 2W2 and 2PE (terminal numbers 12 - 15 of terminal block X1) provide an auxiliary three-phase output (voltage U_1) for the cooling fan of a separately ventilated motor.</p> <p>Thermal switch F4 must be specified separately, according to the nominal current of the fan motor. The possible setting ranges are:</p> <p>1) 1 ... 1.6 A 2) 1.6 ... 2.5 A 3) 2.5 ... 4 A 4) 4 ... 6 A</p> <p>Terminals 5 and 7 of terminal block X1 can be used for external control circuitry of K2 (it is suggested that one of the Relay Outputs (RO1..RO3) is programmed as RUN to control the fan of the separately ventilated</p>

**SAMI
GS**

Table 3-6 continues from page 13...

	motor). Note! Tripping K1 leads to K2 tripping. The aux. contacts of K2 and F4 are connected to terminal block X1/8 - 11.
Part code	Description
K3	Thermistor relay for motor thermal protection. The thermistors are connected to terminal block X1, terminals 26 and 27. The auxiliary contacts of K3 are connected to terminal block X1/22 - 25 (1 NC + 1 NO).
	The relay is self-resetting: Switch-OFF resistance $3 \pm 0.6 \text{ k}\Omega$, switch-ON resistance 0 ... 1.5 k Ω
R01	Cubicle heater equipped with a thermostat. This option requires an external 220 V/16 A supply at terminal block X1 terminals 28 and 29.
X2 the	Optional terminal block wired to the Control Interface Card SNAT 7600/7640 in the Control Unit.
Y1	In IP 54 enclosed cabinets, there is an extra fan at the top of the cabinet to increase the pressure at the air inlet filters (also transformer T1, fuses F2.1 ... F2.2 and circuit breaker F3 are included in this option). Terminals 16 and 17 of terminal block X1 can be used for external control circuitry of Y1 (it is suggested that one of the Relay Outputs (RO1..RO3) is programmed as RUN, to control the fan of the separately ventilated motor).
X1	Terminal block for the above mentioned options. The terminals fit for 1.5 ... 4 mm ² wires.

3.3 Functional Description of SAMI GS

Note! There is space for additional relays above terminal blocks.

(A14) RFI Filters to reduce electromagnetic emission to nearby equipment (see Section 12 - Options).



Power-on sequence

When the line voltage is initially switched on, the capacitor bank is charged via the charging circuit. The charging takes less than one second. During this time, the thyristors of the rectifier bridge are not conducting.

Warning! The maximum permissible number of charges within one minute is four. If the DC-link is charged more often than this, the charging resistor may fail due to excessive heat. It is therefore not recommended to use the input contactor as a Start/Stop command for frequent duty cycles.

The power supply for the SAMI GS is fed from the capacitor bank. The power supply turns on, when the voltage on the capacitors reaches about 300 V. Subsequently, the Control Interface Card, Motor Control Card and Main Circuit Interface Card are energized.

When the DC-voltage has reached 80 % of its nominal value (see below), the processor on the Motor Control Card energizes the Input Protection Card. The thyristors are switched on, fully conducting, and the thyristor-diode rectifier behaves like a normal diode bridge.

The cooling fan also turns on at initial power-on. To prolong the useful life of the fan bearings, SAMI GS incorporates logic to turn the fan off after one minute, unless:

- the SAMI GS has got a RUN command, or
- the heatsink temperature is above 45°C

Normal duty, control

In normal duty the SAMI GS follows the commands and references given to it either from the keypad or terminal block on the Control Interface Card. The control signal source selection and the way SAMI GS interprets these signals are configured by parameters.

See Sections 6, Control Connections, 7, Control and Parameter Logic and 9, Drive Parameters (Group 11 Control Connections).

For drive related parameters, such as acceleration or deceleration times, start and stop modes, constant speeds, PI-controller values or output frequency, voltage and current limits, see Section 9, Drive Parameters (Groups 21 through 27).

Normal duty, main circuit

Power flow through a SAMI GS in normal duty is from AC-mains through the rectifier bridge to the DC-filter capacitors, which sustain a constant DC-voltage. The nominal value for this voltage is $1.35 * U_L$ (U_L actual line voltage).

The Inverter consists of 6 power semiconductor switches, whose operation is controlled by the Motor Control Card via the Main Circuit Interface Card. Turning these switches on and off in a certain sequence is called modulation. The modulation frequency in SAMI GS is about 3 kHz maximum.

The potential at any terminal U2, V2, W2 of the Inverter can only be high or low; the modulation determines which one. At any instant, the line to line output voltage is therefore either 0 V (when the switches in these phases are in the same position) or $+1.35 * U_L$ (when the corresponding switches are in different positions).

The output voltage wave-form is a pulse-train. The width of the pulses vary according to the modulation. The purpose of the modulation is to create the fundamental voltage wave (its amplitude and frequency), according to the law $U_2/f_2 = \text{constant}$.

The distortion of the output voltage from the sinusoidal fundamental creates corresponding harmonics in the motor current. However, since the motor is highly inductive and the modulation frequency is relatively high, the current wave-form is nearly sinusoidal.

Protective features

Should something adverse happen during power-up or normal duty, SAMI GS incorporates several protective features to protect itself:

- internal overtemperature (warning and trip)
- overcurrent (current limit and trip)
- mains phase loss/unbalance (trip)
- overvoltage (trip at 130 % nominal DC-voltage)
- undervoltage (trip at 65 % nominal DC-voltage)
- starting at overvoltage (>117 % of nominal DC-voltage inhibits start. See Section 10.5.)
- in addition various internal and external hardware faults are identified and a diagnostic message is given

SAMI GS also incorporates a variety of protective features for the motor, including:

- stall (warning and trip)
- overload (warning and trip)
- underload (warning and trip)

More information on these protective and diagnostic features can be found in Section 10, Fault Tracing. Some of them are selectable or programmable, see also Section 9, Drive Parameters (Group 31 Supervision, Group 32 Fault Function).



Power-off sequence

Warning! After the line voltage is disconnected, a high voltage remains on the capacitor bank, which is discharged through discharge resistors (R11) within five minutes.

4 Mechanical Installation

Always ensure by voltage measurement that the voltage has dropped before performing any service or making main circuit connections. (Measure between terminals UDC+ and UDC-. The meter must be capable of withstanding 1000 VDC.)

The dimensional drawings of the SAMI GS Converter Modules and Control Unit are in the Appendices 3 and 4, respectively. The dimensional drawings of SAMI GS in standard cabinet and MD cubicle are in Appendices 1 and 2, respectively. The weights given are approximate.

4.1 Cooling

SAMI GS frequency converters are provided

For design purposes, the maximum total power losses, required cooling air volumes and free

with one (or two) cooling fan(s) on the bottom of the unit. In IP 54 units there is an additional fan at the top of the enclosure.

The maximum allowed ambient temperature (temperature of the air entering the unit) is 40 °C.

When installing the Control Unit in an enclosure, ensure that the temperature of the air surrounding the Control Unit does not exceed 50 °C.

The cooling air must be clean and free from corrosive agents (according to ISA-S71.04 G1). Where necessary the cooling air should be filtered.

400V Units	P W	Q_v m ³ /h	500V Units	P W	Q_v m ³ /h	Required free space [cm] to all directions outside the air inlets and outlets ¹⁾
051-3-...	1500	300	061-5-...	1750	300	20
061-3-...	1750	570	071-5-...	2500	570	20
071-3-...	2500	570	100-5-...	3000	570	20
100-3-...	3000	690	120-5-...	3500	690	30
120-3-...	3500	690	140-5-...	4250	690	30
140-3-...	4250	1350	170-5-...	5250	1350	40
170-3-...	5250	1350	210-5-...	6500	1350	40
210-3-...	6500	1800	260-5-...	8000	1800	50
260-3-...	8000	1800	320-5-...	10000	1800	50
600 V Units			071-6	2800	570	-
			100-6	3300	690	-
			120-6	3900	1350	-
			170-6	5800	1800	-

¹⁾ Only ACS 502 and ACS 503.



space requirements are tabulated below. The losses occur when the output current is I_{Nsq} and the input current I_{1sq} . The temperature rise of the cooling air with these air volumes and losses is below 18 °C.

Table 4-1. Power losses, cooling air volumes and free space requirements of SAMI GS.

Note! When planning or inspecting the installation of a SAMI GS, pay special attention to the cooling air flow. Prevent the air from recirculating from the outlet of the unit back to the inlet. This is of special importance when installing an IP 00 module (ACS 504-..) in a cubicle, where careless lay-out and inadequate channelling may lead to recirculating air flow, and thus excessive temperature rise within the cubicle.

If the cooling air contains dust, clean the cooling surfaces of the unit regularly using compressed air and a brush. If there are filters at the air inlet of the enclosure, check their condition regularly and replace if needed.

If the cooling ability is reduced too much, the thermal protection of the SAMI GS operates causing a fault indication and stopping the frequency converter. The SAMI GS can be started again when the temperature of the heatsink has fallen below the tripping level (85°C).

The temperature of the heatsink can be read from the control panel display (Operating Data, parameter 8, SAMI TEMPERATURE).

The difference between the heatsink and ambient temperature is an indication of the prevailing cooling conditions, and can thus be utilised in preventive maintenance or in installation inspection. When the SAMI has been running at I_N for more than half an hour, the difference should be less than 25°C. When the SAMI has been running at I_{Nsq} (at f_2 50Hz) for more than half an hour, the difference should be less than 30°C.

4.2 Installing ACS 502 - ACS 503 Cabinets

The cabinet must be transported either on a pallet built under it or by the roof lifting lugs. The cubicle may be laid down on its back for moving through doors etc.

The cubicles are designed to be placed free standing on a level base or across a cable duct. The cubicle can be fastened to the base through the holes in the bottom by using 10 mm bolts. Weld mounting to the base cannot be used.

Whenever installing the ACS 502 - ACS 503 in cabinets take care that the required amount of cooling air is available in the installation room and the required free space round the cabinet is taken into account (see Table 4-1). Notice also the other requirements mentioned in Section 4.1.

The cubicles have to be installed with at least 150 mm free space in front of the air inlets and outlets.

Exception: The air outlets of ACS 503 on the back are allowed to be blocked (back to wall mounting).

Note! The ACS 502 types:

ACS 502-140-3 and 170-3

ACS 502-170-5 and 210-5

have air outlets on the right side (side to side mounting is not possible).

4.3 Installing ACS 504 Converter Module inside User Defined Cabinet

The converter takes in cooling air through the lower front of the module. The air intake must not be obstructed by any objects or structures. The converter module has to be installed into the cubicle with enough free

5 Power Connections

space round the module. The minimum dimensions are listed in Section 4.3 of separate manual Installing ACS 504 Converter Module inside User Defined Cabinet, which is one of the delivery documents. Notice also that the cooling air must not circulate inside the cubicle. (See the section 4.2 of the separate manual Installing ACS 504 Converter Module inside User Defined Cabinet).

5.1 Mains and Motor Cables

The cross sections for the cables can be determined according to the current values mentioned in Table 3-1. The maximum I^2t ratings for the input fuses to be used with the

IP00 module can be found in Table 5-1 (ratings of the fuses in enclosed versions of the SAMI GS are equal to these). Screened cables are recommended as unshielded cables may lead to unwanted problems in electrical noise emission. Recommended tightening torque for the cable connections is 30 ... 44 Nm.

Note! Remove all the compensation capacitors from the line side so that they are not powered up at the same time as the SAMI GS.

Check that the supply capacity is adequate for the SAMI (P_N or P_{Nsq}). The short circuit power of the supply network must not exceed

20 MVA at the SAMI terminals, otherwise the clearing capacity of the input fuses may be

Type ACS 50X-...		Mains and motor terminals			Fuse Ratings		
		U1, V1, W1	U2, V2, W2	PE	A	kA ² s	V
400V	500V						
051-3-...	061-5-...	M10	M10	2*M10	125	16	660
061-3-...	071-5-...	M10	M10	2*M10	160	28	660
071-3-...	100-5-...	M10	M10	2*M10	200	28	660
100-3-...	120-5-...	M10	M10	2*M10	250	153	660
120-3-...	140-5-...	M10	M10	2*M10	315	186	660
140-3-...	170-5-...	M10	3*M12	2*M10	350	186	660
170-3-...	210-5-...	M10	3*M12	2*M10	400	471	660
210-3-...	260-5-...	M10	3*M12	2*M10	500	471	660
260-3-...	320-5-...	M10	3*M12	2*M10	630	471	660
600 V	071-6-...	M10	M10	2*M10	160	27	660
	100-6-...	M10	M10	2*M10	200	135	660
	120-6-...	M10	3*M12	2*M10	250	170	660
	170-6-...	M10	3*M12	2*M10	400	414	660

SAMI GS

exceeded.

Connect the power connections in accordance with Figure 5-1 on page 20. Note that the input fuses (in Table 5-1) to protect the frequency converter are of the ultra-fast type.



Examples of fuses are presented on page 2 of the separate manual *Installing ACS 504 Converter Module inside User Defined Cabinet (for ACS 504 Converter Module)*.

Table 5-1. Terminal sizes and input fuse

CONTROL CABLING

Note! TE for cable screen is grounded. Ground the screen only at frequency converter end.

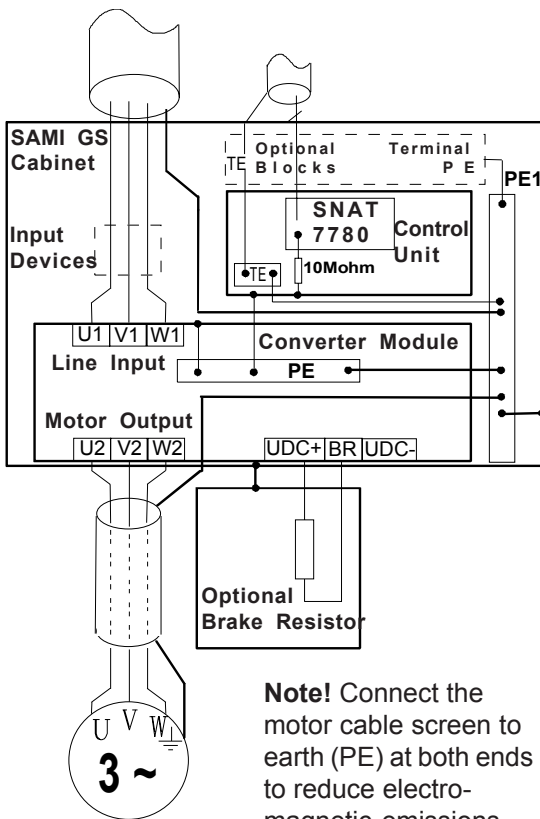

ratings.



Precautions with the Motor Cable

Install the motor cable away from other cable routes. Avoid parallel runs with other cables. If noise problems exist, contact ABB for more detailed information (see page 22).

Note! When retrofitting an existing motor with a SAMI GS, make sure that there is no other circuitry connected to the motor. For example, remove power factor correction capacitors.

Figure 5-1. Mains and motor connections.

Warning! The brake control terminals carry a dangerous DC voltage (>500 V). No device other than an ABB dynamic braking device may be connected to the UDC+, BR and UDC- terminals.

5.2 Insulation Checks

Note! Insulation checks must be performed before connecting the SAMI to the mains. Before proceeding with the insulation resistance measurements make sure that the SAMI is disconnected from the mains.

Do not make insulation checks on the SAMI GS, unless there is reason to suspect an isolation failure. Every unit has been tested for isolation between main circuit and chassis (2500 V rms for 1 minute) at the factory. A retest should not exceed 85 % of the original level under any circumstances.

Check that the motor cable is disconnected from the SAMI output on terminals U2, V2 and W2. Check that the motor cable is disconnected from the motor and remove bridging connections at the motor.

Measure the insulation resistances from the motor. The voltage range of the insulation resistance meter must be at least equal to the mains voltage, but not exceeding 1000 V. The insulation resistance must be greater than 1 MΩ.

20 **Note!** Do not connect the motor cable before proceeding with the Keypad control test without motor, see Section 8, Commissioning.

6 Control Connections

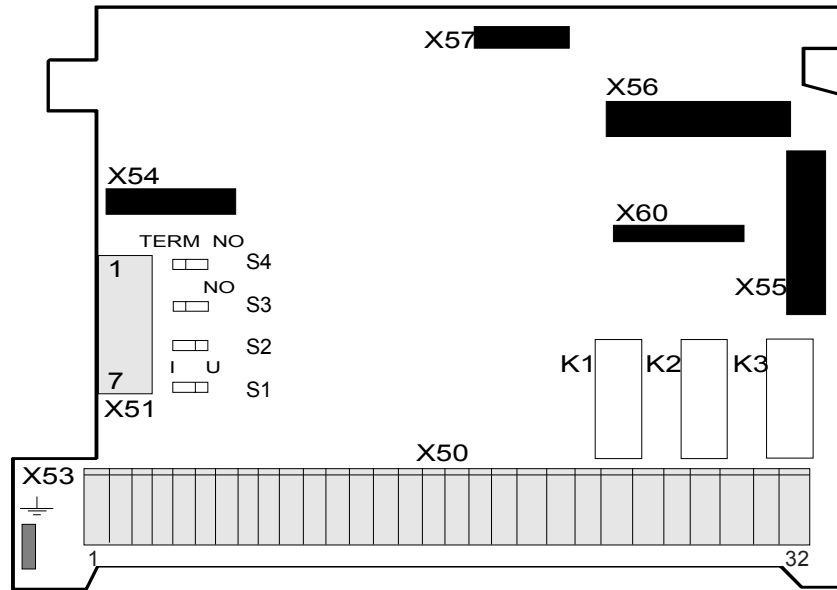

Figure 6-1. Control Interface Card SNAT 7640.

The Analogue Input signal selection is done with jumpers S1 (AI1) and S2 (AI2):
 $I = 0(4) - 20 \text{ mA}$, $V = 0(2) - 10 \text{ V}$.

X50 = screw terminal, X53 = earthing connector, X54 = connection to Motor Control Card,
 X55 and X56 = option card connectors.

X51 for RS 485 connection. Jumpers S3 and S4 are set to TERM in the last SAMI GS unit of a
 RS 485 chain.

The available control places for SAMI GS are:

- Keypad (see Section 7, page 24)
- The X50 screw terminal on the Control Interface Card SNAT 7600/7640 in the Control Unit (This terminal may have been routed to the optional Terminal Block X2 in the cabinet outside the Control Unit).
- The RS 485 serial communication bus; terminal X51 on Control Interface Card (This terminal may have been routed to the optional Terminal Block X2 in the cabinet outside the Control Unit).

External control devices, for example a PLC or a remote control panel SACE 11 PAN, are connected to the screw terminal X50 according to the connection diagram of each Application Macro. The connection diagrams for Application Macros are presented in the Application Macro Manual.

The X50 connection diagram based on factory settings is presented in Section 6.2 on page 23. The terminal functions can be altered by means of parameter settings (refer to Section 9).

Some basic functions are selected by setting the jumpers on the Control Interface Card. Refer to Figure 6-1.

The Control Interface Card is accessible after removing the front cover of the Control Unit. To remove the cover, loosen slightly the four screws on the top and bottom of the cover.

6.1 Control Cables

Control cables for the SAMI GS should be 0.5 - 1.0 mm² screened, multi-core cables, if they are connected to the terminals on the Control Interface Card. Cables up to 4 mm² may be used if the optional Terminal Block X2 is used.

The the cable screens should be earthed at the TE terminal of the Control Unit.

When planning the cabling between the SAMI GS and an automation device, such as a PLC, attention should be given to interference suppression, signal levels, galvanic isolation, etc. The cables should be separated from the mains and motor cables and not running in parallel with them (minimum separation 300 mm if parallel run \leq 10 m; add 300 mm for every 10 m). There should be no additional control components (contactors or relays) inside the SAMI GS and no control cables other than those of the SAMI GS.

The control connections of the SAMI GS are galvanically isolated from mains potential and have a 10 M Ω resistance from the inverter frame i.e. PE. Because of this, there is no need to connect X50/2,4,6 and 8 (logic GND) to TE or PE. However, if EMC problems occur it could prove useful to do this.

Analogue input and output signals:

A separate twisted pair must always be used for each individual signal.

Digital inputs:

It is strongly recommended to use screened cables for digital inputs (DI). An external + 24 V supply for the digital inputs (DI1 to DI6) must not be used.

Relay outputs:

If relay outputs (RO) operate on 24 V DC, the signals can be routed to the same cable used for the digital inputs. If twisted cables are used, digital output and input should never be in the same pair. If 110 V/230 V AC is connected to a relay output, a separate cable without screen can be used for these signals.

Note! If the relay outputs are used to control inductive loads (e.g. relays, contactors) they must be protected by using varistors or RC units (AC) or a diode (DC). The protection components should be installed onto the coil of the relay or contactor being controlled and not on the terminals of X50. When using an RC unit, the leakage current of the RC circuit must be less than the holding current of the controlled contactor or relay.

6.2 Connections of the Control Interface Card SNAT 7600/7640 (factory settings).

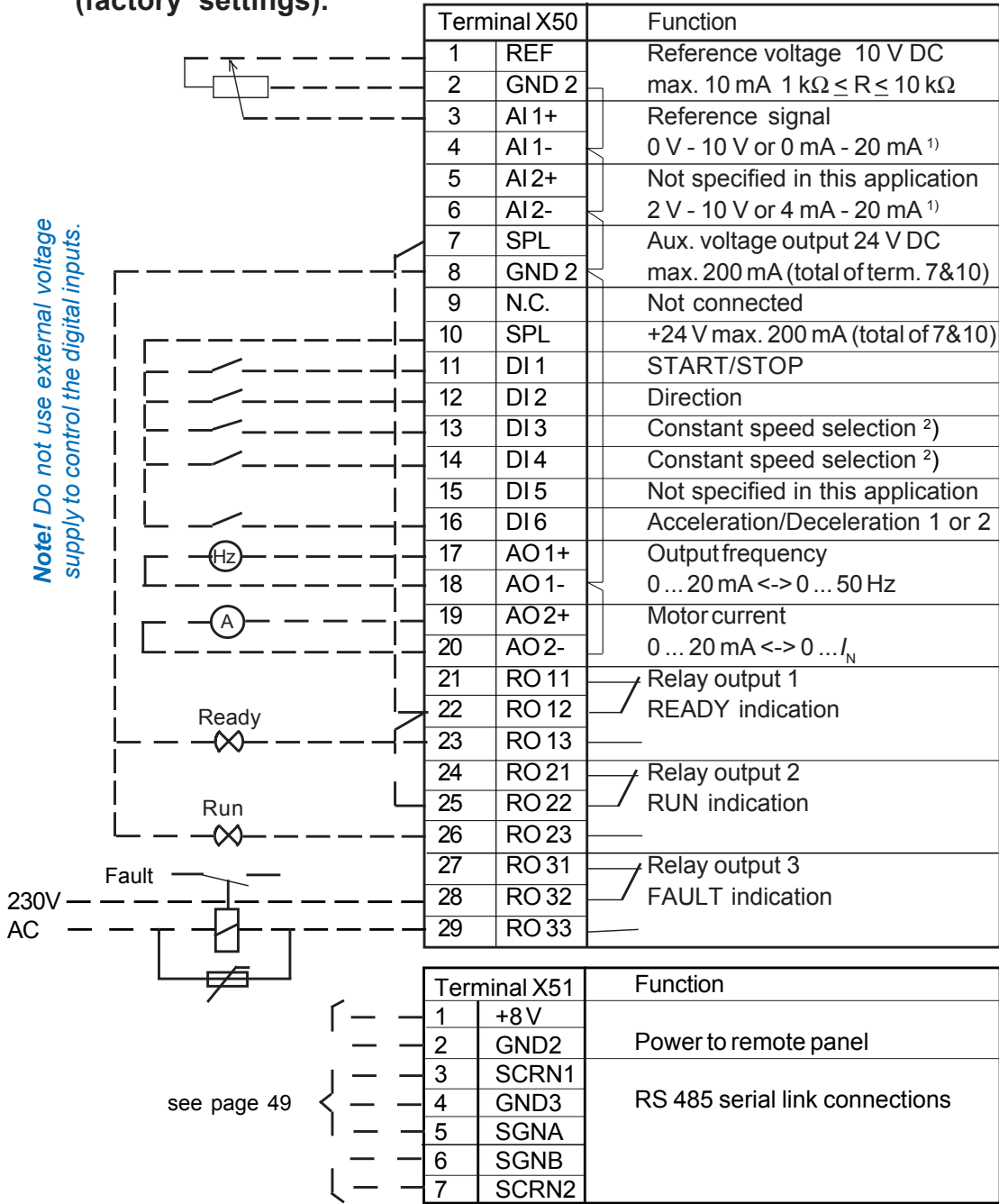

- 1) Select voltage or current reference with jumpers S1 and S2 on the Control Interface Card (located besides the terminal X51).
- 2) Refer to parameter 11.7. CONST SPEED SEL on page 42.

7 Control and Parameter Logic

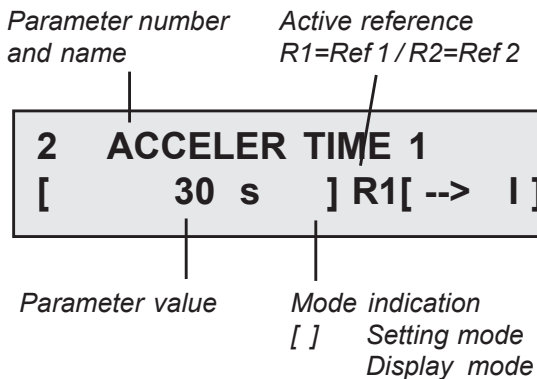
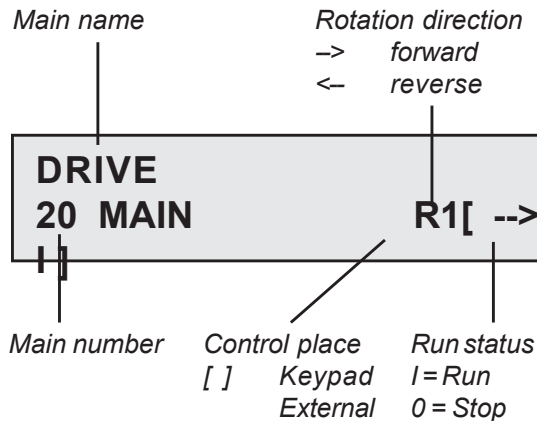

Figure 7-1. Control panel displays. Note that all the indications may not be visible at the same time.

7.1 Control Panel







The control panel, situated on top of the Control Interface Card, incorporates a 2 by 20 character, alphanumeric LCD and a keypad.



The operational information, parameters, as well as fault indications are displayed in nine languages^{*)}: English, Finnish, Swedish, German, Dutch, French, Danish, Spanish and Italian. The language selection is made in Start-Up Data Group parameter A LANGUAGE (refer to page 33).

*) Factory setting is English

7.2 Control Panel Operation

Panel keys

-  Selects the Setting mode and saves the selected parameter value.
-  Selects Operating Data as well as Main, Group and Parameter levels. In Setting mode, returns to the Display mode without changing the Parameter value.
-  In Display mode selects the next/previous Main, Group or Parameter. In Setting mode increases/decreases parameter value.
-  In Display mode selects the next/previous Main, Group or Parameter.
-  In Setting mode increases/decreases parameter value.
-  Changes the rotation direction in Keypad control (refer to parameter 11.8 on page 42).
-  Starts and stops the motor in Keypad control. Resets faults, warnings and supervision indications.

Note! To accelerate the rate of change of parameter value, keep the  or  button depressed continuously.

7.3 Parameter Logic

Note! When the power is switched on, the last parameter displayed before the unit was switched off is displayed except for Start-up Data parameters (SAMI OUTPUT FREQ will be displayed).

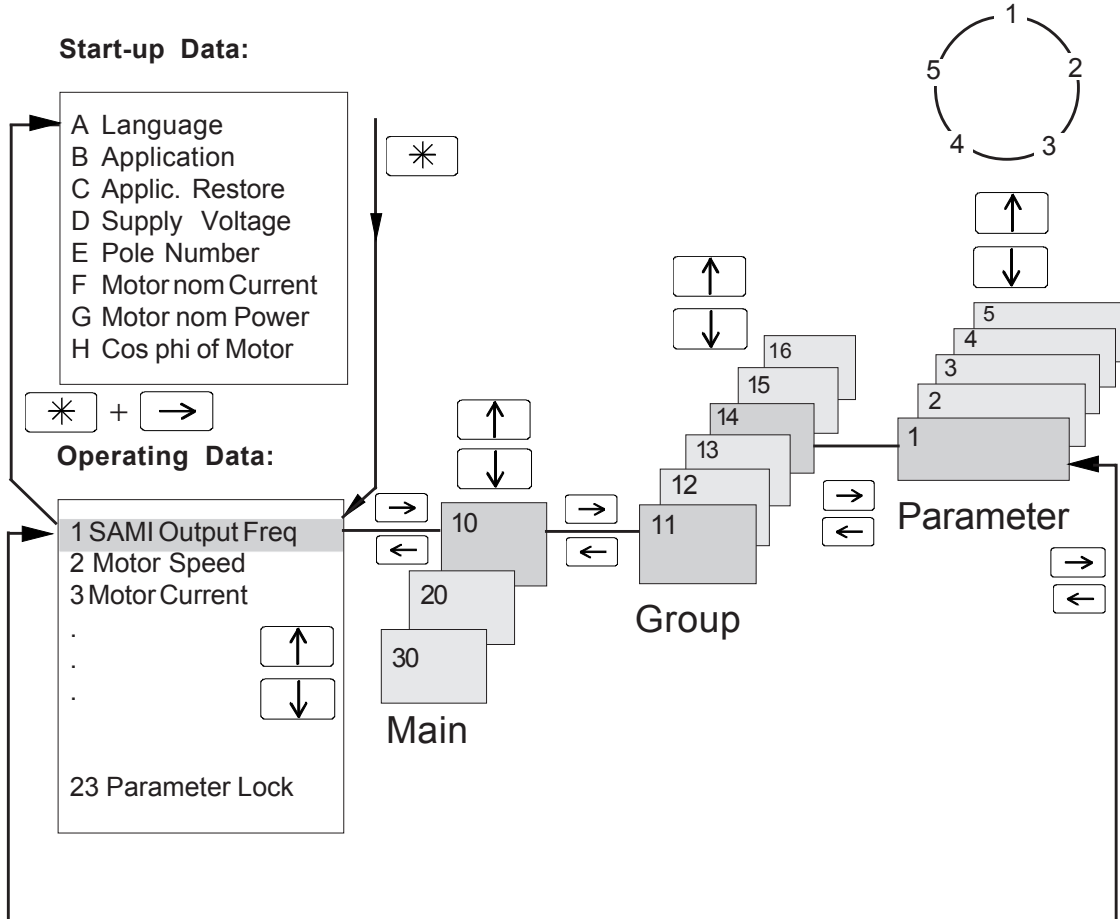

Figure 7-2. The parameters are divided into 3 Main and 19 Groups according to their function. In addition there are Operating Data parameters and Start-Up Data parameters.

Start-up Data are application and motor specific, which must be entered during commissioning.

The Operating Data display monitors values from the drive. Control place and parameter lock selection is made in this mode.

A complete table of parameters is presented on pages 35 - 38.

SAMI GS

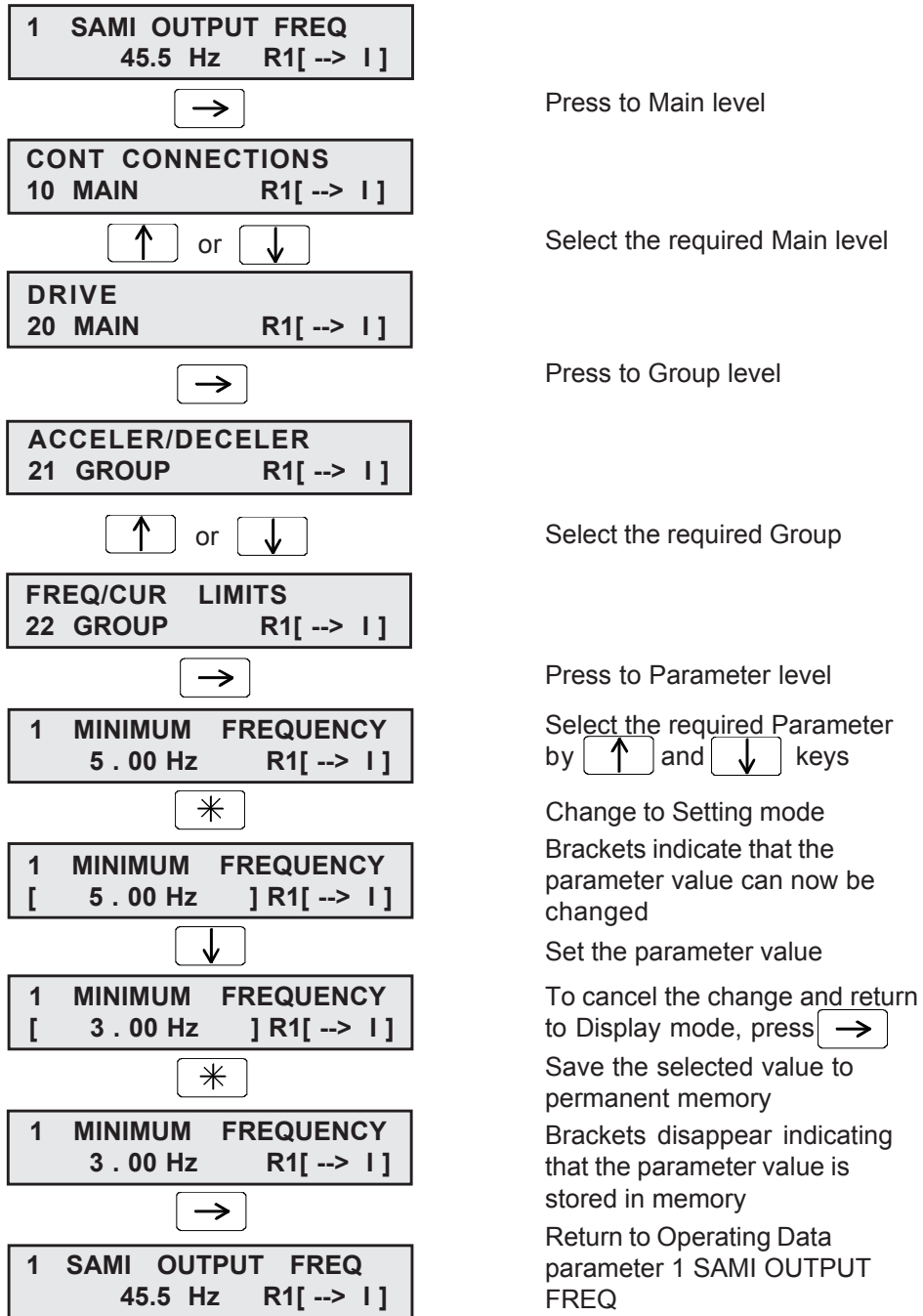

Figure 7-3. Example of control panel operation:

Let us suppose that you want to set the parameter 22.1 MINIMUM FREQUENCY to 3 Hz. The following example explains the procedure.



7.4 Adjusting Display Contrast

The contrast of the LCD can be adjusted for optimal viewing. This can be done when the display is at Main or Group level.

To adjust contrast, hold down  and press  or .

It may be necessary to adjust the display contrast if the SAMI has been installed in a location with high ambient temperatures. The factory default setting is optimum for an ambient temperature between 15 °C and 30°C.

Running data and keypad control parameters

A complete description of the parameter Groups is given in chapter 9, Drive parameters. Operating Data parameters are described here.

7.5 Operating Data

The monitored values are updated five times a second. The accuracy figures given in brackets are valid for steady state signals. Actual reference signal is shown once a second if the frequency converter is stopped. **Note!** If measured value goes beyond the range of the parameter, exclamation marks ("!!") are shown on the display.

Parameter	Range/Unit	Description
1 SAMI Output Freq	Hz	Frequency to motor
2 Motor Speed	rpm	Actual (encoder)/calculated motor speed
3 Motor Current *)	A	Motor current ($\pm 5\%$)
4 Calcd Torque/ T_n	%	Calculated motor torque, $100 = T_M (\pm 15\%)$
5 Calcd Power/ P_n	%	Calculated motor power, $100 = P_M (\pm 15\%)$
6 DC-Voltage	V	T_M and P_M correspond to the motor data given in para. E and G of Start-up group
7 SAMI Output Volt	V	Intermediate circuit DC-voltage
8 SAMI Temperature	°C	Calculated motor voltage ($\pm 5\%$)
9 Control Place	Keypad R1/ Keypad R2/External	Temperature of the heatsink Control place selection (R1 = Reference

*) This parameter indicates small current value even though the motor cables and the motor is not connected. (R2 = Reference 2)

Operating Data continued:

Parameter	Range/Unit	Description
10 Keypad Ref 1	Hz	Frequency reference from control panel
11 Keypad Ref 2	%	Controller reference from control panel
12 Ext Ref 1 or 2	Ref1/Ref2	External control place selection
13 External Ref 1	Hz	External frequency reference
14 External Ref 2	%	External controller reference
15 Appl Block Output	Hz	Controller output signal
16 Actual Value 1*)	%	Feedback signal for the PI-controller
17 Actual Value 2*)	%	Feedback signal for the PI-controller
18 Op-Hour Counter	h	Operation hour counter
19 kWh Counter	kWh	kWh counter
20 Last-Recd Fault	-	The latest fault indication (refer to p. 73)
21 Second-Recd Fault	-	The previous fault indication
22 First-Recd Fault	-	The oldest fault indication
23 Parameter Lock	Open xxx/Locked xxx	Parameter software lock (xxx code = 358)
24 Aux Motrs running**)	number	Number of running constant speed (mains connected) motors
25 Controller Output**)	%	Output value of PI regulator. Values in % of regulation range.
26 Controller deviation**)	%	Deviation of PI regulator in % of regulation range including sign (+ if ACT>REF, - if ACT<REF)
27 Act value 1 (PFC)**)	units	Unscaled actual feedback signal no.1 in units set with parameter 28.30
28 Act value 2 (PFC)**)	units	Unscaled actual feedback signal no. 2 in units set with parameter 28.30

*)These parameters are displayed only if the PI- or PFC-Control macro is selected.

***)These parameters are displayed only if the PFC-Control macro is selected.

7.6 Control

The SAMI GS can be controlled from two external control places or from the Control Panel Keypad (Fig. 7-5 on p. 30). The figure below presents the standard control signal selections.

How to set reference:

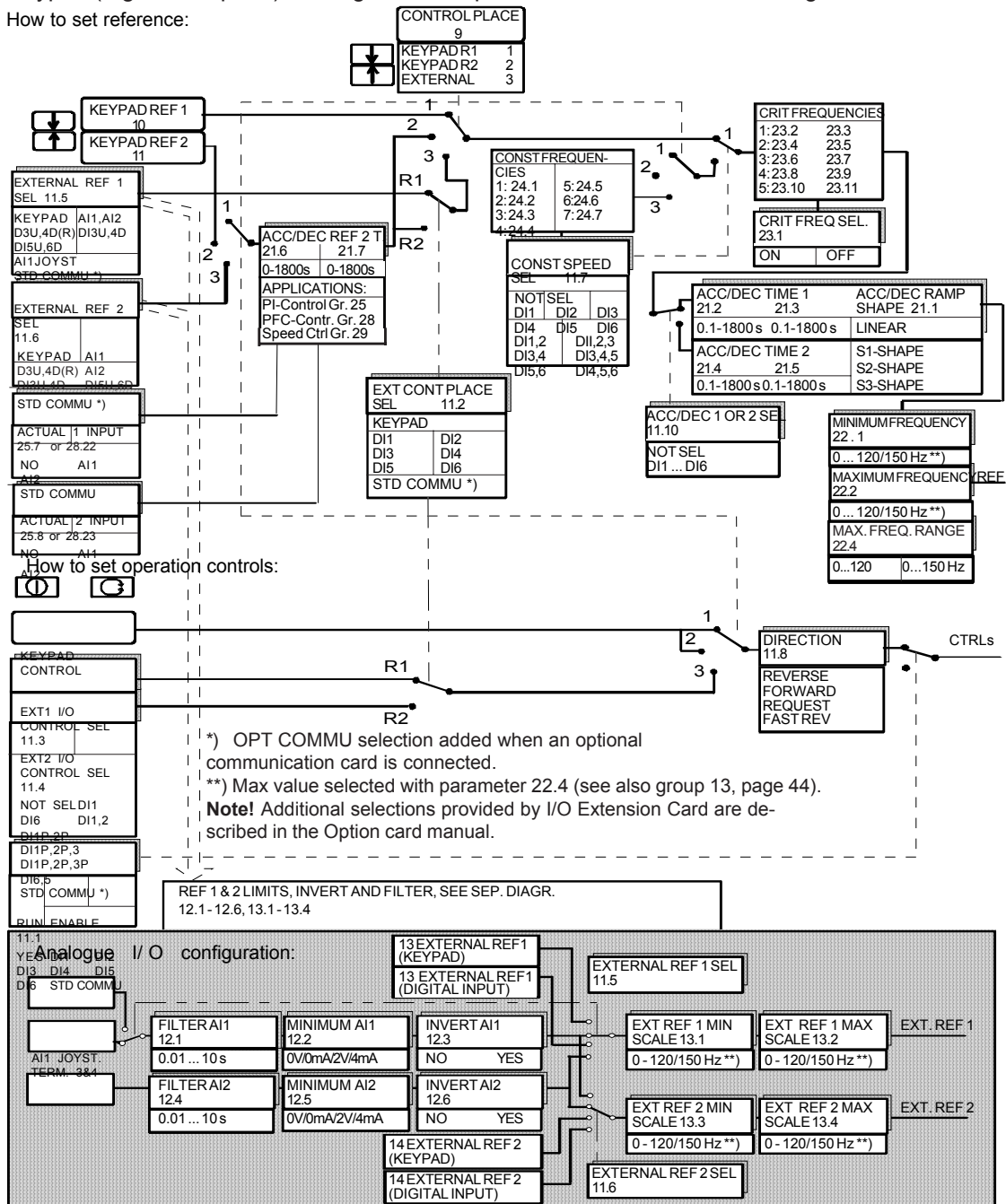

Figure 7-4. Standard control signal selections. The software switches in the diagram are set either by parameter or digital inputs, as indicated in the box at the end of the dashed line.

SAMI GS

Select Operating Data parameter 9, CONTROL PLACE, KEYPAD R1/KEYPAD R2 for keypad control (Control place is Ref 1 or Ref 2 accordingly) or EXTERNAL for external control. The valid control place is indicated on the display. [] around the direction and run indicators means keypad control and without [] means external control. In addition R1 means Ref 1 and R2 Ref 2 (Figure 7-1).

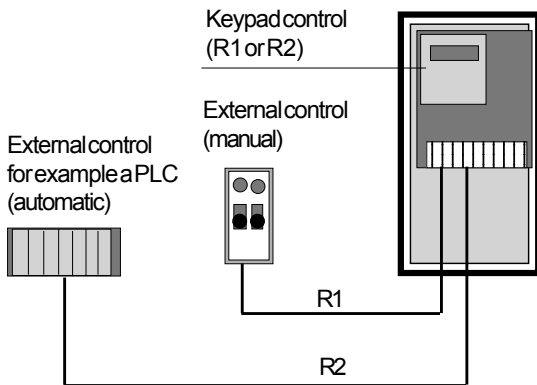

Figure 7-5. Control places.

7.7 Keypad Control

When Keypad R1 or Keypad R2 is selected from Operating Data parameter 9, the SAMI GS will operate according to the commands which are given via the Keypad.



= START/STOP button



= FORWARD/REVERSE button

Reference signal = see sections Keypad Reference 1 and Keypad Reference 2

Keypad Reference 1

Operating Data parameter 10 KEYPAD REF1 is a direct frequency reference. To set the frequency reference, select parameter 10 KEYPAD REF1, press the [*] key and use the [↑] and [↓] keys to increase

or decrease the keypad reference.

When in keypad control using reference 1, it is possible to change the keypad reference value while monitoring any of the measured values 1-8. For example, you can monitor parameter 7, SAMI OUTPUT VOLT while changing the frequency. To do this, select the measured value you prefer, press [*] key and set the reference frequency with [↑] and [↓] keys.

If the SAMI GS is running with an external reference and the CONTROL PLACE is changed to KEYPAD R1, it is possible to transfer the current value of the external reference to KEYPAD REF1.

Example: The SAMI GS is receiving a frequency reference from a transducer via X50. You want to temporarily override the external frequency reference. Select CONTROL PLACE, KEYPAD R1 and press [⏻] and [*]. The SAMI GS puts the value of the external reference into KEYPAD REF1. You may now control the drive manually by KEYPAD REF1.

If you enter Display mode by pressing [*] after selecting CONTROL PLACE, KEYPAD R1, the value of parameter KEYPAD REF1 will be the set MINIMUM FREQUENCY.

Keypad Reference 2

Keypad Reference 2 goes through an application block, where it can be manipulated. Keypad Reference 2 can be used as a controller reference and it can be given its own acceleration/deceleration ramps (Refer to parameters 21.6 and 21.7 on page 51).

7.8 External Control

The external control place (Ref1/Ref2) is selected with digital input 1-6 or Operating Data parameter 12, EXT REF 1 OR 2 depending on the setting of parameter 11.2 EXT CONT PLACE SEL (Keypad, DI1-DI6).

External Reference 1

External frequency reference from control place R1. The signal source selection is made with parameter 11.5, EXTERNAL REF1 SEL. Refer to page 39 for available options.

External Reference 2

External Reference 2 goes through an application block, where it can be manipulated as Keypad Reference 2. The signal source selection is made with parameter 11.6, EXTERNAL REF2 SEL. Refer to page 39 for available options.

7.9 Parameter Lock

Parameter Lock prevents unauthorised persons altering the parameters. If parameter lock is active (Operating Data parameter 23 or digital input 1-6/parameter 11.11), it is not possible to change to Setting mode (control place can still be selected with para. 9).

The SAMI GS Parameter Lock can be controlled with the Keypad (Operating Data para. 23) or a digital input. The control place is selected with parameter 11.11 PARAM. LOCK SEL (Keypad, DI1-DI6). To activate the Parameter Lock, set Operating Data parameter 23 PARAMETER LOCK to LOCKED xxx (control place = Keypad) or activate the selected digital input (control place = DI).

The Parameter Lock control place is indicated in Operating Data parameter 23 PARAMETER LOCK. Characters xxx after the parameter value (OPEN xxx, LOCKED xxx) indicate that the current control place is Keypad.

To open the Parameter Lock, you must enter the correct combination. The combination for all SAMI GS units is 358. When viewing PARAMETER LOCK, indent to setting mode and set the 358 code. Press  to open the Parameter Lock.

8 Commissioning

8.1 Safety Precautions

Before commissioning, observe the following warnings.

The circuits in the Converter Module are at mains potential when the SAMI GS is connected to the mains. This voltage is extremely dangerous and can cause severe injury and even death if you come in contact with it.

When the supply voltage is disconnected, it will take about 5 minutes before the capacitors in the intermediate DC circuit are discharged to a safe voltage.

To ensure that the voltage level is safe, always measure the voltage between the brake terminals Udc+ and Udc- (see Figure 5-1 on page 20).

The circuits in the Control Unit are isolated from the main circuit, BUT CAN HAVE DANGEROUS VOLTAGES present at the relay contacts, X50 terminals 21-29, if they are switching mains voltage. Always check for high voltage at X50 terminals 21-29 (and at relay contacts of Option Cards) before working on the Control Unit.



When SAMI is connected to the mains, the motor terminals U2, V2 and W2 (and the brake terminals Udc+, Udc- and BR) are live even when the motor is not running.

DO NOT WORK ON THE FREQUENCY CONVERTER WHEN POWER IS APPLIED!

8.2 Sequence of Operations

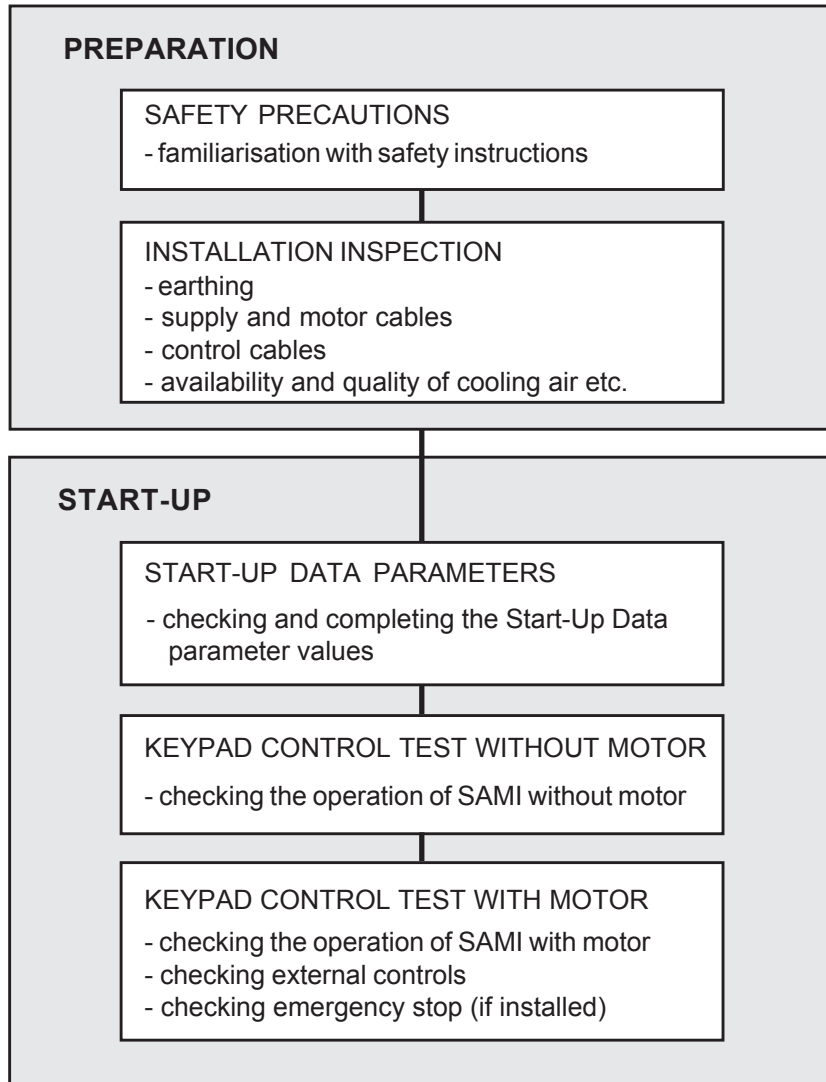

Figure 8-1. The sequence of operations during commissioning. More detailed information describing the necessary functions in each block is given on pages 31 - 34.

8.3 Installation Inspection

Inspect the mechanical and electrical installation of the SAMI for compliance with the prevailing electrical installation regulations and the installation instructions contained in Section 4 - 6.

Note! Ensure the motor cable is disconnected before proceeding with the Keypad control test without motor (see page 34).

Ensure the following is inspected:

- protective earthing of the SAMI and the motor
- supply and motor cables (cable cross section, fuse protection, connections, cable screen earthing; see Table 5-1 and Figure 5-1 on pages 19 and 20)
- control cables (connections, cable screen earthing, location as far as possible from the power cables); for analogue input signal selection, see Figure 6-1
- quantity and quality of cooling air for the SAMI, see section 4.1
- Check that the on/off switches of all external controls (if existing) are set to off. Make sure that starting of the motor is allowed.
- Check that the voltages of internal transformer(s) correspond to the mains voltage.
- Connect the SAMI to the mains. Check by measurement that the voltage between U1-V1, U1-W1 and V1-W1 is $U_N \pm 10\%$.

8.4 Start-Up Data Parameters

Power up the SAMI. The display shows Operating Data parameter 1, SAMI OUTPUT FREQ at the first power up. Before proceeding with the commissioning, check and complete the Start-Up Data parameter values.

While viewing para. 1, SAMI OUTPUT FREQ, first press and hold, then press . The display shows parameter

A LANGUAGE in Setting mode.

A LANGUAGE

Select the preferred language. Press to confirm the selection and move to the next parameter.

B APPLICATIONS

Refer to the Application Macro Manual for complete information concerning the Application Macros. Select the Application Macro which best corresponds to your application. The parameter settings in each Macro can be set separately to adapt to your application. Press to move to the next parameter.

C APPLIC. RESTORE

This parameter allows you to retrieve the factory settings of the selected Application Macro. Press to move to the next parameter.

D SUPPLY VOLTAGE (U_N)

E POLE NUMBER

F MOTOR NOM CURRENT (I_M)

G MOTOR NOM POWER (P_M)

H COS PHI OF MOTOR

Set the correct values corresponding to the supply network and the driven motor. Press to move to the next parameter.



When you have scrolled through all the parameters A-H and pressed after setting the parameter H COS PHI OF MOTOR, the display shows again Operating Data parameter 1 SAMI OUTPUT FREQ.

Note! If the nominal current of the motor is different from the nominal current of the SAMI GS, set parameter 27.3, MOTOR POWER accordingly. (Refer to page 59).

8.5 Checking Selected Application Macro Parameters

Selected macro parameters have default settings which suit most purposes. The parameters which are not included in the Application Macro retain the factory settings. If it is necessary to adjust the parameter values, refer to the instructions in Sections 7 and 9. Use the parameter list in the Application Macro Manual (or Table on pages 35 - 38) to record your settings. Only selected macro parameters will be displayed (e.g. Parameter group 25 for PI Control and group 28 for PFC Control).

8.6 Keypad Control Test without Motor

1. If the motor is connected to the SAMI, disconnect it (after first making sure that the SAMI is disconnected from the mains).
2. Connect the SAMI to the mains and switch power on.
3. Set the DIRECTION (para. 11.8) to REQUEST.
4. Select Operating Data, 9 CONTROL PLACE, KEYPAD R1 (see Section 7, Control and Parameter Logic).
5. Return to para. 1 SAMI OUTPUT FREQ.
6. Give a start command by pushing . The run status indicator on the display should show "I".
7. Use  key to change the rotation direction. The rotation direction display should change accordingly.
8. Change to the Setting Mode and control the reference frequency. Return to Display mode by pressing .
9. Check the Operating Data parameter values.

Parameter 7, SAMI OUTPUT VOLTAGE should increase with the frequency. Programmed maximum voltage is reached at the field weakening frequency (default is 50

Hz).

10. If everything is operating normally, turn off SAMI and disconnect it from the mains.



Note! Wait at least 5 minutes after the display readout has disappeared before taking any further action within the SAMI.

(For fault tracing information, refer to Section 10 page 73)

8.7 Keypad Control Test with Motor

1. Connect the motor to the SAMI (after first making sure that the SAMI is disconnected from the mains).
2. Connect the SAMI to the mains and switch power on.
3. Select Operating Data, 9 CONTROL PLACE, KEYPAD R1 (see Section 7, Control and Parameter Logic).
4. Select KEYPAD REF 1. Choose 0.5 Hz.



Warning! If rotation direction is critical, do not increase speed reference more than necessary after start to make sure the motor is running in the right direction. If the rotation direction is not correct swap 2 of the motor cable connections.

5. Give a start command by pushing .
6. Check the Operating Data parameter values for normal operation.
7. Change to Setting Mode and increase the reference. Verify that the frequency is increasing. Increase the frequency to 50 Hz. Return to Display Mode.
8. If external controls, analogue outputs, relay outputs, PI-controller or other control equipment is used in the application, check that they operate correctly.

SAMI GS

8.8 Drive Parameters and Their Factory Settings (Factory Macro).

MAIN	GROUP	PARAMETER	DEFAULT	CUSTOMER SETTING
Operating Data (not a Main)	Operating Data	9 Control Place	Keypad R1	
		12 Ext Ref 1 or 2	Ref1	
		23 Parameter Lock	Open xxx	
	Start-Up Data	A Language	English	
		B Application	Factory	
		C Applic. Restore	No	
		D Supply Voltage	400/500/600 V ¹⁾	
		E Pole Number	4	
		F Motor Nom Current (I_M)	I_N of SAMI	
		G Motor Nom Power (P_M)	P_N of SAMI	
H Cos phi of Motor	0.83			
10 Cont Connections	11 Dig/Analog Input Sel	1 Run Enable	Yes	
		2 Ext Cont Place Sel	Keypad	
		3 Ext 1 I/O Cont Sel	DI1,2	
		4 Ext 2 I/O Cont Sel	Not Sel	
		5 External Ref1 Sel	AI1	
		6 External Ref2 Sel	Keypad	
		7 Const Speed Sel	DI3,4	
		8 Direction	Request	
		9 Fault Reset Sel	Not Sel	
		10 Acc/Dec 1 or 2 Sel		
		11 Parameter Lock Sel	Keypad	
	12 Analogue Inputs	1 Filter AI1	0.1s	
		2 Minimum AI1	0V/0mA	
		3 Invert AI1	No	
		4 Filter AI2	0.1s	
		5 Minimum AI2	0V/0mA	
		6 Invert AI2	No	
	13 Ref Value Scaling	1 Ext Ref1 Min Scale	0 Hz	
		2 Ext Ref1 Max Scale	50 Hz	
		3 Ext Ref2 Min Scale	0 Hz	
		4 Ext Ref2 Max Scale	50 Hz	
	14 Output Signals	1 Analogue Out 1	Out Freq	
		2 Analogue Out 2	Out Cur	
		3 Relay RO1 Out	Ready	
		4 Relay RO2 Out	Run	
		5 Relay RO3 Out	Fault	
	15 Analogue Outputs	1 Filter AO1	2 s	
		2 Minimum AO1	0 mA	
		3 Invert AO1	No	
		4 Filter AO2	2 s	
		5 Minimum AO2	0 mA	
		6 Invert AO2	No	
	16 Out Sig scaling	1 Scale AO1	100 %	
		2 Scale AO2	100 %	
	17 Ext. Communi- cation	1 SAMI ID number	0	
		2 Bit rate select	9600 bit/s	
		3 Time-out select	100.0 s	
		4 Comms. fault funct.	None	
		5 Bad message counter	(number)	
		6 Good mess counter	(number)	

¹⁾ 400 V in 400 V units, 500 V in 500 V units and 600 V in 600 V units

SAMI GS

MAIN	GROUP	PARAMETER	DEFAULT	CUSTOMER SETTING
20 Drive	21 Acceler/Deceler	1 Acc/Dec Ramp Shape	Linear	
		2 Acceler Time 1	3 s	
		3 Deceler Time 1	3 s	
		4 Acceler Time 2	60 s	
		5 Deceler Time 2	60 s	
		6 Acceler Ref2 Time	60 s	
		7 Deceler Ref2 Time	60 s	
	22 Freq/Cur Limits	1 Minimum Frequency	0 Hz	
		2 Maximum Frequency	50 Hz	
		3 Output Current	$1.5 * I_N$ [A]	
		4 Maximum Freq. range	120 Hz	
	23 Crit Frequencies	1 Crit Freq Select	Off	
		2 Crit Freq1 Low	0 Hz	
		3 Crit Freq1 High	0 Hz	
		4 Crit Freq2 Low	0 Hz	
		5 Crit Freq2 High	0 Hz	
		6 Crit Freq3 Low	0 Hz	
		7 Crit Freq3 High	0 Hz	
		8 Crit Freq4 Low	0 Hz	
		9 Crit Freq4 High	0 Hz	
		10 Crit Freq5 Low	0 Hz	
		11 Crit Freq5 High	0 Hz	
	24 Const Frequencies	1 Const Frequency 1	5 Hz	
		2 Const Frequency 2	10 Hz	
		3 Const Frequency 3	15 Hz	
		4 Const Frequency 4	20 Hz	
		5 Const Frequency 5	25 Hz	
		6 Const Frequency 6	40 Hz	
		7 Const Frequency 7	50 Hz	
	25 PI-Controller (Parameters available only if PI-Control macro has been selected)	1 PI-Cont Gain	100 %	
		2 PI-Cont I-Time	60 s	
		3 PI-Cont Min Lim	25 Hz	
		4 PI-Cont Max Lim	50 Hz	
		5 Error Value Inv	No	
		6 Actual Value Sel	Act1	
		7 Actual 1 Input	No	
		8 Actual 2 Input	No	
		9 Actual1 Min Scale	0	
		10 Actual1 Max Scale	0	
		11 Actual2 Min Scale	0	
		12 Actual2 Max Scale	0	
	26 Start/Stop	1 Start Function	Ramp	
		2 Torque Boost Cur	$1.5 * I_N$ [A]	
3 Stop Function		Coast		
4 Brake Chopper		No		
5 DC-Holding		Off		
6 DC-Hold Voltage		$0.01 * U_N$ [V]		
7 DC-Brake Voltage		$0.01 * U_N$ [V]		
8 DC-Brake Time		0 s		

SAMI GS

MAIN	GROUP	PARAMETER	DEFAULT	CUSTOMER SETTING
20 Drive	27 Motor Control	1 Switching Freq	3 kHz	Cannot be set by the user
		2 SAMI Max Out Volt	$100 \% * U_N [V]$	
		3 Motor Power	Rated	
		4 U/f Ratio	Linear	
		5 Field Weak Point	50 Hz	
		6 IR-Compensation	No	
		7 IR-Comp Voltage	$0.01 * U_N [V]$	
		8 IR-Comp Range	0 Hz	
		9 Slip Compensation	Off	
		10 Nominal Slip	4 %	
		11 O/U Volt Control	On	
	28 PFC Control (Parameters available only if PFC control macro has been selected)	1 PI-cont gain	250.0 %	
		2 PI-cont I-time	3 s	
		3 Reference step 1	0 %	
		4 Reference step 2	0 %	
		5 Reference step 3	0 %	
		6 Sleep delay	60 s	
		7 Sleep level	24 Hz	
		8 Wake-up level	35.0 %	
		9 Start freq 1	51.0 Hz	
		10 Start freq 2	51.0 Hz	
		11 Start freq 3	51.0 Hz	
		12 Low freq 1	25 Hz	
		13 Low freq 2	5 Hz	
		14 Low freq 3	25 Hz	
		15 Aux mot start DLY	5 s	
		16 Aux mot stop DLY	3 s	
		17 NBR of aux motos	1	
		18 Autochang interv.	72 h	
		19 Autochange level	45.0 %	
		20 Interlocks	On	
		21 Error value inv	No	
22 Actual 1 input	AI 2			
23 Actual 2 input	No			
24 Actual value sel	ACT1			
25 ACT1 min scale	100 %			
26 ACT1 max scale	100 %			
27 ACT2 min scale	100 %			
28 ACT2 max scale	100 %			
29 Regul Bypass CTRL	No			
30 Display Unit	bar			
31 Display Unit Scale	1000			
32 NBR of Decimals	2			

SAMI GS

MAIN	GROUP	PARAMETER	DEFAULT	CUSTOMER SETTING
30 Protection	31 Supervision	1 Output Freq1 Func	No	
		2 Output Freq1 Lim	0	
		3 Output Freq2 Func	No	
		4 Output Freq2 Lim	0	
		5 Current Func	No	
		6 Current Lim	$0 * I_N$ [A]	
		7 Ref1 Func	No	
		8 Ref1 Lim	0 Hz	
		9 Ref2 Func	No	
		10 Ref2 Lim	0 %	
		11 Supervis messages	Off	
	32 Fault Function	1 Serial Fault Func	Stop	
		2 AI <2V/4mA Func	No	
		3 Mot Temp Flt Func	Warning	
		4 Motor Therm Time	see Table 9-1	
		5 Motor Load Curve	150 %	
		6 External Fan	No	
		7 Stall Func	Warning	
		8 Stall Current	$1.2 * I_N$ [A]	
		9 Stall Time/Freq	20 s/25 Hz	
		10 Underload Func	No	
		11 Underload Time	600 s	
		12 Underload Curve	1	
	33 Automatic Reset	1 Number of Trials	2	
		2 Trial Time	30 s	
		3 Overvoltage	No	
		4 Undervoltage	Yes	
		5 Overcurrent	No	
		6 AI Signal <2V/4mA	No	
	34 Information	1 Cri Prog Version		
		2 MC Prog Version		
		3 Test Date		

9 Drive Parameters

9.1 Main 10 - Control Connections

9.1.1 Group 11 - Dig/Analog Input Sel

These values can only be altered when the SAMI GS is stopped.

Parameter	Range/Unit	Description
1 Run Enable	Yes/DI1...DI6/Std Commu	Run enable input
2 Ext Cont Place Sel	Keypad/DI1...DI6/ Std Commu	External control place selection input
3 Ext 1 I/O Cont Sel	Not Sel/Digital Input(s) Keypad/Std Commu Refer to page 40	External control reference R1 start/stop and direction input
4 Ext 2 I/O Cont Sel	same values as para.11.3	External control reference R2 start/stop and direction input
5 External Ref1 Sel	Keypad/Analogue and Digital Inputs/Std Commu Refer to page 41	External reference 1 input
6 External Ref2 Sel	Keypad/Analogue and Digital Inputs/Std Commu Refer to page 41	External reference 2 input
7 Const Speed Sel	Not Sel/Digital Input(s) Refer to page 42	Constant frequency input
8 Direction	Reverse/Forward/ Request/Fast Rev	Rotation direction lock
9 Fault Reset Sel	Not Sel/DI1...DI6 On Stop/Std Commu	Fault/Warning/Supervision reset input Acceleration/Deceleration ramp selection
10 Acc/Dec 1or2 Sel	Not Sel/DI1...DI6	Parameter lock input
11 Param Lock Sel	Keypad/DI1...DI6	

1 Run Enable

This parameter selects the source of the Run Enable signal.

YES

Run Enable signal active.

DI1...DI6

To activate the Run Enable signal, the selected Digital Input must be connected to +24 V DC. If the Digital Input comes to 0 V DC, the drive will coast to stop.

STD COMMU

Run Enable signal can be activated via [RS 485 serial link](#).

2 Ext Cont Place Sel

This parameter defines how to select the external control place (EXT REF1/EXT REF2).

KEYPAD

The selection is made with Operating Data parameter 12 EXT REF 1 OR 2.

DI1...DI6

Choose a Digital Input; 0 V DC = EXT REF1 and +24 V DC = EXT REF2.

STD COMMU

Selection of external reference via serial link [RS 485](#).

3 Ext 1 I/O Cont Sel

4 Ext 2 I/O Cont Sel

This parameter selects the Digital Inputs used for Start/Stop and Reverse commands when using External Reference 1 (External Ref.2).

NOT SEL

No Digital Input selected.

DI1

0 V DC = Stop and +24 V DC = Start. (Rotation direction is fixed to Forward).

DI1,2

Start/Stop is connected to DI1 and Reverse to DI2. DI2 = 0 V DC = Forward and DI2 = +24 V DC = Reverse.

DI1P,2P

Start/Stop commands are given separately using pulse signals. Start is connected to DI 1 and is activated with +24 V DC pulse if Stop DI2 is connected to +24 V DC. During normal operation, DI2 is connected to +24 V DC. If DI2 is disconnected with a pulse, SAMI GS stops.

DI1P,2P,3

DI1 and DI2 as previously. Reverse is connected to DI3. 0 V DC = Forward, +24 V DC = Reverse.

DI1P,2P,3P

Start and Reverse commands are given simultaneously with two separate pulses. Stop command is given separately. Start Forward is connected to DI1 and activated with +24 V DC pulse if Stop (DI3) is connected to +24 V DC. Start Reverse is connected to DI2 and is activated as Start Forward. Stop is connected to DI3. During normal operation, DI3 is connected to +24 V DC. IF DI3 is disconnected with a pulse, SAMI GS stops.

DI6

DI6 = 0 V DC -> Stop and DI6 = +24 V DC = Start. Rotation direction is fixed to Forward.

DI6,5

Start/Stop is connected to DI6 (as previously) and Reverse to the DI5. DI5 = 0 V DC = Forward.

KEYPAD

Start/Stop is given from the Keypad.

STD COMMU

Start/Stop from RS 485 serial link.

5 External Ref1 Sel

This parameter selects the signal source of External Reference 1.

KEYPAD

Reference is given from the Keypad (Operating Data parameter 13).

AI1, AI2

0 V DC corresponds to the set EXT REF1 MIN SCALE and 10 V DC to the set EXT REF1 MAX SCALE.

AI1 JOYST.

Joystick control. 0 V DC = EXT REF1 MAX SCALE (para. 13.2) Reverse, 5 V DC = EXT REF1 MIN. SCALE (para. 13.1), 10 V DC = EXT REF1 MAX SCALE (para. 13.2) Forward.



Warning! Use only 2 - 10 V (4 - 20 mA) signal for joystick. If a 0 - 10 V signal is used, the drive will run at f_{max} to Reverse if the control

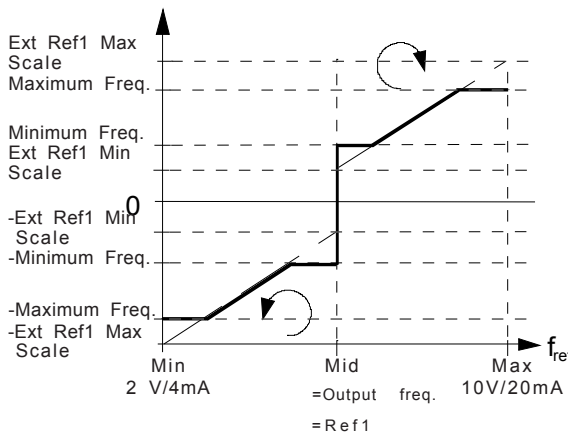

Figure 9-1. Joystick control.

signal is lost. Set para. 12.2 AI1 MINIMUM to 2V/4mA and para. 32.2 AI<2V/4mA FUNC to FAULT, and the drive will stop in case of lost control signal.

DI3U,4D(R); DI3U,4D; DI5U,6D

Motor potentiometer controlled with two Digital Inputs. U = Speed up, +24 V DC; D = Speed down, +24 V DC. If DI3U,4D(R) is selected, the frequency reference is reset to the set minimum frequency, when the SAMI GS is in STOP status or the SAMI's power is switched off. Acceleration and deceleration ramps are determined by parameters 21.4 and 21.5.

STD COMMU

External reference 1 via RS 485 serial link.

6 External Ref2 Sel

This parameter selects the signal source of External Reference 2.

KEYPAD

Reference is given from the Keypad (Operating Data parameter 14).

AI1, AI2

0 V DC corresponds to the set MINIMUM FREQUENCY and 10 V DC to the set MAXIMUM FREQUENCY.

DI3U,4D(R); DI3U,4D; DI5U,6D

Motor potentiometer controlled with two Digital Inputs. U = Speed up, +24 V DC; D = Speed down, +24 V DC. If DI3U,4D(R) is selected, then frequency reference is reset to the set minimum frequency, when the SAMI GS is in STOP status or the SAMI's power is switched off. Acceleration and deceleration ramps are determined by parameters 21.4 and 21.5.

STD COMMU

External reference via RS 485 serial link.

7 Const Speed Sel

This parameter defines which Digital Inputs are used to select Constant Speeds.

NOT SEL

No Digital Input selected.

DI1 (DI2, DI3, DI4, DI5, DI6)

Constant speed number 1 (DI1=Constant speed 1 etc.) connected to Digital Input 1. +24 V DC = Constant Speed activated.

DI1,2

Three Constant Speeds (1-3) are selected with two Digital Inputs.

DI1	DI2	
0	0	No Constant Speed
1	0	Constant Speed 1
0	1	Constant Speed 2
1	1	Constant Speed 3

DI3,4

DI5,6

Three Constant Speeds (1-3) are selected with two Digital Inputs as in DI1,2.

DI1,2,3

Seven Constant Speeds (1-7) are selected with three Digital Inputs.

DI1	DI2	DI3	
0	0	0	No Constant Speed
1	0	0	Constant Speed 1
0	1	0	Constant Speed 2
1	1	0	Constant Speed 3
0	0	1	Constant Speed 4
1	0	1	Constant Speed 5
0	1	1	Constant Speed 6
1	1	1	Constant Speed 7

DI3,4,5

DI4,5,6

Refer to DI1,2,3.

8 Direction

This parameter allows rotation direction to be fixed.

FORWARD

Direction is fixed to Forward.

REVERSE

Direction is fixed to Reverse.

REQUEST

The rotation direction is selected by Digital Inputs as defined in parameters 11.3 and 11.4 or by keypad pushbutton.

FAST REV

This function works like REQUEST. However, when parameter 26.3 STOP FUNCTION is set to COAST, the modulator starts to operate in a reverse direction immediately after Reverse is requested. This procedure results in fast reversing.

Note! Fast reverse function does not operate if the selected start function (parameter 26.1) is Flying Start (or Flying + TQB).

9 Fault Reset Sel

Fault Reset signal resets faults, warnings and supervision indications. The reset is activated by a transition from +24V to 0V.

DI1 (DI2, DI3, DI4, DI5, DI6)

Reset signal can be connected to any of the Digital Inputs 1-6.

NOT SEL

The Fault Reset function is not activated.

ON STOP

Fault is reset by Stop command (Start/Stop is selected by DI1; DI1,2 or STD COMMU as selected by parameters 11.3; 11.4).

STD COMMU

Fault resetting via RS 485 serial link.

10 Acc/Dec 1 or 2 Sel

This parameter defines which Digital Input (1-6) is used to select Acceleration/Deceleration Ramp 1 or 2.
 0 V DC = Acc/Dec Time 1
 24 V DC = Acc/Dec Time 2.

11 Param. Lock Sel

This parameter selects the control place for Parameter Lock.
 If you select KEYPAD, Parameter Lock is controlled with Operating Data parameter 23, PARAMETER LOCK. If you select a Digital Input (1-6), 0 V DC = Open and +24 V DC = Locked.

9.1.2 Group 12 - Analogue Inputs

These values can be altered with the SAMI GS running.

Parameter	Range/Unit	Description
1 Filter AI1	0.01...10s	Filter time constant for AI1
2 Minimum AI1	0 V/0 mA or 2 V/4 mA	Analogue Input signal 1 minimum value
3 Invert AI1	No/Yes	Analogue Input signal 1 inversion
4 Filter AI2	0.01...10s	Filter time constant for AI2
5 Minimum AI2	0 V/0 mA or 2 V/4 mA	Analogue Input signal 2 minimum value
6 Invert AI2	No/Yes	Analogue Input signal 2 inversion

1 Filter AI1

Filter time constant for Analogue Input 1.
 63 percent of the change of the Analogue Input value takes place within the time period given by this parameter. If you select the minimum value 0.01 s, the signal is not filtered.

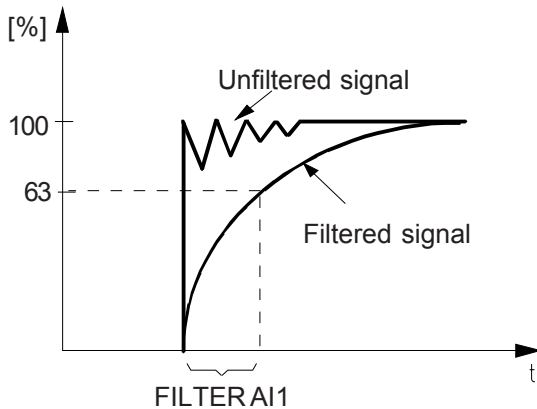

Figure 9-2. Filter time constant.

2 Minimum AI1

Analogue input signal can be set to a minimum of either 0 V/0 mA or 2 V/4 mA. The latter value provides a "living zero" function (see page 68, para. 32.2 AI<2 V/4 mA FUNC.). Refer to page 21 for selection between current and voltage input.

3 Invert AI1

If you select YES, the Analogue Input 1 signal is inverted (minimum reference corresponds to maximum output frequency). This can be used, for example to invert the feedback signal to control a reference in liquid level control.

4 Filter AI2

5 Minimum AI2

6 Invert AI2

Refer to parameters 12.1 - 12.3.

9.1.3 Group 13 - Ref Value Scaling

These values can be altered with the SAMI GS running.

Parameter	Range/Unit	Description
1 Ext Ref1 Min Scale	0...120/150Hz*)	External reference 1 minimum value Cannot be set > Ext Ref1 Max Scale
2 Ext Ref1 Max Scale	0...120/150Hz*)	External reference 1 maximum value Cannot be set < Ext Ref1 Min Scale
3 Ext Ref2 Min Scale	0...120/150Hz*)	External reference 2 minimum value Cannot be set > Ext Ref2 Max Scale
4 Ext Ref2 Max Scale	0...120/150Hz*)	External reference 2 maximum value Cannot be set < Ext Ref2 Min Scale

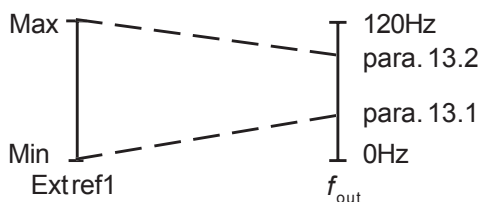

Figure 9-3. External Reference scaling.

*) Max value is set automatically according to the setting of parameter 22.4.

Note! If max./min. frequency setting is changed (para. 22.1, 22.2), the setting of parameters 13.1 and 13.2 changes accordingly. Parameter 13.3 and 13.4 are not available with Macros PI or PFC Control.

9.1.4 Group 14 - Output Signals

These values can only be altered when SAMI GS is stopped.

Parameter	Range/Unit	Description
1 Analogue Out 1	Refer to the text below for the available selections	Analogue Output 1 content
2 Analogue Out 2		Analogue Output 2 content
3 Relay RO1 Out		Relay Output 1 content
4 Relay RO2 Out		Relay Output 2 content
5 Relay RO3 Out		Relay Output 3 content

1 Analogue Out 1

This parameter allows you to select which output signal is connected to Analogue Output 1 (current signal).

= Output frequency

= Motor speed

= Output current

= Motor torque

= Motor power

= DC-link voltage

= Motor voltage

SAMI GS

Additional selections available with the PFC Control Macro.

ERROR VAL = Scaled difference of ACT and REF values

PICON OUTP = PI-regulator output

ACTUAL 1 = Unscaled actual value 1

ACTUAL 2 = Unscaled actual value 2

PICON REF = Reference of PI regulator

2 Analogue Out 2

Refer to previous parameter.

3 Relay RO1 Out

This parameter allows you to select which information is indicated with Relay Output 1. Relay Output 1 is activated (according to the setting) if:

NOT USED

No relay activity wanted.

READY

The SAMI GS is ready to function.

RUN

The motor controller is active, and the motor is running.

FAULT

Any fault occurs. See Fault History (page 73) for more details.

FAULT (-1)

Reversed function of FAULT, i.e. the relay is normally activated and it releases on a fault. See fault messages Section 10.4.

STALL FLT

Stall protection has tripped.

MHEAT FLT

Motor overheat protection has tripped.

SAMI HEATF

SAMI overheat protection has tripped. The tripping level is 85 °C.

FAULT/WARN

Relay activated if any fault or warning occurs. See messages, Section 10.4.

WARNING

Relay is activated if any warning occurs. See warning messages, Section 10.4.

SAMI HEATW

The heatsink temperature has exceeded the warning level 75 °C.

REVERSED

Reverse is selected.

EXT. CTRL

External control selected.

REF2 SEL

Reference 2 selected.

CONST FREQ

A Constant Frequency (1-7) is selected.

Uc REG LIM

Voltage regulator is activated (by Motor Control software).

FREQ1 LIM

Output frequency has exceeded the supervision limit 1 (parameter 31.2).

FREQ2 LIM

Output frequency has exceeded the supervision limit 2 (parameter 31.4).

CURLIM

Motor current has exceeded the set current limit (parameter 31.6).

REF1 LIM

Reference 1 has exceeded the set supervision limit (parameter 31.8).

REF2 LIM

Reference 2 has exceeded the set supervision limit (parameter 31.10).

4 Relay RO2 Out

This parameter allows you to select which information is indicated with Relay Output 2. Choices are identical as for para. 14.3 RELAY RO1 OUT.

5 Relay RO3 Out

This parameter allows you to select which information is indicated with Relay Output 3. Choices are identical as for para. 14.3 RELAY RO1 OUT.

Note! IF PFC Control Macro has been selected, the relevant relays for automatic exchange of motors will be reserved for this function only. The number of reserved relays depends on the number of aux. motors (para. 28.17). At least one relay will be reserved. Programming of reserved relays is not possible and the parameter value for these relays is:

PFC CTRL

9.1.5 Group 15 - Analogue Outputs

These values can be altered with the SAMI GS running.

Parameter	Range/Unit	Description
1 Filter AO1	0.01...10s	Filter time constant for AO1
2 Minimum AO1	0 mA/4 mA	Analogue Output signal 1 minimum
3 Invert AO1	No/Yes	Analogue Output signal 1 inversion
4 Filter AO2	0.01...10s	Filter time constant for AO2
5 Minimum AO2	0 mA/4 mA	Analogue Output signal 2 minimum
6 Invert AO2	No/Yes	Analogue Output signal 2 inversion

1 Filter AO1

Filter time constant for Analogue Output 1. 63 percent of the change of the Analogue Output value takes place within the time period given by this parameter. If you select the minimum value 0.01 s, the signal is not filtered (refer to Figure 9-2).

2 Minimum AO1

The minimum value of the Analogue Output signal can be set to either 0 mA or 4 mA.

3 Invert AO1

If you select YES, the Analogue Output 1 signal is inverted.

4 Filter AO2

5 Minimum AO2

6 Invert AO2

Refer to parameters 15.1 - 15.3.

9.1.6 Group 16 - Out Sig Scaling

These values can be altered with the SAMI GS running.

Parameter	Range/Unit	Description
1 Scale AO1	10...1000 %	Analogue Output signal 1 scaling factor
2 Scale AO2	10...1000 %	Analogue Output signal 2 scaling factor

1 Scale AO1, 2 Scale AO2

This parameter is the scaling factor for the Analogue Output 1 (2) signal. If you select 100 %, the nominal value of the output signal corresponds to 20 mA.

The nominal values for output signal Y are as follows:

Frequency: 50 Hz

Speed: motor speed at 50 Hz according to motor pole number

Current: nominal current of motor (I_M)

Power: nominal power of motor (P_M)

Torque: nom. power of motor $P_M /$ speed

(motor data given in Start-Up Data)

DC Voltage: DC voltage is $1.35 * \text{nominal supply voltage } (U_N, \text{ Start up Data para. D})$.

Mot. Volt.: $U_N, \text{ Start up Data para. D}$

Note! If the output voltage is set higher than U_N (para. 27.2. > 1), the scaling factor should be < 100 % to reach max voltage with 20 mA.

With PFC macro the nominal values are:

Reference value, actual value 1, actual value 2, PI-Controller output = 100 % of scaled values.

Error value: +100 % = 20 mA; -100 % = 0 mA (4 mA). This means that 0 % corresponds to 10 mA (12 mA).

If the desired value should be 20 mA, the scaling factor is calculated as follows:

$$X [\%] = 100 \% * Y / Z$$

If the desired value should be < 20 mA, the scaling factor is calculated as follows:

a) Minimum output is 0 mA

$$X [\%] = 100 \% * I_{AO} * Y / (20 \text{ mA} * Z)$$

b) Minimum output is 4 mA

$$X [\%] = 100 \% * (I_{AO} - 4 \text{ mA}) * Y / (16 \text{ mA} * Z)$$

X [%] = scaling value

I_{AO} = desired output current 0(4) - 20 mA

Y = the nominal value in units of selected output signal

Z = the desired value in units of output signal which corresponds to I_{AO}

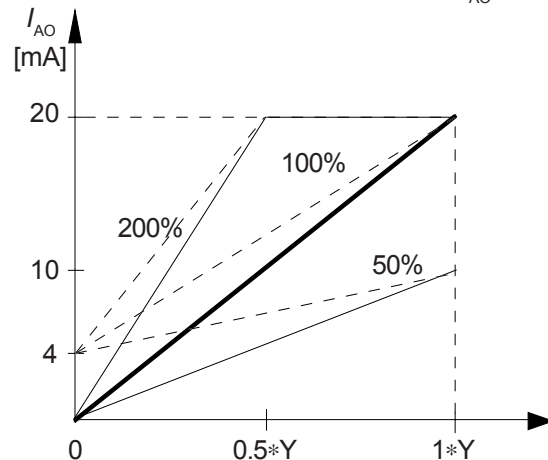

Figure 9-4. Scaling value.

9.1.7 Group 17 - Ext. Communication

These values can be altered with the SAMI GS running.

Parameter	Range/Unit	Description
1 SAMI ID Number	0 - 31	Identification of individual units connected to the serial link bus.
2 Bit Rate Select	1200, 2400, 4800, 9600 BIT/s	Speed of data transfer between the master and slave units.
3 Time-out Select	0.5 s - 100.0 s	The time which the SAMI GS waits for a response from a master before ending communication and giving a fault message.
4 Comms. fault funct	None, Fault, Fault+Stop	Type of message and operation when a fault occurs in communication between the master and a slave unit.
5 Bad messag counter	a number	Number of messages not accepted between the master and a slave unit.
6 Good mess counter	a number	Number of accepted messages between the master and a slave unit.

1 SAMI ID Number

Each SAMI GS connected to the RS 485 bus has to be identified with an ID number 1 to 31 when remote controlled. Each number can exist only once.

Number 0 disables remote control when a physical connection has been made but remote control is not allowed.

2 Bit Rate Select

The bit rate can be set according to the device used to control connected units via the serial bus.

The bit rate may also depend on settings of the possible interface converter, which has to be used if a control device does not have an RS 485 communications port.

For the optional remote control panel SAGS 700 PAN the setting is 9600 bit/s.

3 Time-out Select

Minimum value which can be set depending on the number of connected units. It is recommended that this value is set as high as possible.

If very fast information on communication faults is needed, the value can be set lower. Too short a time-out setting may cause unnecessary time-out errors.

4 Comms. fault funct

The Mode of operation depends on the setting of this parameter when a fault has occurred in the communication between the master and a slave unit:

NONE

The SAMI GS continues running with the last set parameter values and reference.

FAULT

The SAMI GS continues running and a fault message is displayed. If an output relay (RO1...RO3) is programmed as fault, this relay is activated.

FAULT+STOP

The SAMI GS stops and a fault message is displayed. If an output relay (RO1...RO3) is programmed as fault, this relay is activated.

Communication via RS 485 terminal

RS 485 serial communication is possible from an optional remote control panel SAGS 700 PAN or from a PC or a PLC.

PC and PLC applications require software utilising the protocol of the SAMI GS series. A maximum of 31 units can be connected into a bus. All units connected must have different ID number (para. 17.1).

All functions of the SAMI GS standard control panel can be utilised via the serial bus:

- Start-up
- Parameter setting
- Monitoring and supervision
- Drive commands

Maximum control bus length depends on electromagnetic disturbances, cable size and cable screening.

Recommended max. cable length is 1200 m with 0.5 mm², 50 pF/m cable and 500 m with 0.2 mm², 50 pF/m cable. Maximum common mode voltage difference between terminals GND2 or GND3 of any units may not exceed ± 7 V. The cable is connected to the screw terminal X51 on the Control Interface Card, see Figures below.

Note! The last unit connected to the serial bus without any control device must be terminated by setting plugs S3 and S4 on the Control Interface Card to the position TERM.

For further information on RS 485 serial communication please refer to SAMI GS Bus protocol manual (order code: EN 5805782-7).

Connection of Remote Control Panel SAGS 700 PAN:

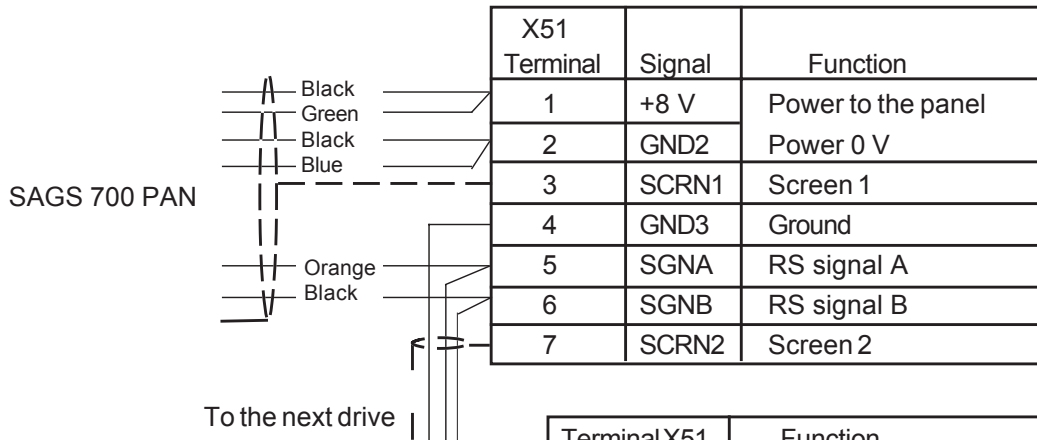

Example PC connection:

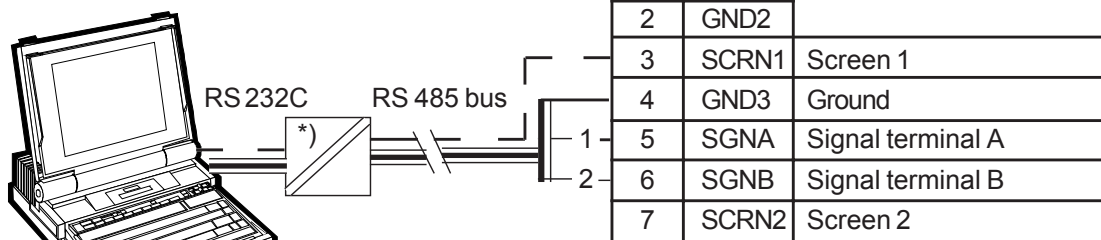

*) If the PC has an RS 232C serial communication port, a signal converter RS 232C/RS 485 is needed between the SAMI GS and the PC.

9.2 Main 20 - Drive

9.2.1 Group 21 - Acceler/Deceler

These values can be altered with the SAMI GS running.

Parameter	Range/Unit	Description
1 Acc/Dec Ramp Shape	Linear/S1...S3 Shape	Accel./Decel. ramp shape selection
2 Acceler Time 1	1...1800s	Time for $f_{\min} - f_{\max}$ acceleration ramp 1
3 Deceler Time 1	1...1800s	Time for $f_{\max} - f_{\min}$ deceleration ramp 1
4 Acceler Time 2	1...1800s	Time for $f_{\min} - f_{\max}$ acceleration ramp 2
5 Deceler Time 2	1...1800s	Time for $f_{\max} - f_{\min}$ deceleration ramp 2
6 Acceler Ref2 Time	1...1800s	Ref2 acceleration ramp time for 0 - 100 %
7 Deceler Ref2 Time	1...1800s	Ref2 deceleration ramp time for 100 - 0 %

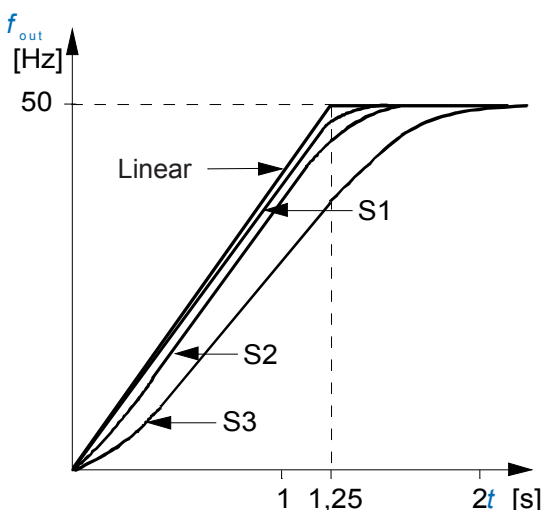

Figure 9-5. Acceleration/deceleration ramp shapes: Linear, S1, S2 and S3.

1 Acc/Dec Ramp Shape

This parameter allows you to select the shape of the acceleration/deceleration ramp. The available options are (refer to Figure 9-5):

LINEAR

Suitable for drives requiring steady acceleration/deceleration and/or slow ramps.

S1-SHAPE

Suitable for ramp times less than one second.

S2-SHAPE

Suitable for ramp times less than 1.5 seconds.

S3-SHAPE

Suitable for ramp times up to 15 seconds.

2 Acceler Time 1, 3 Deceler Time 1

4 Acceler Time 2, 5 Deceler Time 2

These times correspond to the time required for the output frequency to change from MINIMUM to MAXIMUM FREQUENCY and vice versa. Regardless of the settings, the maximum theoretical acceleration/deceleration is $120\text{Hz}/0.1\text{ s}$ (max slope = 1200 Hz/s) and the minimum $120\text{ Hz}/1800\text{ s}$ (min slope = 0.067 Hz/s). The time required for the acceleration from zero to minimum frequency depends on the ACCELER TIME (acceleration = $f_{\max} - f_{\min} / \text{acceleration time}$).

Note! The SAMI GS incorporates a bus controller that prevents overcurrent and overvoltage trips caused by too fast acceleration and deceleration for a given system (by increasing the acceleration/ deceleration settings).

If a small number is entered for the acceleration time in a system with high inertia, the acceleration time will be limited by the OUTPUT CURRENT (parameter 22.3). Conversely, if a small number is entered for deceleration time in such a system, the deceleration time will be limited by the DC link bus regulator. In some cases, the motor will take a long time to come to a stop. If a short deceleration time is critical to your application, we suggest you add a dynamic braking device to your system.

The maximum (minimum) recommended acceleration (deceleration) for the nominal size motor is 40 Hz in 1 second. If the motor rating is less than the nominal power of the SAMI GS, smaller settings can be used.

If the reference signal changes more slowly than the acceleration or deceleration time, the output frequency change will follow the reference signal. If the reference signal changes faster than the acceleration or deceleration time, the output frequency change will be limited by the parameters.

6 Acceler Ref2 Time
7 Deceler Ref2 Time

These times correspond to the time required for the reference to change from 0 to 100 % and vice versa.

9.2.2 Group 22 - Freq/Cur Limits

These values can be altered with the SAMI GS running.

Parameter	Range/Unit	Description
1 Minimum Frequency	0...120/150 Hz*)	Minimum operating frequency (f_{min})
2 Maximum Frequency	0...120/150 Hz*)	Maximum operating frequency (f_{max})
3 Output Current	0.5...2.0 * I_N [A]	Output current limit
4 Max. Freq. Range	0 - 120 Hz/0 - 150 Hz*)	Normal/Extended Range for ACS 502-506

*) Max value is set automatically according to the setting of parameter 22.4.

1 Minimum Frequency
2 Maximum Frequency

The MINIMUM FREQUENCY represents the minimum output frequency available. In a similar fashion, the MAXIMUM FREQUENCY is the maximum output frequency available (see para. 13.1 and 13.2).

3 Output Current

This setting determines the max.output current the SAMI GS will supply to the motor. If the rated current of the motor is lower than the rated current of the SAMI GS, the current limit is recommended to be set in accordance with the motor rating in standard applications.

Note! Current limitation time is not supervised. Excessive overcurrent may cause SAMI to stop the drive due to overtemperature.

Note! If a value greater than 1.5 is entered, the SAMI will automatically decrease the limit to 1.5 when the output frequency is higher than 0.74* FIELD WEAK POINT.

4 Max. freq. Range

This Parameter extends the setting range of parameter 22.1/22.2/13.1 to 13.4/23.2 to 23.11/24.1 to 24.7/28.7/28.9 to 28.14/31.2/31.4 and 31.8.

9.2.3 Group 23 - Crit Frequencies

These values can be altered with the SAMI running.

Parameter	Range/Unit	Description
1 Crit Freq Select	Off/On	Critical frequency jump over logic
2 Crit Freq 1 Low	0...120/150 Hz*)	Critical frequency 1 start
3 Crit Freq 1 High	0...120/150 Hz*)	Critical frequency 1 end
4 Crit Freq 2 Low	0...120/150 Hz*)	Critical frequency 2 start
5 Crit Freq 2 High	0...120/150 Hz*)	Critical frequency 2 end
6 Crit Freq 3 Low	0...120/150 Hz*)	Critical frequency 3 start
7 Crit Freq 3 High	0...120/150 Hz*)	Critical frequency 3 end
8 Crit Freq 4 Low	0...120/150 Hz*)	Critical frequency 4 start
9 Crit Freq 4 High	0...120/150 Hz*)	Critical frequency 4 end
10 Crit Freq 5 Low	0...120/150 Hz*)	Critical frequency 5 start
11 Crit Freq 5 High	0...120/150 Hz*)	Critical frequency 5 end

*) Max value is set automatically according to the setting of parameter 22.4.

In some systems it may be necessary to avoid some frequencies because of resonance problems. With this Group it is possible to set up five different frequency ranges the frequency converter will skip. It is not necessary that, for example, 4 CRIT FREQ 2 LOW be greater than 3 CRIT FREQ 1 HIGH, providing the LOW parameter of any one set is lower than the HIGH parameter of the same set. Sets may overlap, but the skip will be from the lower LOW value to the higher HIGH value.

The Critical Frequency settings are activated with parameter 1 CRIT FREQ SELECT (Yes).

Example: A fan system has severe vibration problems from 18 Hz to 23 Hz and from 46 Hz to 52 Hz. The speed reference is set to 60 Hz. Set the parameters as follows (set the "HIGH" value first before setting the "LOW" value):

2 CRIT FREQ 1 LOW	18 Hz
3 CRIT FREQ 1 HIGH	23 Hz
4 CRIT FREQ 2 LOW	46 Hz
5 CRIT FREQ 2 HIGH	52 Hz

If, due to e.g. bearing wear, another resonance occurs at 34 - 36 Hz, the critical frequency table can be added to as follows:

6 CRIT FREQ 3 LOW	34 Hz
7 CRIT FREQ 3 HIGH	36 Hz

Note! Scale the range to 0 Hz for those Critical Frequencies which are not used.

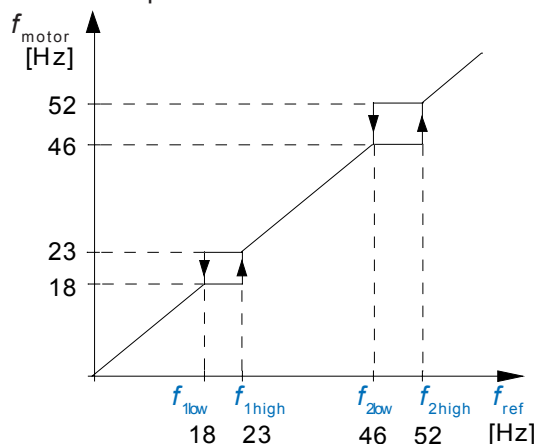

Figure 9-6. Example of Critical Frequencies settings in a fan system with vibration problems at the frequency ranges 18 Hz - 23 Hz and 46 Hz - 52 Hz.

9.2.4 Group 24 - Const Frequencies

These values can be altered with the SAMI GS running.

Parameter	Range/Unit	Description
1 Const Frequency 1	0...120/150 Hz*)	Override frequency 1
2 Const Frequency 2	0...120/150 Hz*)	Override frequency 2
3 Const Frequency 3	0...120/150 Hz*)	Override frequency 3
4 Const Frequency 4	0...120/150 Hz*)	Override frequency 4
5 Const Frequency 5	0...120/150 Hz*)	Override frequency 5
6 Const Frequency 6	0...120/150 Hz*)	Override frequency 6
7 Const Frequency 7	0...120/150 Hz*)	Override frequency 7/Jog (para. 32.1)

*) Max value is set automatically according to the setting of parameter 22.4.

Constant Frequencies override any other reference, when in External Control mode. Constant Frequencies are activated with Digital Input(s) according to parameter 11.7 CONST SPEED SEL.

Note! CONST FREQUENCY 7 is a jog frequency, which may be activated in case of serial communication fault. Refer to parameter 32.1.

9.2.5 Group 25 - PI-Controller

These values can be altered with the SAMI GS running except those marked with (O). The parameters of this group will be available only when parameter B APPLICATIONS of the START-UP DATA group has been set to PI-CONTROL, see Section 8.4.

Parameter	Range/Unit	Description
1 PI-Cont Gain	3...800 %	PI-Controller Gain selection
2 PI-Cont I-Time	0.02...320.00 s	PI-Controller I-time selection
3 PI-Cont Min Lim	0... 120/150 Hz*)	PI-Controller output freq. minimum limit
4 PI-Cont Max Lim	0... 120/150 Hz*)	PI-Controller output freq. maximum limit
5 Error Value Inv	No/Yes	PI-Controller error value inversion
6 Actual Value Sel (O)	Act1/Act1-Act2/ Act1+Act2/Act1* Act2	PI-Controller Actual signal selection
7 Actual 1 Input (O)	No/AI1/AI2/Std Commu	Actual 1 signal input selection
8 Actual 2 Input (O)	No/AI1/AI2	Actual 2 signal input selection
9 Actual 1 Min Scale	-1600.0...1600.0 %	Minimum scaling factor for act. 1 signal
10 Actual 1 Max Scale	-1600.0...1600.0 %	Maximum scaling factor for act. 1 signal
11 Actual 2 Min Scale	-1600.0...1600.0 %	Minimum scaling factor for act. 2 signal
12 Actual 2 Max Scale	-1600.0...1600.0 %	Maximum scaling factor for act. 2 signal

*) Max value is set automatically according to the setting of parameter 22.4.

1 PI-Cont Gain

This parameter defines the gain of the PI-Controller included in the Application Macros of the SAMI GS. Setting range is 3...800 %. If you select 100 %, a 10 % change in error value causes the controller output to change by 1.5 Hz.

If the parameter value is set to 3.0 %, the PI-Controller operates as an I-Controller.

2 PI-Cont I-Time

If the parameter value is set to 320.00 s, the PI-Controller operates as a P-Controller.

How to start up the PI-Controller

To start the PI-controller it is useful to measure the motor frequency and reference it to the PI-controller (Ref 2). This can be done by setting the parameter 14.1 and 14.2 accordingly.

First, the PI-CONT I-TIME is set to 320.00 s to operate with a P-Controller. The PI-CONT GAIN is set to a small value (e.g. default value 100 %). With small reference steps (1%) the response (motor frequency) is monitored. The PI-CONT-GAIN is increased until the drive ceases to be overcompensated (see Figure 9-7). This should be done within the whole speed range (approx. 100 rpm steps). Finally the response is mon-

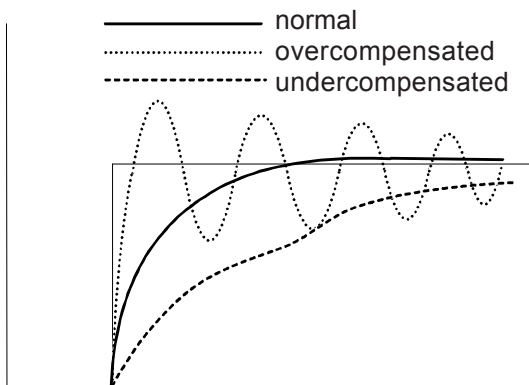

Figure 9-7. Frequency response to reference step with P-Controller.

itored with reference steps typical for the application.

For operation with PI-Controller the value for PI-CONT GAIN, determined by the operation as P-controller, is divided by 2 and put to para. 25.1. The PI-CONT I-TIME is set to a low value e.g. 10 s. The drive response (motor frequency) to small reference steps is monitored. The PI-CONT-I-TIME is increased until overshoot is observed. This should be done within the whole speed range and

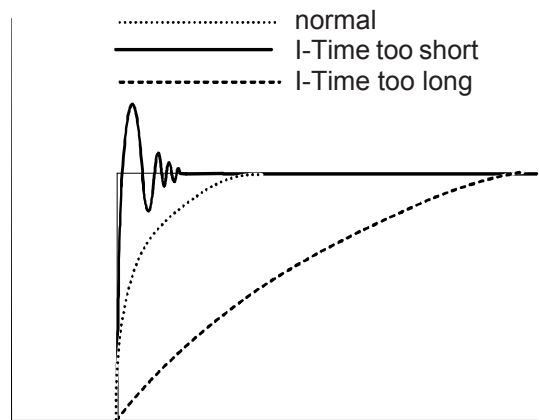

Figure 9-8. Frequency response to reference step with PI-Controller.

with reference steps suitable for this application until drive response overshooting is within acceptable range.

PI-Controller fine tuning can be done by small changes of the above determined values.

3 PI-Cont Min Lim

The minimum value of the PI-Controller frequency output. The limit can not be set less than para. 22.1 MINIMUM FREQUENCY.

4 PI-Cont Max Lim

The maximum value of the PI-Controller frequency output. The limit cannot be set greater than para. 22.2 MAXIMUM FREQUENCY.

5 Error Value Inv

This parameter allows you to invert the Error Value (and thus the operation of the PI-Controller).

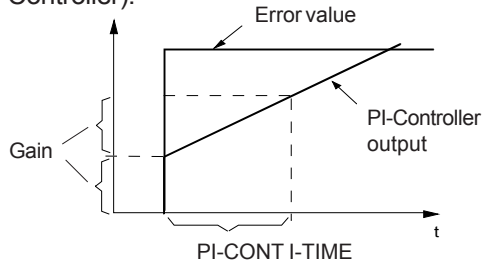

Figure 9-9. PI-Controller.

6 Actual value selection

This parameter defines how the feedback for the PI-Controller is calculated. Two analogue values (Act1 and Act2) can be subtracted, added or multiplied; also Act1 can be selected on its own.

7 Actual 1 Input, 8 Actual 2 Input

This parameter selects the input terminal for Act1 (Act2).

9 Act1 min Scale, 10 Act1 max Scale

11 Act2 min Scale, 12 Act2 max Scale

Actual value signals can be scaled to correspond to the required regulation range with the minimum and maximum value scaling parameters. Scaling values can be determined using the nomogram in Figure 9-11 and the formulae as stated below. Range of the reference value ($\Delta Y0$) and the actual value ($\Delta X0$) in units (V, mA):

$$\Delta Y0 = Y0_{max} - Y0_{min}$$

$$\Delta X0 = X0_{max} - X0_{min}$$

With the minimum and maximum values of the reference span ($Y1_{min}, Y1_{max}$) and the actual span ($X1_{min}, X1_{max}$) in units (V, mA) the values are transformed to percentages:

$$Y1'_{min} = [(Y1_{min} - Y0_{min}) / \Delta Y0] * 100 \%$$

$$Y1'_{max} = [(Y1_{max} - Y0_{min}) / \Delta Y0] * 100 \%$$

$$X1'_{min} = [(X1_{min} - X0_{min}) / \Delta X0] * 100 \%$$

$$X1'_{max} = [(X1_{max} - X0_{min}) / \Delta X0] * 100 \%$$

Span of the reference value ($\Delta Y1'$) and the actual value ($\Delta X1'$) as a percentage:

$$\Delta Y1' = Y1'_{max} - Y1'_{min}$$

$$\Delta X1' = X1'_{max} - X1'_{min}$$

Calculation of the maximum actual value (Xs'_{max}) and the minimum actual values in percentage (Xs'_{min}) of full reference scale ($Y0' = 100 \%, Y0' = 0 \%$):

ACT1(2)MAX SCALE:

$$Xs'_{max} = X1'_{max} + (100\% - Y1'_{max}) * \Delta X1' / \Delta Y1'$$

ACT1(2)MIN SCALE:

$$Xs'_{min} = X1'_{min} + (0\% - Y1'_{min}) * \Delta X1' / \Delta Y1'$$

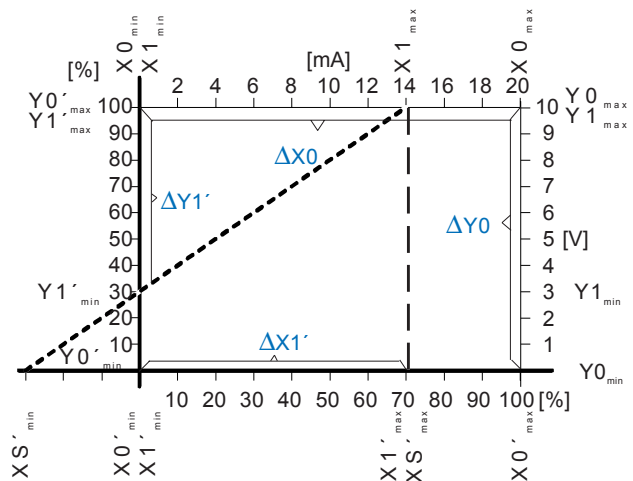

Figure 9-10. Basics of scaling factors.

Example:

The pressure of a pipe system is to be controlled between 0 and 10 bar.
 Pressure transducer for 0 to 10 bar with output span 3 to 9 V, output range 2 to 10 V.
 Reference signal is 4 to 20 mA, where 6.4 mA = 0 bar and 16mA = 10 bar.

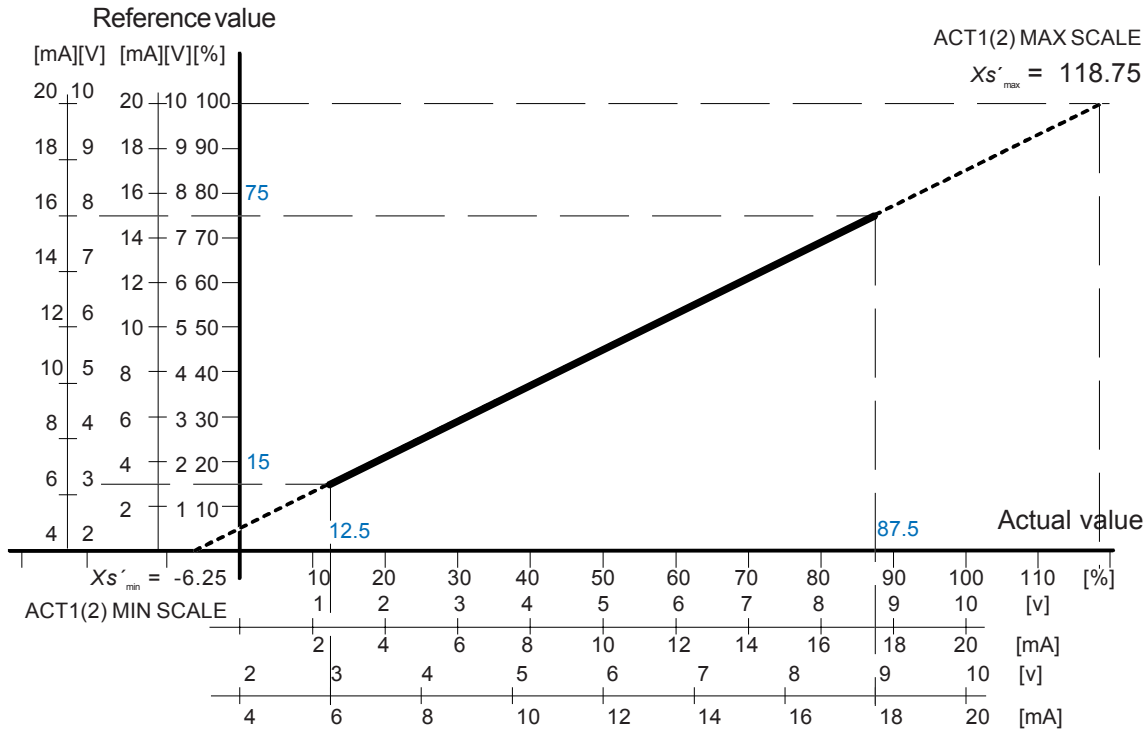

Figure 9-11. Scaling of actual value.

$$\Delta Y0 = Y0_{\max} - Y0_{\min} = 20 - 4 = 16 \text{ mA}$$

$$\Delta X0 = X0_{\max} - X0_{\min} = 10 - 2 = 8 \text{ V}$$

$$Y1'_{\min} = [(Y1'_{\min} - Y0_{\min}) / \Delta Y0] * 100 \% = [(6.4 - 4) / 16] * 100 \% = 15 \%$$

$$Y1'_{\max} = [(Y1'_{\max} - Y0_{\min}) / \Delta Y0] * 100 \% = [(16 - 4) / 16] * 100 \% = 75 \%$$

$$X1'_{\min} = [(X1'_{\min} - X0_{\min}) / \Delta X0] * 100 \% = [(3 - 2) / 8] * 100 \% = 12.5 \%$$

$$X1'_{\max} = [(X1'_{\max} - X0_{\min}) / \Delta X0] * 100 \% = [(9 - 2) / 8] * 100 \% = 87.5 \%$$

$$\Delta Y1' = Y1'_{\max} - Y1'_{\min} = 75 - 15 = 60 \%$$

$$\Delta X1' = X1'_{\max} - X1'_{\min} = 87.5 - 12.5 = 75 \%$$

$$Xs'_{\max} = X1'_{\max} + (100\% - Y1'_{\max}) * \Delta X1' / \Delta Y1' = 87.5 + (100 - 75) * 75 / 60 = 118.75 \%$$

$$Xs'_{\min} = X1'_{\min} + (0\% - Y1'_{\min}) * \Delta X1' / \Delta Y1' = 12.5 + (0 - 15) * 75 / 60 = -6.25 \%$$

$$\text{ACT1(2) MAX SCALE} = 118.8 \%$$

$$\text{ACT1(2) MIN SCALE} = -6.3 \%$$

The Result has been drawn in Figure 9-11 above.

9.2.6 Group 26 - Start/Stop

These values can only be altered when the SAMI GS is stopped except those marked with (I).

Parameter	Range/Unit	Description
1 StartFunction	Ramp/Flying/Torq Boost/Flying+TQB	Conditions during motor acceleration
2 Torque Boost Cur	0.5...2.0 * I_N [A]	Torque Boost current level selection
3 Stop Function (I)	Coast/Ramp/DC-Brake	Conditions during motor deceleration
4 Brake Chopper (I)	No/Yes	Dynamic Braking Device activation
5 DC Holding	Off/On	Enable DC Holding
6 DC-Hold Voltage	0.01...0.1 * U_N [V]	Voltage set for DC Holding
7 DC-Brake Voltage	0.01...0.1 * U_N [V]	Voltage set for DC injection braking
8 DC-Brake Time	0...250s	Duration of DC injection braking

1 Start Function

This parameter determines how the SAMI will start.

RAMP

Ramp acceleration as set in Group 21.

FLYING

Use this setting to start the motor if it is already rotating, such as in a fan drive. The drive will start smoothly at the present frequency instead of starting at 0 Hz. Selecting FLYING ensures the drive will ride through short interruptions of the mains supply.

Note! Flying start searches for the running speed by applying a small torque to the load at the MAXIMUM FREQUENCY and decreasing the output frequency until the load speed is found. If the motor is not coupled to a load or the load has low inertia, the shaft speed will follow this search program. Flying start does not work properly if several motors are connected to the SAMIGS.

TORQ BOOST

Automatic start current boost, which may be necessary in drives with high starting torque. Allows using start current higher than the limit set with para. 22.3. Automatic torque boost is active only from 0 Hz to 20 Hz or until the reference speed is reached. Torque boost is not activated if the output frequency falls below 20 Hz while running.

Torque boost is only active when IR COMPENSATION is activated. Torque boost voltage is determined by IR COMP VOLTAGE.

See also IR COMPENSATION in Group 27.

FLYING + TQB

Both Flying Start and Torque Boost functions are active.

2 Torque Boost Cur

The current level used in Torque boost is set by this parameter. Keep the boost current as low as possible for the application.

3 Stop Function

This parameter determines how the SAMI will stop the drive.

COAST

The frequency converter ceases to supply voltage and the motor coasts to a stop.

RAMP

Ramp deceleration as set in Group 21.



Note! If the drive is stopped by the RUN ENABLE signal, the SAMI GS will stop by coasting regardless of the STOP FUNCTION setting.

DC BRAKE

DC injection braking stops the motor by applying DC-voltage to the stator windings. By using DC braking, the motor can be stopped in the shortest possible time, without the use of a dynamic braking device.

4 Brake Chopper

If a dynamic braking device is used, the braking torque can be increased by setting this parameter to YES.

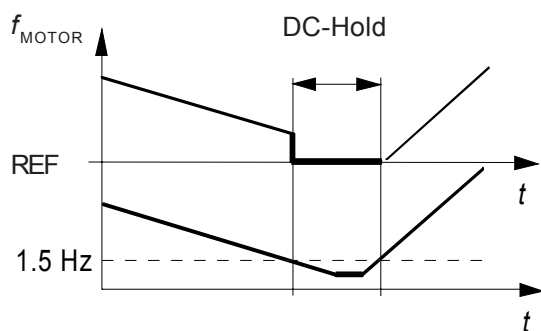

Figure 9-12 DC Holding.

5 DC Holding

If this parameter is set to YES, the DC HOLDING feature is enabled.

When both reference and output frequencies drop below 1.5 Hz, the frequency converter will stop generating rotating waveforms and inject a DC-voltage to the motor. The voltage value is set with the DC-HOLD VOLTAGE. When the reference frequency goes above 1.5 Hz, the DC-voltage will be removed and the frequency converter resumes normal operation.

DC Holding has no effect when the START signal is deactivated.

Note! Injecting DC voltage into the motor may cause motor overheating. In applications where long DC-Holding times are required, ensure the DC-HOLD VOLTAGE is set at a low value, avoiding motor overheating due to high motor current. During long DC-Hold periods the DC Hold function cannot prevent the motor shaft rotating, when a constant load is applied to the motor.

7 DC-Brake Voltage

When the stop function (para. 26.3) is set to DC BRAKE, this parameter sets the DC-voltage injected into the motor. The factory setting is suitable for a nominal size motor. If braking is too effective, decrease this value. If braking is not sufficient, increase this value.

8 DC-Brake Time

When the stop function is set to DC BRAKE, this parameter sets the DC injection time in seconds. If the braking time is too short, the drive stops by coasting once the DC-BRAKE TIME has elapsed.

9.2.7 Group 27 - Motor Control

These values can only be altered when the SAMI GS is stopped, except those marked with (I).

Parameter	Range/Unit	Description
1 Switching Freq	-	Modulator frequency
2 SAMI Max Out Volt	0.15...1.05* U_N [V]	Maximum motor voltage selection
3 Motor Power	Rated/<Rated/>Rated	$I_{N,motor}/I_{N,SAMI}$ ratio for Motor Controller
4 U/f Ratio	Linear/Squared/ Automatic	Voltage to frequency relationship in region below Field Weakening Point
5 Field Weak Point	30...180Hz	Threshold for nominal voltage
6 IR Compensation	No/Manual/Automatic	Low speed torque boost function
7 IR-Comp Voltage	0.01...0.15* U_N [V]	Voltage level in manual IR Compensation
8 IR-Comp Range	0...FWP [Hz]	Zero point in manual IR Compensation
9 Slip Compensation (I)	Off/On	Automatic slip reduction
10 Nominal Slip (I)	0.1...10%	Nominal slip of the motor
11 O/U Volt Control (I)	Off/On	Over-/Undervoltage Controller

1 Switching Freq

This parameter can not be altered by the user in ACS 502 ... ACS 506. The switching frequency of these units is 3 kHz maximum.

2 SAMI Max Out Volt

This parameter sets the maximum output voltage (fundamental) of the SAMI.

3 Motor Power

To ensure accurate operation of the Motor Control Card, it is important to indicate whether the nominal current of the motor is the same (RATED \pm 20 %), lower (< RATED) or higher (> RATED) than the nominal current of the SAMI.

4 U/f Ratio

LINEAR

The voltage of the motor changes linearly with frequency in the constant flux area. Linear U/f ratio is normally used where the torque characteristics of the load is linear

with the speed (refer to Figure 9-13).

SQUARED

The voltage of the motor is maintained in the constant flux area less than in the case of Linear U/f. The motor is undermagnetised so noise and the motor losses are reduced. Squared U/f ratio is normally used in applications where the load torque characteristic is proportional to the square of the speed, such as centrifugal pump and fan drives (refer to Figure 9-13).

AUTOMATIC

The motor voltage is automatically controlled to minimise motor losses and noise. This setting is suitable for a drive which has a slowly changing load torque and a motor that operates mainly below nominal load.

Note! If SQUARED or AUTOMATIC is selected, then para. 27.6 IR COMPENSATION should not be set to AUTOMATIC.

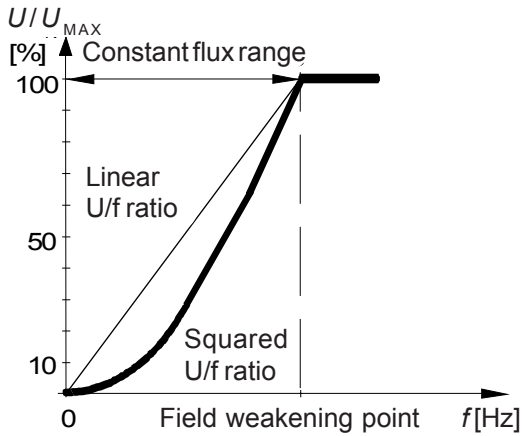

Figure 9-13. The voltage to frequency ratio in the frequency range 0 Hz to the field weakening point can be set to either LINEAR, SQUARED or AUTOMATIC.

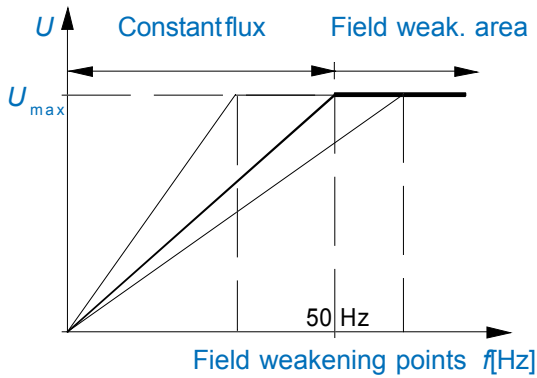

Figure 9-14. Field weakening point.

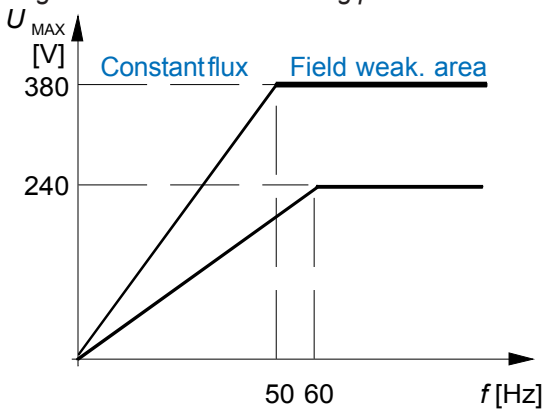

Figure 9-15. By adjusting the field weakening point and SAMI MAX OUT VOLT, motors other than those of rated voltage can be used.

5 Field Weak Point

The Field Weakening Point is the frequency at which the output voltage reaches the maximum motor voltage (para. 27.2). Above this frequency, the voltage remains at the set maximum value (U_{MAX}). Also see Figure 9-15.

6 IR Compensation

This parameter allows extra torque at speeds between 0.1 Hz and the set field weakening point. The parameter differs from the TORQ BOOST option of the START FUNCTION in that it is always valid in the above mentioned speed range.

No compensation wanted.

The compensation voltage and range are given by the user (parameters 7 and 8 in this Group).

The IR-Compensation voltage is automatically controlled as a function of effective motor current. This setting is suitable when the need for IR Compensation changes and manual optimisation of the Compensation voltage is difficult.

Note! If AUTOMATIC is selected, then LINEAR should be selected in para. 27.4 U/F RATIO.

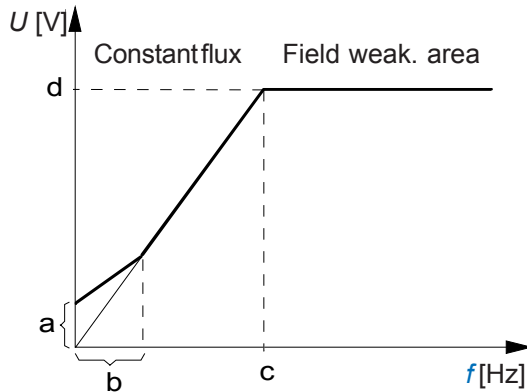

Figure 9-16. IR COMPENSATION is implemented by applying extra voltage to the motor.

a=IR-COMP VOLTAGE
b=IR-COMP RANGE
c=FIELD WEAKENING POINT
d=SAMI MAX OUT VOLT

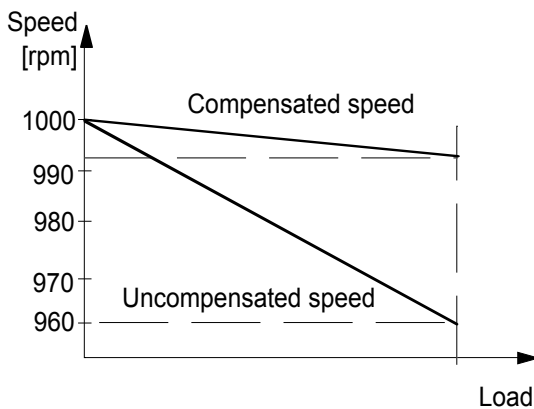

Figure 9-17. Slip compensation reduces slip under load (Example: 6-pole motor).

7 IR-Comp Voltage

The compensation voltage level in MANUAL IR COMPENSATION. Keep the boost voltage as low as possible for the application, as the motor will overheat rapidly or an overcurrent fault may occur when a high level of compensation is applied.

Small motors can take higher compensation than larger motors because the winding resistance is higher. If the load torque is high, use just enough IR-compensation to drive

the load.

8 IR-Comp Range

This parameter defines the frequency at which the Manual IR COMPENSATION reduces to zero. The compensation voltage reduces linearly with increasing frequency.

9 Slip Compensation

A squirrel-cage motor will slip under load. This slip can be compensated for by increasing the frequency as the current increases. By setting this parameter to ON, the slip will be reduced to approximately 10% of the original value. If you require exceptionally precise speed control, you may want to use tachometer feed-back control. Contact your local SAMI representative for more information.

10 Nominal Slip

For the precise operation of the Slip Compensation function, it is necessary for the SAMI to know the nominal slip of the motor. Nominal slip is given as percentage of the synchronous speed.

Nominal slip of the motor s_N [%] can be derived from synchronous speed n_s and nominal speed n_N :

$$s_N = 100\% * (n_s - n_N) / n_s$$

11 O/U Volt Control

This parameter allows you to turn off the Over-/Undervoltage Controller. This may be useful for example, if the supply network voltage varies more than $\pm 10\%$ and the application will not tolerate the O/U Controller controlling the output frequency in accordance with the supply voltage. (An under-/overvoltage trip may occur, instead).

Note! If you set the controller to ON, the internal logic of the SAMI GS also prevents starting at a high line voltage condition. See section 10.5.

SAMI GS

9.2.8 Group 28 - PFC Control

These values can be altered with the SAMI GS running except those marked with (O). The Parameters of this group will be available only when parameter B APPLICATIONS of the START-UP DATA group has been set to PFC CTRL, see Section 8.4.

Parameter	Range/Unit	Description
1 PI-Cont Gain	3 - 800.0 %	PI-Controller Gain selection
2 PI-Cont I-Time	0.1 - 320 s	PI-Controller I-time selection
3 Reference Step 1	0 - 100.0 %	Reference step when the first aux. motor is started (in % of actual value)
4 Reference Step 2	0 - 100.0 %	Reference step when the second aux. motor is started (in % of actual value)
5 Reference Step 3	0 - 100.0 %	Reference step when the third aux. motor is started (in % of actual value)
6 Sleep Delay	0 - 3600 s	Delay time for switch off with sleep function
7 Sleep Level	0 - 120/150 Hz *)	Frequency value to stop SAMI GS with sleep function
8 Wake Up Level	0 - 100.0 %	Actual value for restarting when sleep function is active (in % of actual value)
9 Start Freq 1	0 - 120/150 Hz *)	Output frequency at which the first aux. motor will start. The start frequency has a fixed 1 Hz hysteresis.
10 Start Freq 2	0 - 120/150 Hz *)	Output frequency at which the second aux. motor will start. The start frequency has a fixed 1 Hz hysteresis.
11 Start Freq 3	0 - 120/150 Hz *)	Output frequency at which the third aux. motor will start. The start frequency has a fixed 1 Hz hysteresis.
12 Low Freq 1	0 - 120/150 Hz *)	Frequency level for stopping the first aux. motor
13 Low Freq 2	0 - 120/150 Hz *)	Frequency level for stopping the second aux. motor
14 Low Freq 3	0 - 120/150 Hz *)	Frequency level for stopping the third aux. motor
15 Aux Mot Start DLY	0 - 3600 s	Start delay for the auxiliary motors
16 Aux Mot Stop DLY	0 - 3600 s	Stop delay for the auxiliary motors
17 NBR of Aux Motors	0 - 3	Number of auxiliary motors
18 Autochange Interv.	0 min - 168 h	Elapsed time for automatic exchange of connected motors

SAMI GS

Parameter	Range/Unit	Description
19 Autochange Level(O)	0 - 100.0 %	Actual value level for automatic exchange of the connected aux. motors
20 Interlocks (O)	On/Off	Enables/disables the interlocking function of aux. motors
21 Error Value Inv (O)	No/Yes	Parameter determines if error signal of PI-Controller is inverted or not
22 Actual 1 Input (O)	No/AI1-AI4/ Std Commu	Actual 1 signal input selection
23 Actual 2 Input (O)	No/AI1-AI4	Actual 2 signal input selection
24 Actual Value Sel(O)	f(ACT1, ACT2)	PFC Controller actual value selection
25 ACT1 Min Scale	-1600%...+1600%	Minimum scaling factor for actual 1 signal
26 ACT1 Max Scale	-1600%...+1600%	Maximum scaling factor for actual 1 signal
27 ACT2 Min Scale	-1600%...+1600%	Minimum scaling factor for actual 2 signal
28 ACT2 Max Scale	-1600%...+1600%	Maximum scaling factor for actual 2 signal
29 Regul Bypass Ctrl	No/Yes	Bypass selection of the PI-Controller
30 Display Unit	No/[Unit]	Selection of unit for ACT1 and ACT2
31 Displ Unit Scale	0 - 50000	Scaling factor for display unit
32 NBR of Decimals	0 - 5	Number of decimal digits of the displayed actual values.

*) Max value is automatically set according to the setting of parameter 22.4.

1 PI-Cont Gain,

2 PI-Cont I-Time

See description PI-Control Section 9.2.5.

3 Reference Step 1,

4 Reference Step 2,

5 Reference Step 3

Reference value increase after start of the first (second, third) aux. motor, e.g. in pump applications with two (or more) pumps, the reference value of the regulated pump can be increased with this parameter to correspond to the increased system pressure.

6 Sleep Delay

If the output frequency remains below the sleep level frequency (parameter 28.7) longer than the sleep delay set with this parameter, the SAMI GS is stopped automatically. If the sleep delay is set to 0 s, the sleep function is disabled.

7 Sleep Level

If the output frequency remains below the frequency set with this parameter longer than the sleep delay (parameter 28.6) the SAMI GS stops automatically. The PFC Function supervises actual value changes and re-starts the SAMI GS when the wake-up level (para. 28.8) is exceeded.

8 Wake Up Level

Level is a percentage of the set reference range. This parameter determines the level of the actual value at which the SAMI GS will restart. If the reference value is set below the

set wake-up level while the sleep function is active, the SAMI GS will restart when the actual value goes below the new set reference value as shown in Figure 9-18 below.

Note! Wake-up level is calculated from the scaled actual value. For example, with 4 to 5 bar scaled actual value range a 10 % wake-up level corresponds to 4.1 bar.

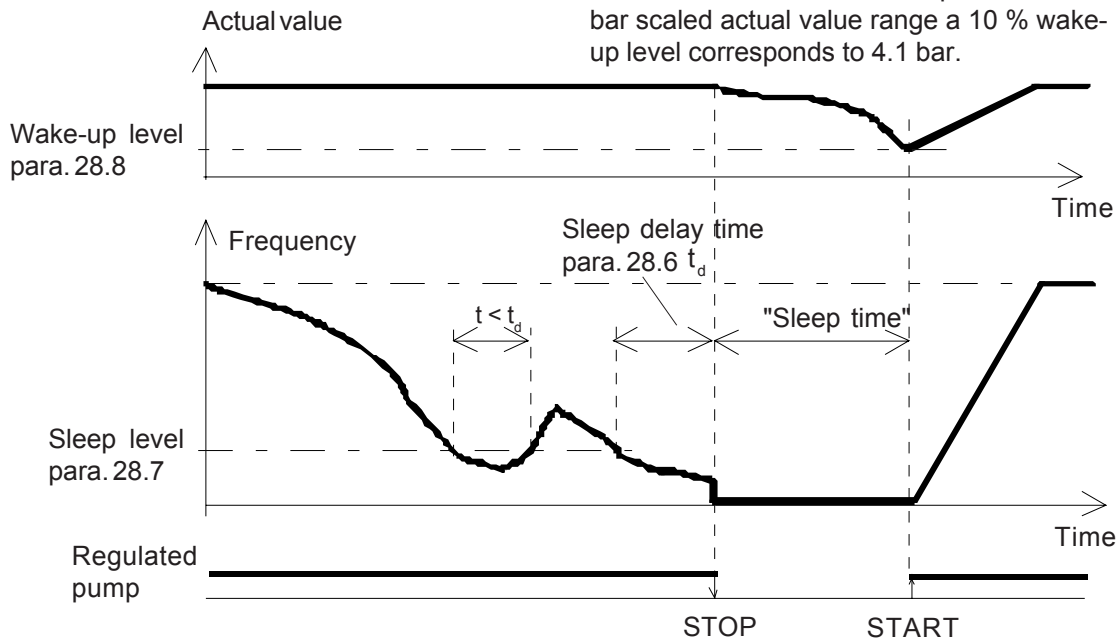

Figure 9-18. Example of the sleep function.

9 Start Freq 1

10 Start Freq 2

11 Start Freq 3

Output frequency at which the first (second, third) auxiliary motor will start. The start frequency has a fixed 1 Hz hysteresis.

12 Low Freq 1

13 Low Freq 2

14 Low Freq 3

Minimum frequency to the regulated motor after start of the first (second, third) auxiliary motor. If the output frequency goes below this limit by 1 Hz, the auxiliary motor will stop.

15 Aux Mot Start DLY

Start delay of auxiliary motors to prevent starting at a momentary crossing of the start limit, e.g. due to pressure impacts in water supply systems.

16 Aux Mot Stop DLY

Stop delay of the aux. motors to prevent stopping at a momentary crossing of the stop limit, e.g. due to pressure impacts in water supply systems.

17 NBR of Aux Motors

Number of auxiliary motors.

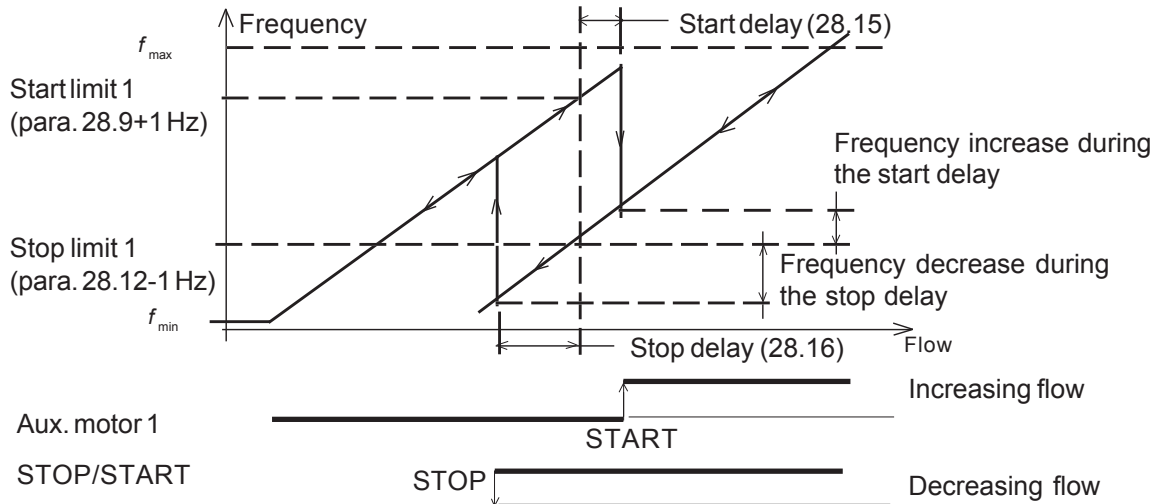

Figure 9-19. Example of pump control.

18 Autochange Interv.

Elapsed time for automatic exchange of the connected motors. The Parameter determines the time after which the starting order of the connected motors will be automatically altered. Alternation is possible only when the actual signal goes below the limit set with parameter 28.19. In basic order, relay output RO1 controls the regulated motor and relays RO2 to RO4 *) control the constant speed motors.

Setting the value 00 h 00 min disables the automatic exchange function and basic order will be used. The interval time counter is only active when the SAMI GS is running.

19 Autochange Level

Actual value below which automatic exchange of the connected auxiliary motors will occur after the time set with parameter 28.18 has elapsed.

Setting the value 0 % ensures automatic exchange takes place when the SAMI GS is stopped (normal or "sleep"). After this, start takes place only when giving a new start command. The autochange level is related to the set max. frequency and to the capacity of the system. If the value of the parameter is set to 45 % and the system has only two mo-

tors, the automatic exchange takes place at the frequency of $(45/50) * f_{max}$. If auxiliary motors are connected, the percentage value corresponding to the set max. frequency is:

1+1	motors	50.0 %
1+2	-"	33.3 %
1+3	-"	25.0 %

The exchange takes place if the following conditions are valid:

- autochange interval time has elapsed
- actual value is below the set autochange level
- minimum one auxiliary motor is not running
- SAMI GS does not run at a constant frequency (see parameter 11.7).

When all the conditions are valid PFC stops all motors, changes the order of the motors and restarts motors using the new start order. The start order cannot be changed externally. The start order and the elapsed run time remain in the memory during a mains interruption.

Note! If only the regulated pump is used, cancel the autochange operation, para. 28.18 = 00 h 00 min. This releases relay outputs RO2 to RO4 *) for other use.

*) RO4 only available with I/O Extension card

SNAT 7520 IOE

20 Interlocks

If this parameter is set to ON and one of the interlocking signals disappears while in run status, the SAMI GS stops and all output relays (RO1 to RO4*) are released.

If other motors are available, the PFC connects one of those instead and starts the SAMI GS again. If this parameter is set to OFF, the interlocking function is disabled and DI2, DI3 and DI4 (DI7*) can be programmed for other purposes.

*) available only with I/O Extension card SNAT 7520 IOE

21 Error Value Inv

The parameter determines whether or not the PI-Controller error signal is inverted.

22 Actual 1 Input

The parameter determines which of the analogue inputs is actual value 1 (ACT1). AI3 and AI4 can be set if the I/O extension card is in use. STD COMMU = control via RS 485 serial link. The Parameter value can be changed only in stop status.

23 Actual 2 Input

The parameter determines which of the analogue inputs is actual value 2 (ACT2). AI3 and AI4 can be set if the I/O extension card is in use. The parameter value can be changed only SAMI GS is stopped.

24 Actual Value Sel

The following mathematical operations can be performed with the actual signals:

- ACT1 ACT1 without any operations
- ACT1-ACT2 Difference of ACT1 and ACT2
- ACT1+ACT2 Sum of ACT1 and ACT2
- ACT1 * ACT2 Product of ACT1 and ACT2
- MIN(A1,A2) Min. value of ACT 1 and ACT2

- MAX(A1,A2) Max. value of ACT1 and ACT2
- sqrt(ACT1) Square root of ACT1
- sqA1+sqA2 Sum of sq. roots of ACT1 and ACT2

All operations are performed to the scaled values. Square root signals can be used for example for flow control where the measured actual value is pressure.

25 ACT1 Min Scale,

27 ACT2 Min Scale

Scaling factor to match ACT1 (ACT2) to a minimum value of the reference signal.

26 ACT1 Max Scale

28 ACT2 Max Scale

Scaling factor to match ACT1 (ACT2) to a maximum value of the reference signal.

29 Regul Bypass Ctrl

Bypass selection of the PI-Controller. If bypassed, the actual value acts as a direct speed reference for the regulated motor. Automatic start and stop of constant speed motors also refers to the actual value signal instead of the output of the PI-Controller. See

Frequency = $f(\text{ACT } 1)$

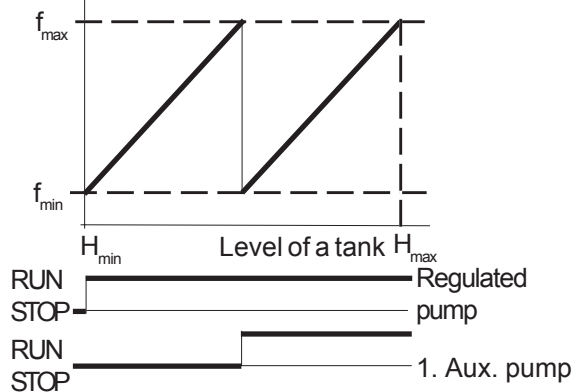

Figure: 9-20. Example of flow control of precipitation tanks using PI-Controller by-pass function.

Figure below.

30 Display Unit

Unit of ACT 1 and ACT 2 shown on the display. Units: bar, %, m/s, C (= °C), kPa,

l/min, m3/min.

31 Displ Unit Scale

Scaling factor for display unit.

32 NBR of Decimals

Number of decimal digits of the displayed actual values.

9.3 Main 30 - Protection

9.3.1 Group 31 - Supervision

These values can be altered with the SAMI GS running.

Parameter	Range/Unit	Description
1 Output Freq1 Func	No/Lowlimit/Highlimit	Output Frequency 1 supervision
2 Output Freq1 Lim	0...120/150 Hz*)	Output Frequency 1 supervision limit
3 Output Freq2 Func	No/Lowlimit/Highlimit	Output Frequency 2 supervision
4 Output Freq2 Lim	0...120/150 Hz*)	Output Frequency 2 supervision limit
5 Current Func	No/Lowlimit/Highlimit	Motor Current supervision
6 Current Lim	0...2 * I _N [A]	Motor Current supervision limit
7 Ref1 Func	No/Lowlimit/Highlimit	Reference 1 supervision
8 Ref1 Lim	0...120/150 Hz*)	Reference 1 supervision limit
9 Ref2 Func	No/Lowlimit/Highlimit	Reference 2 supervision
10 Ref2 Lim	0...100%	Reference 2 supervision limit
11 Supervis Messages	On/Off	Supervision messages on the display

*) Max. value is set automatically according to the setting of parameter 22.4.

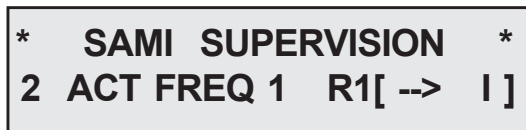

Figure 9-21. Example of supervision display.

1 Output Freq1 Func

3 Output Freq2 Func

These parameters allow you to activate an Output Frequency supervision function. A Relay Output (para. 14.3 - 14.5) and the display are used to indicate that the Output Frequency has dropped below (LOWLIMIT) or exceeded (HIGHLIMIT) the supervision limit.

5 Current Func

Motor Current supervision. Operation as in parameter 1 OUTPUT FREQ1 FUNC.

7 Ref1 Func, 9 Ref2 Func

Reference supervision. Operation as parameter 1 OUTPUT FREQ1 FUNC.

11 Supervis Messages

ON = Supervision messages will be shown on the display.

OFF = Supervision messages will not be shown on the display. Relays operate if programmed for supervision signals.

9.3.2 Group 32 - Fault Function

These values can be altered with the SAMI running.

Parameter	Range/Unit	Description
1 Serial Fault Func	Stop/Const Freq	Operation following Serial Comm. fault
2 AI < 2 V/4 mA Func	No/Warning/Fault/ Const Freq	Operation following AI<2 V/4 mA fault
3 Mot Temp Flt Func	No/Warning/Fault	Operation in case of motor overtemp.
4 Motor Therm Time	300...10000s	Time for 63% motor temperature rise
5 Motor Load Curve	50...150%	Motor current maximum limit
6 External Fan	No/Yes	Motor equipped with external cooling fan
7 Stall Func	No/Warning/Fault	Operation following motor stall
8 Stall Current	0...1.5 * I _N [A]	Current limit for Stall Protection logic
9 Stall Time/Freq	10s/15Hz or 20s/25Hz or 30 s/35 Hz	Time/Freq. limit for Stall Protection logic
10 Underload Func	No/Warning/Fault	Operation following Underload fault
11 Underload Time	0...600s	Time limit for Underload logic
12 Underload Curve	1...5	Torque limit for Underload logic

1 Serial Fault Func

This parameter allows you to select the preferred operation following a malfunction in the serial communication between the Control Interface and Motor Control Card.

STOP

The SAMI GS stops according to the setting of parameter 26.3, STOP FUNCTION.

CONST FREQ

The SAMI drives the motor at the constant frequency selected by parameter 24.7.

Note! If the selected control place is KEYPAD, the SAMI GS stops when a serial communication fault occurs.

2 AI < 2V/4mA Func

This parameter allows you to select the preferred operation when the Analogue Input (1 or 2) signal drops below 2V/4mA and the minimum is set to 2V/4mA ("living zero").

NO

No activity required.

WARNING

Warning indication on display.

FAULT

Fault indication on display and the drive has stopped according to the setting of parameter 26.3 STOP FUNCTION.

CONST FREQ

The SAMI GS drives the motor with the constant frequency selected by parameter 24.7.

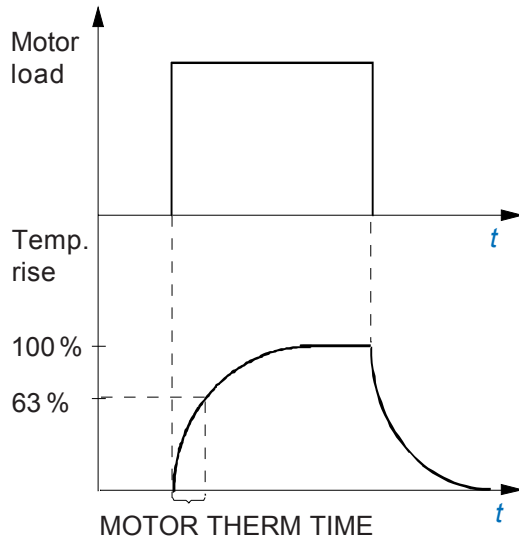

Figure 9-22. Motor thermal time.

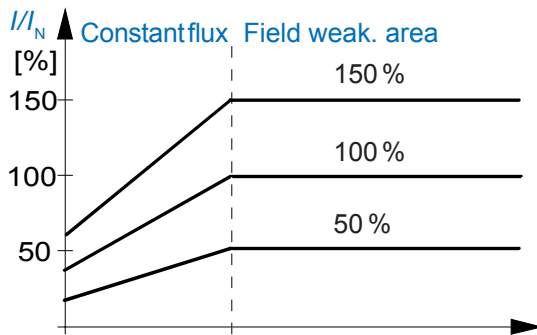

Figure 9-23. Motor load curve (EXTERNAL FAN = NO).

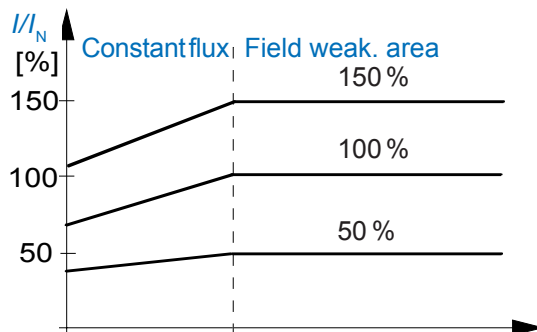

Figure 9-24. Motor load curve (EXTERNAL FAN = YES).

3 Mot Temp Flt Func

This parameter defines the operation of the motor thermal protection function.

No activity required.

Warning indication is displayed when the motor temperature reaches the warning level (95 % of the nominal value).

Warning indication at warning level and fault indication + stop when the motor temperature reaches 100 % level.

4 Motor Therm Time

MOTOR THERM TIME is the time period within which the motor temperature reaches 63 percent of the final temperature rise. As a rule of thumb, MOTOR THERMAL TIME = $120 * t_6$ (t_6 in seconds is given by the motor manufacturer). The SAMI GS automatically selects a typical motor thermal time as a default value according to the selected motor power and pole number. Table 9-1, page 70.

5 Motor Load Curve

6 External Fan

The motor connected to the SAMI GS can be protected from overheating by the motor thermal protection. The SAMI GS will calculate the temperature rise of the motor using the following assumptions:

- the ambient temperature is 40 °C
- the motor is at ambient when power is applied to the SAMI GS
- when stopped, the motor cooling time is 4 times the cooling time when running

Motor heating is calculated assuming a load curve. The load curve is defined by the MOTOR LOAD CURVE and EXTERNAL FAN parameters.

Table 9-1. Default values of motor thermal times when motor power and pole number are selected from START-UP Data group. These values are typical for each motor size. Default value of pole number is 4.

P_N [kW]	Number of poles		
	2 t [s]	4 t [s]	6 t [s]
37	1860	2460	3180
45	2040	2640	3420
55	2220	2820	3660
75	2400	3120	3960
90	2640	3300	4320
110	2820	3600	4680
132	3120	3960	5100
160	3420	4320	5700
200	3780	4740	6420
250	3780	4740	6420
315	3780	4740	6420

If MOTOR LOAD CURVE is set to 100 %, the Motor Thermal Protection allows the motor to be loaded with nominal current. The load curve level should be adjusted if, for example, the ambient temperature differs from the nominal value.

The motor temperature will rise above nominal when the motor operates in the region above the curve, and will fall when operated below the curve. The rate of heating and cooling is set by MOTOR THERM TIME.

Because of the simple thermal model used for calculating temperature rise, this technique of thermal protection may cause undesirable trips when the motor is run continuously at low frequencies. If your application requires continuous running at frequencies lower than 25 Hz, you may need to provide external cooling.

When using external cooling, set EXTERNAL FAN to YES. The load curve will be fixed to 70 % current at 0 Hz.



Note! Motor thermal protection will not protect the motor if the cooling efficiency of the motor is reduced due to dust and dirt.

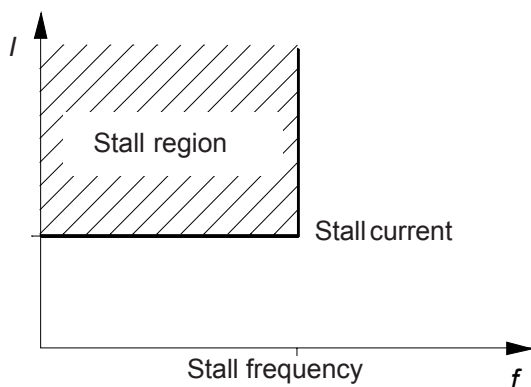

Figure 9-25. Stall Protection.

7 Stall Func

This parameter defines the operation (NO/WARNING/FAULT) of the Stall Protection.

The protection is activated if

- 1) the motor current exceeds the limit set in parameter 32.8, STALL CURRENT,
- 2) the output frequency is below the level set in parameter 32.9, STALL TIME/FREQ and
- 3) the motor current remains above and the output frequency below the set limit longer than the period set in parameter 32.9.

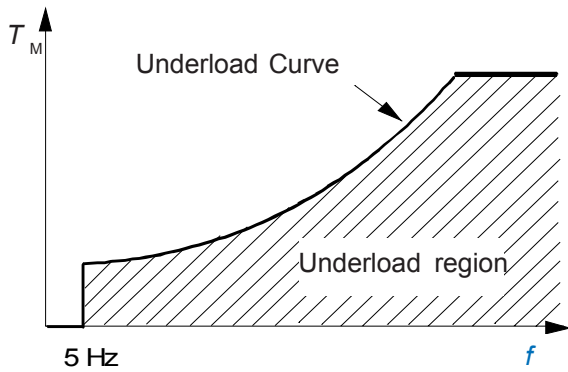

Figure 9-26. Underload Protection.

10 Underload Func

A process malfunction can sometimes appear as a removal of motor load, which is detected by underload protection. The protection is activated if

- 1) the motor torque drops below the load curve selected in parameter 32.12, UNDERLOAD CURVE,
- 2) the motor torque remains below the load curve longer than the period set in parameter 32.11, UNDERLOAD TIME and
- 3) the output frequency is more than 5 Hz.

The protection function assumes that the drive is equipped with a nominal size motor.

Select NO/WARNING/FAULT as desired.

Refer to Figure 9-27 for UNDERLOAD CURVE selection.

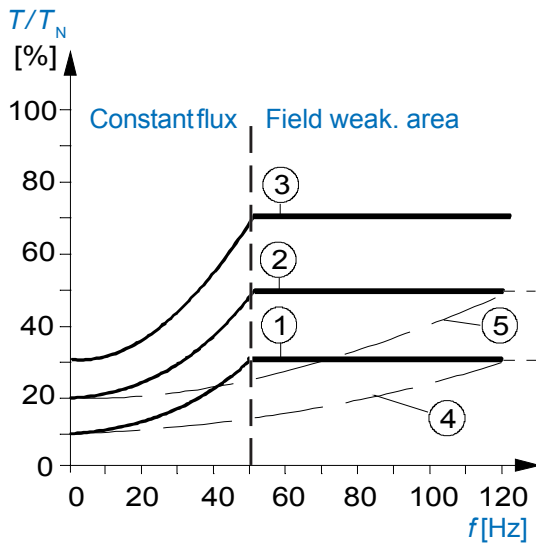

Figure 9-27. The five available curve types in parameter 32.12 UNDERLOAD CURVE.

9.3.3 Group 33 - Automatic Reset

These values can be altered with the SAMI GS running.

Parameter	Range/Unit	Description
1 Number of Trials	0...5	Max. number of trials for Autoreset logic
2 Trial Time	1...180s	Time limit for Autoreset logic
3 Overvoltage	No/Yes	Enable automatic fault reset
4 Undervoltage 1	No/Yes	Enable automatic fault reset
5 Overcurrent	No/Yes	Enable automatic fault reset
6 AI signal <2 V/4 mA	No/Yes	Enable automatic fault reset

1 Number of Trials

2 Trial Time

The maximum number of faults per time period to keep the Automatic Fault Reset System active is given by parameters 33.1 and 33.2.

If more faults occur within TRIAL TIME, the drive stops.

The automatic fault reset system will reset the faults selected with parameters 33.3 - 33.6.

3 Overvoltage

4 Undervoltage

If you select YES, the SAMI GS will resume

operation when the DC bus voltage returns to normal level. If para. 33.1, NUMBER OF TRIALS is set to 0 (and this parameter is set to YES) the undervoltage fault will be continuously reset, and the fault will not be updated in the Fault History. In this case, the fault is virtually undetectable.

5 Overcurrent

If you select YES, the fault is resetted automatically and the SAMI GS resumes normal operation.

6 AI Signal < 2V/4mA

If you select YES, the SAMI GS resumes normal operation when the Analogue Input signal recovers the normal level ($\geq 2V/4mA$).

9.3.4 Group 34 - Information

The parameter values can not be altered by the user.

Parameter	Range/Unit	Description
1 Cri Prog Version	CRlxy	Control Interface Card program version
2 MC Prog Version	CNTxy	Motor Control Card program version
3 Test Date	DD.MM.YY	Test date (day.month.year)

1 Cri Prog Version, 2 MC Prog Version

xx are running integers, which correspond to the version. y is a letter corresponding to the revision.

3 Test Date

Replacing the Control Interface Card will result in a new date. To be sure of the date of manufacture, check the name plates on the units or cards.

10 Fault Tracing & Service

10.1 Fault Indications

The SAMI GS continuously monitors itself during operation. If a fault condition should arise, the SAMI GS will display a description of the fault trip and wait for the operator to acknowledge the fault before resuming operation.

The SAMI GS will also display warnings, which indicate abnormal operation, but do not cause the drive to stop. If a fault occurs when a warning display is on, the warning will be erased and the fault indication displayed. Refer to the table on page 75 for warning and fault indications.

10.2 Fault Resetting

A fault can be reset either by pressing the Keypad Start/Stop button, activating the selected Digital Input (parameter 11.9), via serial communication (RS 485) or if necessary, switching the mains voltage off for a while. If the fault has been removed, the SAMI GS will resume normal operation. If the fault has not been removed, the SAMI GS will trip again. For automatic fault reset, refer to Group 33 on page 72.

Note! Fault resetting starts the drive, if Start command is active.

If the fault persists, it will trip the drive again, resulting in a new fault indication. However, to allow parameters to be checked or altered after resetting a fault, there is a 1 minute delay, during which no new faults are displayed, unless Start command becomes active. During this delay, the state of the fault relay output will follow the actual fault situation, as will the fault registering into the Fault History. If the autoreset function is selected, these faults will also be reset.



Some faults require the user to switch the power off and on before the fault can be cleared. Proper fault reset action is given in the fault message Table on pages 75 - 79.

10.3 Fault History

When a fault is detected, it is stored so that it can be reviewed at a later date. The last three faults and warnings are stored in Operating Data parameters, 20 LAST-RECD FAULT, 21 SECOND-RECD FAULT, 22 FIRST-RECD FAULT).

The faults can be checked for trends that may be useful in preventing future faults. For example, if the last 2 out of 3 faults were overvoltage trips, the deceleration time should be increased.

Scrolling through the Fault History parameters does not erase the Fault History. The oldest reset fault indication/warning is automatically erased when a new fault/warning occurs.

To erase the Fault History, each Fault History parameter must be set to zero. Select parameter 20, LAST RECD FAULT and change to Setting mode. Press  or  until the parameter value changes to zero. Return to Display mode by pressing . Repeat the same steps with parameters 21 and 22.

Note! Erasure of the Fault History is prevented, if the fault persists after it has been reset (during the one minute delay described in Section 10.2).

Note! Whenever an Application Macro is selected (Start-up Data para. B APPLICATION), the Fault History will also be reset.

SAMI GS

```
* *   SAMI WARNING   * *  
7 A I < 2V/4mA  R1[ --> I ]
```

```
* * *   SAMI FAULT   * *  
*  
8 OVER CURR1 R1[ --> I ]
```

Figure 10-1. Examples of warning and fault displays.

Note! Undervoltage faults are stored in the Fault History only when Automatic Reset is off. Supervision limit indications are not stored in the Fault History but remain on display until reset by pressing I/O or by external fault reset. The source of external fault reset can be selected by parameter 11.9.

Note! Factory testing for the SAMI GS includes tripping function. However, the Fault History is always erased before shipment, which means that any faults within the history have occurred after shipment.

10.4 Fault Tracing with a Fault Display

The Table below shows the displayed fault text, the probable reason for the fault and advice on correcting the fault. The proper fault reset action is indicated below the fault message:





 = Reset with one signal,   = Switch off input power.

If after following the advice given the fault persists, contact the nearest SAMI service representative.





In most cases the process disturbances are not related to a hardware failure in the SAMI GS, but are caused by unexpected environmental or load conditions.

The principle of all fault tracing is to identify and isolate the cause and then remove it.





If the fault is caused by hardware failure within the SAMI GS, the fault tracing procedure should allow quick on site repair.

Warning message	Possible reason	Remedy
1  SAMI temp	SAMI GS heatsink temperature > 75 °C. Restricted air flow caused by dust or improper installation; overloading or a component failure (fan, fuse, power semiconductors). If this warning arises on switch-on, it is possible that terminal X307 on the Main Circuit Interface Card is loose.	<ul style="list-style-type: none"> - Check ambient temp. (< 40 °C) - Check installation (air flow). - Check heatsink fins, remove any dust or dirt. - Check for component failures - Check terminal X307. - Check fuses on SNAT 790x INP - Check that T61 primary and secondary connections are OK. - Check that the SAMI was not overloaded for a long period. - If the fault persists, contact SAMI service representative.
2  Mot stall	Parameter 32.7, STALL FUNC is set to WARNING.	- Refer to fault 3, Mot stall.
3  Mot temp	Parameter 32.3, MOT TEMP FLT FUNC is set to WARNING.	- Refer to fault 4, Mot temp.
6  Under Id	Parameter 32.10, UNDERLOAD FUNC is set to WARNING.	- Refer to fault 7, Under Id.
	Parameter 32.2, AI < 2V/4mA FUNC is set to WARNING.	- Refer to fault 11, AI < 2V/4mA.







SAMI GS

7 AI <2V/4mA Warning message	Possible reason	Remedy
8  EEPROM wr	Parameter storage to EEPROM has failed.	<ul style="list-style-type: none"> - Check DC-link voltage. - If voltage is OK, try to store again. - If warning occurs again, try to restore factory settings. - If the warning persists, contact the nearest SAMI service representative.
10  Op card 1	Speed Control Macro selected but no Pulse Tachometer Card connected.	<ul style="list-style-type: none"> - Check that the card is present. - Check the connections.
Fault message	Possible reason	Remedy
1  Start/Stop	The start/stop reference from the Control Interface Card is different from the start/stop-state of the Motor Control Card.	<ul style="list-style-type: none"> - Check the connection between Control Interface and Motor Control Cards. - If the fault persists, contact the nearest SAMI service representative.
2  SAMI temp	The SAMI GS heatsink temperature > 85°C or less than -10°C. Restricted air flow caused by dust or improper installation; overloading or a component failure (fan, fuse, power semiconductors). If the display shows -18°C temperature when the ambient (and heatsink) obviously is warmer, the thermostat S1 has opened (due to Rectifier bridge overtemperature). If this fault appears at start, it is possible that terminal X307 on the Main Circuit Interface Card is loose.	<ul style="list-style-type: none"> - Check ambient temperature (<40°C). - Check heatsink fins, remove any dust or dirt. - Check that the SAMI was not overloaded for a long period. - Check the fan and air flow. - Check terminal X307. - Check the fuses on SNAT 790x INP. - If the temperature display was negative, also check line fuses. - Check that T61 primary and secondary connections are OK. - If the fault persists, contact SAMI service representative.
	The SAMI GS has determined that the motor is operating in the stall region. Refer to STALL TIME/FREQ parameter. The motor is not turning because of increased load torque. Motor may be too small for the application.	<ul style="list-style-type: none"> - Remove mechanical problem causing increased load torque. - If the motor shaft is rotating and the motor is not overheating, increase stall limit parameters. - Check dimensioning, use larger SAMI GS and motor if necessary.







SAMI GS

Fault message	Possible reason	Remedy
3 Mot stall 4 Mot temp 	<p>The SAMI GS has determined that there is a high probability that the motor is overheated. Because the temperature rise is calculated from the motor current and not measured directly, the motor may still be within temperature specification.</p>	<ul style="list-style-type: none"> - Check the motor temperature. If it is within temperature specification, increase MOTOR LOAD CURVE and/or MOTOR THERM TIME and restart. - If the motor temperature is above rated temperature, improve motor cooling or resize the motor.
7 Under Id 	<p>The motor load has dropped below the supervision limit set by parameters 32.11 and 32.12.</p>	<ul style="list-style-type: none"> - Remove mechanical problem causing underload. - Check motor load cycle and increase UNDERLOAD TIME or change UNDERLOAD CURVE.
8 Overcurr1 	<p>The output current instantaneous value has exceeded 375 % I_N. This can be caused by short circuit in the motor, motor cable or in the SAMI GS. Too short an acceleration time may also cause an overcurrent trip. Also sudden shocks in the load torque may be the cause of this trip. If the field weakening point is set too low or if there is too much IR-compensation, an overcurrent trip may follow. An oversized motor may also be the cause.</p>	<ul style="list-style-type: none"> - Check the load torque conditions and acceleration time. - Make sure that there is no short circuit or earth fault in the motor circuit. - See that there are no other loads than the motor (especially capacitors) connected to the SAMI output.
9 Overvolt 	<p>DC-bus voltage has exceeded 130 % nominal voltage (nom. Volt. = $1.35 * U_{1max} \cdot U_{1max} = 415/500/600$ V). Most common cause for this is overvoltage (static or transient) in the mains supply. Overvoltage can result also, when the motor runs as a generator in drives where the load inertia is extremely high and the deceleration time is set low.</p>	<ul style="list-style-type: none"> - Check the mains supply for static or transient overvoltages. (e.g. are there generating loads or large power factor correction capacitors upstream?) - Use longer deceleration time or - Use coasting stop function if it is compatible with the application. - If short decel. time is needed use Dynamic Braking Device.

SAMI GS

Fault message	Possible reason	Remedy
10  Underv1	DC-bus voltage has gone below 65% of U_N (Start-Up Data para. D). Most common reason for low voltage trip is failure in the mains supply, loss of phase or "brown out" condition.	<ul style="list-style-type: none"> - Check mains fuses and supply. - If mains supply is adequate, an internal failure has occurred. Contact the nearest SAMI GS service representative.
11  AI < 2V/4mA	Analogue input less than 2V/4 mA and minimum has been set to 2 V/ 4 mA.	<ul style="list-style-type: none"> - Input reference has failed or control wire is broken. Check the reference circuit.
14  Op Card 1	The frequency converter software does not receive the optional board SNAT 7610 BAC identification code (card not connected or failed). The drive stops according to the setting of parameter 26.3 STOP FUNCTION.	<ul style="list-style-type: none"> - SPEED CONTROL application macro can not be used without optional board SNAT 7610 BAC. Select any other macro. If SNAT 7610 BAC is used see its Operation Guide.
16   Pow Rang	Power range programming does not match after replacing the Control Interface or Main Circuit Interface Card.	<ul style="list-style-type: none"> - Check the Matching Card (on top of Main Circuit Interface Card). - Check that the Start-up Data is given accordingly for the new Control Interface Card. - Remove power, wait one minute, then restore power. If the fault persists, contact the nearest SAMI service representative.
17  RS 485	No serial communication on RS 485 at connector X51. EMC disturbances on serial link.	<ul style="list-style-type: none"> - If no serial communication ought to be present, set para. 17.4 to "NO". - Check connectors, bit rate. - Check parameter 17.3 - Remove reasons for disturbances.
19  In comms	Failure in serial communication within the Control Interface and/or Motor Control Cards.	<ul style="list-style-type: none"> - Check the cabling between Control Interface and Motor Control Cards. - If the fault persists, contact the nearest SAMI service representative.

SAMI GS

Fault message	Possible reason	Remedy
20  Con intX 	This fault is related to components on the Control Interface Card.	<ul style="list-style-type: none"> - Remove power, wait one minute, then restore power. If the problem persists, call the nearest SAMI GS service representative. Record the specific fault code, you may be asked for it.
21  Mot contX 	This fault is related to components in the Motor Control Card or in the Converter Module. The X in the fault message conveys the following: 1=U2 phase current measurement problem 2=V2 phase current measurement problem 3=DC-voltage measurement problem 4=serial communication problem 5=power supply problem on SNAT 7780 6=too high ripple content in DC-voltage, caused possibly by a mains fuse failure or phase loss/unbalance.	<ul style="list-style-type: none"> - Check for the fault indicated by the code number. - Make sure the load is not vibrating. - If the fault persists, check the Input Protection Card and/or Rectifier modules. - For faults 1...5, remove power, wait one minute, then restore power. If the problem persists, contact nearest SAMI service representative. Record the specific fault code, you may be asked for it.
22  Par rest	Parameter restoring error. Parameter checksum does not match.	<ul style="list-style-type: none"> - Reset fault display (the display is reset allowing parameters to be scrolled, but the fault is not reset). - Check all parameter settings or reset the factory settings. - Remove power, wait 1 minute, then restore power to check that the fault has disappeared.
23  Underv2	DC-bus voltage does not rise over 80 % of its nominal value ($1.35 * U_N$) within 5 sec. of connecting the mains. In RUN status DC-bus voltage remains below 82.5 % for more than 3 min.	<ul style="list-style-type: none"> - Check mains supply. - If mains supply is adequate an internal failure has occurred. Contact nearest SAMI service representative.

**SAMI
GS**

Fault message	Possible reason	Remedy
24  Earth fl	Earth leakage current at start is more than 5 % of the nominal current I_N .	<ul style="list-style-type: none">- Disconnect the mains, wait 5 minutes and ensure by measurement that the DC-voltage is zero. Disconnect the motor cables and check the motor circuit isolations. If no earth fault or short-circuit between phases exists, contact nearest SAMI service representative.

10.5 Other Fault Situations

There may be some other fault situations that need to be corrected, where no help can be obtained from the display.

One of these is the case when nothing seems to happen when power is applied to the SAMI GS. Refer to the Flowchart 10-1 for that case.

If parameter 27.11 O/U VOLT CONTROL is set to YES, the internal logic of SAMI GS prevents starting the drive if the dc-link voltage is over 117 % of its nominal value as derived from the Start-up Data parameter D SUPPLY VOLTAGE (U_N) (the limit for preventing is $1.17 * 1.35 * \text{SUPPLY VOLTAGE}$). If in doubt, check these parameters and dc-link voltage.

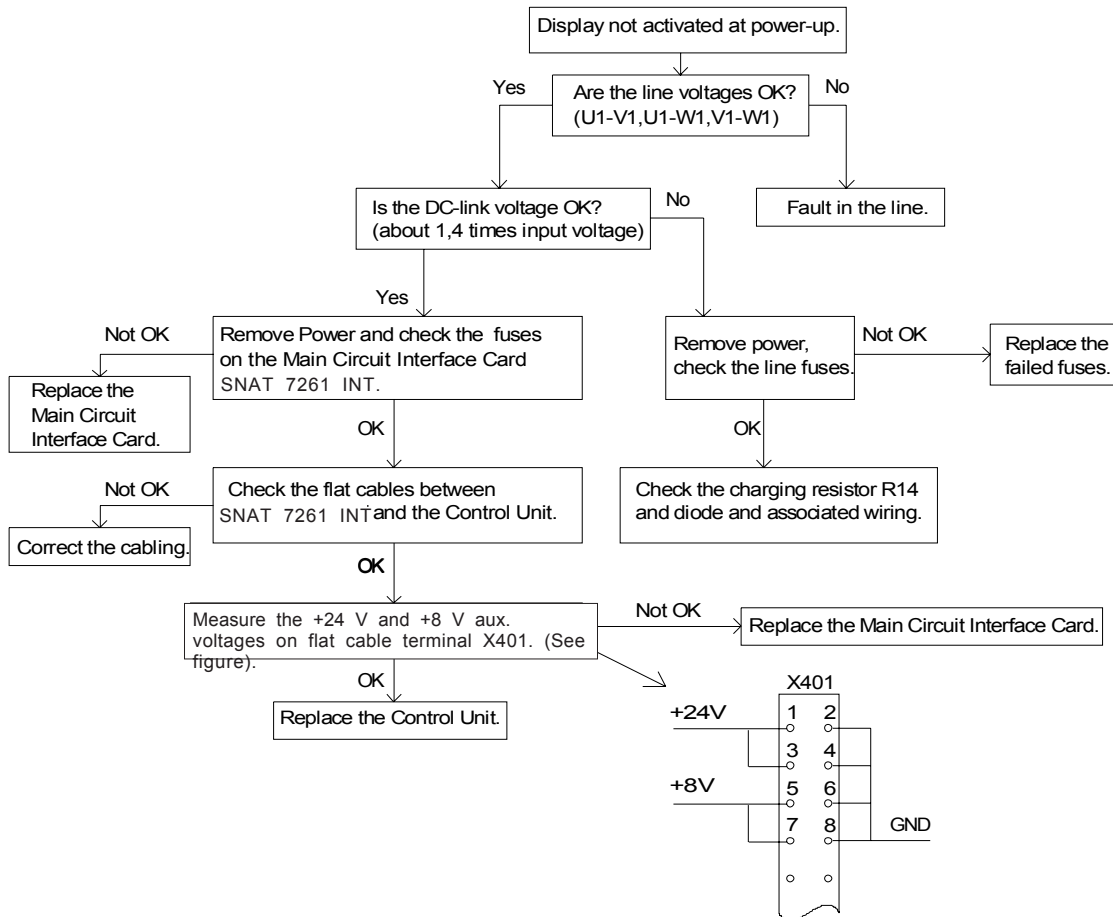

Flowchart 10-1. Flow of actions if the display is not activated when power is applied.

10.5.1 LED Indications on the Main Circuit Interface Card

If you remove the front cover of the Converter Module, you will see the Main Circuit Interface Card. There is a 7-segment LED digit on the bottom part of that card. In normal operation +15 V and +24 V (Gate driver) LEDs are illuminated. See Figure 10-2.

If segment +24 V or +15 V is dark, the corresponding internal auxiliary voltage has

dropped too low. This fault is not indicated on the display and can thus not be reset (fault in the Main Circuit Interface Card). The green LED (Power) on upper part of the card is illuminated when the power supply is operating normally. If you disconnect the mains, the red LED (Discharge) above the green one will turn on for a while, as the DC-bus is being discharged.

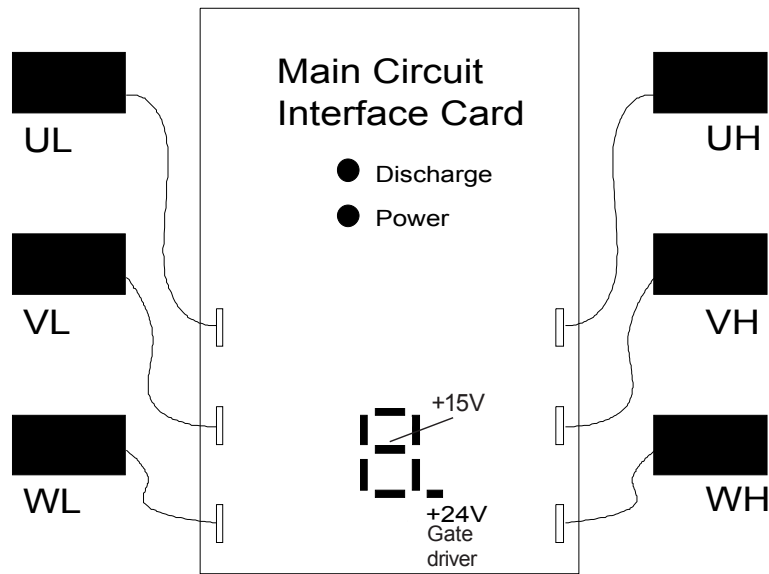

Figure 10-2. LEDs on the Main Circuit Interface Card and relative position of the Inverter transistors. L stands for lower arm, H for upper arm of the inverter phase.

10.6 Service

Key to the serial numbers on the SAMI GS

There are name plates on various parts of the SAMI GS. In addition to the type and code of the part or unit in question, these plates have the serial number printed on them. When servicing a unit, it may be needed to decode the information given by the name plates.

Serial number of the SAMI (or Converter Module or Control Unit)

Example: SER NO: 2110003

2 1992
11 week 11
0003 third unit tested on that week

Serial number of Control Interface Card

Example: NO: 7600ABC2110093

7600 SNAT 7600
A component/schematic revision
B printed circuit card revision
C software revision
2 1992
11 week 11
0093 93rd SNAT 7600 tested on that week

Name plates of other cards

Example: TYPE: SNAT 7261 ABC SER NO: 2110006

SNAT 7261 SNAT 7261 INT
A part list revision
B printed circuit card revision
C schematic revision
2 1992
11 week 11
0006 6th SNAT 7261 INT tested on that week

10.7 Spare Parts

Control Interface Card

<i>Card</i>	<i>Order code</i>
SNAT 7600/7640 CRI	61027319

Optional Control Cards

Optional Control Cards are to be ordered separately.

SNAT 752x IOE	61044396
SNAT 7670 EFS	61033637
SNAT 7610 BAC	58420069
SNAT 7690 RS232/20mA	61042105

The order codes for the other spare parts are listed in the following tables. There is a table for the braking choppers, line fuses, options and a table for Converter Modules. **Note!** Together with the spare, you will also receive documentation and accessories for correct assembly. Some spares come as a kit.

The numbers on the row following the order code indicate the number of built-in components (kits) for each SAMI GS type. The SAMI GS type is indicated in the first row of the tables.

Optional & Input devices (380V and 500V units)

Order code	Item	ACS 50X-051- 3	ACS 50X-061- 3	ACS 50X-071- 3	ACS 50X-100- 3	ACS 50X-120- 3	ACS 50X-140- 3	ACS 50X-170- 3	ACS 50X-210- 3	ACS 50X-260- 3	ACS 50X-061- 5	ACS 50X-071- 5	ACS 50X-100- 5	ACS 50X-120- 5	ACS 50X-140- 5	ACS 50X-170- 5	ACS 50X-210- 5
58424595	Braking chopper (compl. kit) A9	1	1				1	1									
58424609	Braking chopper (compl. kit) A9		1					1									
58424617	Braking chopper (compl. kit) A9			1	1	1	1	1	1	1	1						
58424625	Braking chopper (compl. kit) A9						1										1
58423980	Line Fuses F1.1-F1.3 (3 pcs kit)	1					1										
58423998	Line Fuses F1.1-F1.3 (3 pcs kit)		1	1				1	1								
58424005	Line Fuses F1.1-F1.3 (3 pcs kit)			1	1				1	1							
58424013	Line Fuses F1.1-F1.3 (3 pcs kit)				1					1							
58424021	Line Fuses F1.1-F1.3 (3 pcs kit)					1	1				1	1					
58424030	Line Fuses F1.1-F1.3 (3 pcs kit)						1										1
10004993	Fuses F2.1, F2.2 (2 pieces kit)	1	1	1	1			1	1	1	1						
09844791	Fuses F2.1, F2.2 (2 pieces kit)				1	1	1	1	1		1	1	1	1	1	1	1
58424633	IP 54 Cabinet Fan Y1	1	1	1	1	1		1	1	1	1						
58424641	IP 54 Cabinet Fan Y1					1	1							1	1		

If a fuse fails after several years of duty without a definite reason (overload, fault), it is recommended to replace all the fuses.

**SAMI
GS**

Components in Converter Modules (380 V and 500 V units)

Order code	Item	ACS 50X-051-3	ACS 50X-061-3	ACS 50X-071-3	ACS 50X-100-3	ACS 50X-120-3	ACS 50X-140-3	ACS 50X-170-3	ACS 50X-210-3	ACS 50X-260-3	ACS 50X-661-5	ACS 50X-071-5	ACS 50X-100-5	ACS 50X-120-5	ACS 50X-140-5				
58424048	Fan fuses (2 in a kit) A8:F1, F2	1	1	1	1	1	1	1	1	1	1								
58424064	Main Circuit Int. Card SNAT7261	1	1	1	1	1	1	1	1	1	1								
5842xxxx	Matching Card SNAT xyzv (one per unit)	4366	4374	4382	4391	4404	4412	4421	4439	4447	4455	4463	4471	4480	4498	4501	4510	4528	4536
58424081	Input Protection Card SNAT 7901*)	1	1	1	1	1	1	1	1	1									
58424099	Input Protection Card SNAT 7902	1	1	1	1	1	1	1	1	1	1	1	1	1	1	1	1	1	1
61027319	Cont. Interf. Card SNAT 7600/7640	1	1	1	1	1	1	1	1	1	1	1	1	1	1	1	1	1	1
61027289	Motor Control Card SNAT 7780	1	1	1	1	1	1	1	1	1	1	1	1	1	1	1	1	1	1
58424102	Current transducer (1 piece) U21..	2	2	2	2	2					2	2	2	2	2				
58424111	Current transducer (1 piece) U21..						2	2							2	2			
58424129	Current transducer (1 piece) U21..								2	2							2	2	
58424137	Converter Module fan(s) Y61 (Y62)	1	2	2					1	2	2								
58424145	Converter Module fan(s) Y61 (Y62)				1	1							1	1					
58424153	Converter Module fan Y61						1	1							1	1			
58424163	Converter Module fan Y61							1	1									1	1
58424176	Charging resistor (1 piece) R14	1	1	1	1	1	1	2	2	2	1	1	1	1	1	2	2	2	3
58424234	Rectifier Module (1 ph. kit) V11..	3									3								
58424242	Rectifier Module (1 ph. kit) V11..		3	3								3	3						
58424251	Rectifier Module (1 ph. kit) V11..				3								3						
58424269	Rectifier Module (1 ph. kit) V11..					3	3							3	3				
58424277	Rectifier Module (1 ph. kit) V11..							3	3	3						3	3	3	
58424285	IGBT (1-phase kit incl. gate components) V1..	3	3								3	3							
58424293	IGBT (1-phase kit incl. gate components) V1..			3			6	6				3			6	6			
58424307	IGBT (1-phase kit incl. gate components) V1..				3	3			6				3	3			6		
58424315	IGBT (1-phase kit incl. gate components) V1..									6									6
58424323	Clamping diode(s) kit V1C...V6C.	1.5	1.5	1.5	1.5	1.5	3	3	3	3	1.5	1.5	1.5	1.5	1.5	3	3	3	3
58424331	DC-capacitors (2 / kit) C14..	2	2																
58424340	DC-capacitors (2 / kit) C14..			2	3	3	3	4	5	6									
58424358	DC-capacitors (3 / kit) C14..										1	2	2	2	2	3	3	4	5

*) Instead of SNAT 7902; only relevant to SAMIs manufactured before December 1992 (see serial number) and having 1400 V rectifier modules.

**SAMI
GS**

Components in Converter Modules (600 V units)

Order code	Item	ACS 504-071- 6	ACS 504-100- 6	ACS 504-120- 6	ACS 504-170- 6
61084355	Fan fuses (2 in a kit) A8:F1, F2	1	1	1	1
61081747	Main Circuit Int. Card SNAT 7266	1	1	1	1
6109xxxx	Matching Card SNAT xyzv (one per unit)	4374	4404	4421	4447
61081704	Input Protection Card SNAT 7903	1	1	1	1
61027289	Motor Control Card SNAT 7780	1	1	1	1
58424102	Current transducer (1 piece)	2	2		
58424111	Current transducer (1 piece)			2	
58424129	Current transducer (1 piece)				2
58424137	Converter Module fans Y61, Y62	2			
58424145	Converter Module fan Y61		1		
58424153	Converter Module fan Y61			1	
58424161	Converter Module fan Y61				1
58424170	Charging resistor (1 piece) R14	1	1	1	2
58424242	Rectifier Module (1 ph. kit) V11..	3			
58424269	Rectifier Module (1 ph. kit) V11..		3		
58424277	Rectifier Module (1 ph. kit) V11..			3	3
61081640	IGBT (1-phase kit incl. gate components) V1..	3	6		
61081658	IGBT (1-phase kit incl. gate components) V1..		3		6
58424323	Clamping diode(s) kit V1C. ...V6C.	1.5	1.5	3	3
58424340	DC-capacitors (2 / kit) C14..	3	3	3	5 ^{*)}

*) Total amount per unit 9 pieces

11 Technical Data

Mains Connection

Voltage U_1 :

3 phase, 380 V, 400 V and 415 V*)
3 phase, 440 V, 460 V, 480V and 500 V*)
3 phase, 575 V and 600 V*)
± 10% permitted tolerance

*) $U_{1max} = 415 \text{ V}; 500 \text{ V}; 600 \text{ V}$

Frequency f_1 : 48 ... 63 Hz

Power factor: for fundamental ≈ 0.98
total ≈ 0.95 at nominal point

Motor Connection

Output voltage U_2 : 3~, 0 ... U_1 (U_{max} at field weakening point)

Output frequency f_2 : 0 ... 120 Hz, 150 Hz

Frequency resolution: 0.01 Hz

Switching frequency: 3 kHz

Continuous output current:

Constant torque: SAMI GS rated I_N

Squared torque: SAMI GS rated I_{NSQ}

Overload capacity:

Constant torque: $1.5 * I_N$,
for 1 min every 10 min

Squared torque: $1.1 * I_{NSQ}$,
for 1 min every 10 min

Starting duty: $2.0 * I_N$ (approx. $1.4 * I_{NSQ}$) up to 20 Hz

Field weakening point: 30...180 Hz,
adjustable

Acceleration time: 1.0 to 1800 s/120 Hz

Deceleration time: 1.0 to 1800 s/120 Hz

Environmental limits

Ambient operating temperature with I_N :

0 to +40 °C

Ambient operating temperature with

I_{NSQ} :

0 to +40 °C, except
0 to +35 °C ACS 502 in IP 54 enclosure

Storage temperature: -40 to +70 °C

Cooling method: Internal fan

Corrosiveness of cooling air: up to G1
as specified in ISA-S71.04

Relative humidity: max. 95 %,
no condensation allowed

Altitude: max. 1000 m above sea level
(100 % load), 1 % derating every 100 m
above 1000 m

External control connections

Two programmable Analogue Inputs:

Voltage reference: 0(2) ... 10 V, 200 kΩ
single ended

Current reference: 0(4) ... 20 mA, 250Ω
single ended

Potentiometer reference:
10 V -0/+1 %, 10 mA

Auxiliary voltage: +24 V DC, max. 200 mA

Six programmable Digital Inputs

Two programmable Analogue Outputs

0(4) ... 20 mA, 500Ω

Three programmable Relay Outputs

max. switching voltage 300 V DC/250 V AC

max. switching current: 8 A/24 V DC,
0.4 A/250 V DC

max. switching power 2000 VA/250 V AC

max. continuous current 2 A

Serial link bus:

RS 485, ACS 500 protocol, max. 31
ACS 500 series units. Auxiliary voltage
supply for remote control panel
SAGS 700 PAN.

Protections

Overcurrent trip limit: 3.75*
 I_N instantaneously

Current regulation limit:
0.5 to 2.0 * I_N up to 37 Hz, above 1.5 * I_N

Current switch-off limit:
3.75 * I_N instantaneously

Overvoltage trip limit: 1.3 * U_{1max}

Undervoltage trip limit: 0.65 * U_N

Overtemperature limit: +85 °C heatsink

Undertemperature limit: -10 °C heatsink

Auxiliary voltage: short circuit protected

Microprocessor fault: protected

Motor stall protection

Motor overtemperature protection

**Prevention of start at earth fault
(earthed mains)**

12 Options

For brief system description and list of possible built-in options, see sections 3.1 and 3.2 of this manual.

The following options are available:

Remote control box

SACE 11 BOX, SACE 12 BOX,
SACE 20 BOX, SACE 21 BOX

A remote control box is an external control device connected to the terminal block of the Control Interface Card or an Optional Control Card.

Remote control panel

SACE 11 PAN, SACE 12 PAN

A remote control panel is an external control device connected to the terminal block of the Control Interface Card or an Optional Control Card. The panel is mounted in the operator's control desk or cubicle.

Remote control panel SAGS 700 PAN

A remote control panel can be used to control a maximum of 31 SAMI GS frequency converters, individually or all together. The panel is connected on terminal X51 to RS 485 interface. In addition to Standard Control Panel functions, the panel also has additional features such as network control, up- and down-loading of parameters (e.g. between drives) and common drive control for all connected drives. The panel functions as a master controller for bus-connected drives, but it can be set to a HOLD state where it cannot send or receive messages.

For further information please refer to the User Manual EN 5805758-4.

Input/Output Extension Card SNAT

7520 IOE

SNAT 7520 IOE is an input/output extension card with three digital and two analogue inputs, two analogue and two relay outputs.

It can be used, for example, with PFC-Control when more than 3 motors are to be controlled. In general, it can be used in applications requiring galvanically isolated inputs and outputs.

For further information please refer to the Installation and Operation Guide EN 5805784-3.

The tachometer interface includes three galvanically isolated tachometer signal channels.

The iSBX bus connector on this card enables connection of an optional ABB serial communication board (e.g. RS 232/20mA Comboard SNAT 7690).

For further information please refer to the Installation and Operation Guide EN 5805783-5.

Bus Adapter and Pulse Tachometer Interface Card SNAT 7610 BAC

SNAT 7610 BAC is a serial communication bus adapter and pulse tachometer interface card. In addition, SNAT 7610 BAC enables a speed control Application Macro to be used.

12.1 Fuse Switches and Contactors

The fuse switch (Q1) and line contactor (K1) ratings are as follows:

ACS 502- ACS 503-	Fuse Load Switch Type Q1	Fuse Load Switch Current A(AC3)	Fuse Load Switch Voltage V	Contactor Type K1	Contactor Current A(AC3)	Contactor Voltage V
051-3-/061-5-	OESA 00-160	160	660	OKYM 63W22	135	1000
061-3-/071-5-	OESA 00-160	160	660	OKYM 63W22	135	1000
071-3-/100-5-	OESA 00-160	160	660	OKYM 110W22	200	1000
100-3-/120-5-	OESA 250 D3	250	660	OKYM 110W22	200	1000
120-3-/140-5-	OESA 250 D3	250	660	OKYM 175W22	400	1000
140-3-/170-5-	OESA 400 D3	400	660	OKYM 175W22	400	1000
170-3-/210-5-	OESA 400 D3	400	660	OKYM 175W22	400	1000
210-3-/260-5-	OESA 400 D3	400	660	OKYM 6W22	600	1000
260-3-/320-5-	OESA 630 D3	630	660	OKYM 6W22	600	1000

The fuse ratings are in Table 5-1. Auxiliary contactor (K2) rating is 25 A 660 V in all cases (Type OK 0W01).

12.2 Braking Choppers and Resistors

Effective motor braking and thus short acceleration times are achieved by using a dynamic braking device, which consists of a chopper and a resistor. The Chopper is built in to the Converter Module, and there is a separate name plate for it on the left side of the Converter Module. The Resistor is assembled outside the Converter Module.

The standard ratings for the chopper and resistor are as follows:

SAMI type ACS 50x	Chopper type ACS 50x	P_{max} kW	Resistor type SAFUR...	R ohm	E_R (pulse) MJ	P_R (cont.) kW
051-3-...	SAGS 201 BR	78	80F500	6.0	2.4	6.0
061-3-...	SAGS 201 BR	78	80F500	6.0	2.4	6.0
071-3-...	SAGS 300 BR	118	125F500	4.0	3.6	9.0
100-3-...	SAGS 400 BR	118	125F500	4.0	3.6	9.0
120-3-...	SAGS 400 BR	147	200F500	2.7	5.4	13.5
140-3-...	SAGS 400 BR	147	200F500	2.7	5.4	13.5
170-3-...	SAGS 400 BR	147	200F500	2.7	5.4	13.5
210-3-...	SAGS 400 BR	147	160F415	2.4	6.0	15
260-3-...	SAGS 500 BR	155	160F415	2.4	6.0	15
061-5-...	SAGS 201 BR	114	80F500	6.0	2.4	6.0
071-5-...	SAGS 201 BR	114	80F500	6.0	2.4	6.0
100-5-...	SAGS 300 BR	171	125F500	4.0	3.6	9.0
120-5-...	SAGS 400 BR	171	125F500	4.0	3.6	9.0
140-5-...	SAGS 400 BR	171	125F500	4.0	3.6	9.0
170-5-...	SAGS 400 BR	178	200F500	2.7	5.4	13.5
210-5-...	SAGS 400 BR	178	200F500	2.7	5.4	13.5
260-5-...	SAGS 400 BR	178	200F500	2.7	5.4	13.5
320-5-...	SAGS 500 BR	185	200F500	2.7	5.4	13.5

Definitions for symbols:

- P_{max} The maximum braking power of the braking chopper (optional).
- Resistor type Type designation of the standard resistor assembly.
- R Total resistance of the standard resistor assembly. **Note!** This is also the absolute minimum value of resistance allowed for the corresponding chopper.
- E_R (pulse) Maximum energy that the standard resistor assembly will withstand. This energy will heat the resistor element from 40 °C to the maximum allowed.
- P_R (cont.) The maximum average power dissipation of the standard resistor assembly.
Note! If the energy E_R is dissipated once every 400 seconds, this rating will be fully utilised.

To increase the power rating of the resistor, four resistor assemblies should be used (two in series, two in parallel). However, it is not a standard solution and must be engineered separately.

When the chopper is active, the DC-link voltage varies in 400 V units between about 670 V and 700 V and in 500 V units between about 810 V and 845 V.

The switching frequency of the chopper varies between 0 Hz and about 500 Hz, depending on the actual braking power.

Note! The Chopper Control Card SNAT 7800 BRC inside the Converter Module has a fault relay output that is wired to the control circuit of the Rectifier bridge. Under a fault condition the trigger pulses for the rectifier thyristor will be terminated. The resistor (SAFUR...) has a thermal switch that is wired to trip the contactor in case of over-temperature.

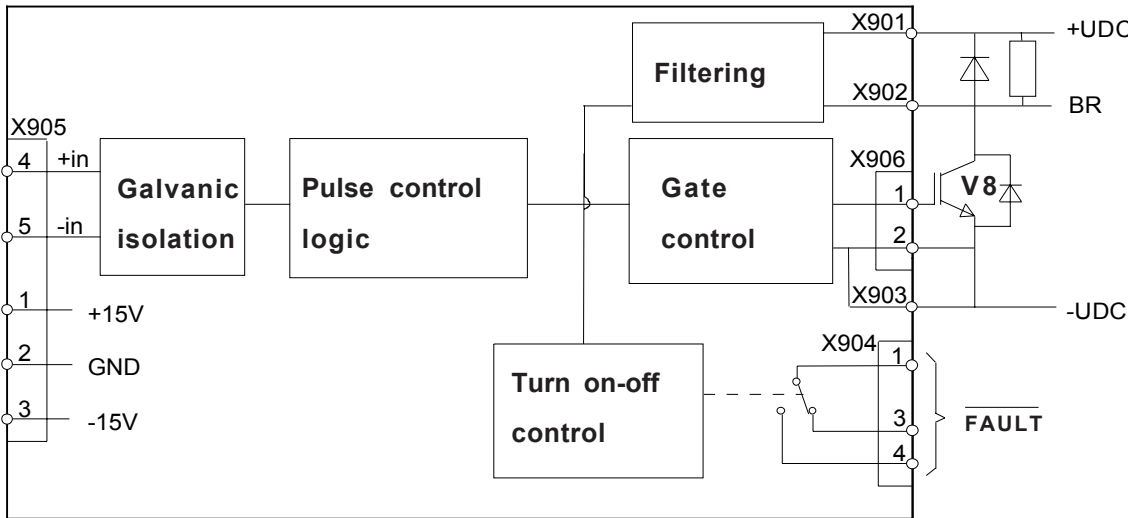

Figure 12-1 Chopper Control Card SNAT 7800 BRC.

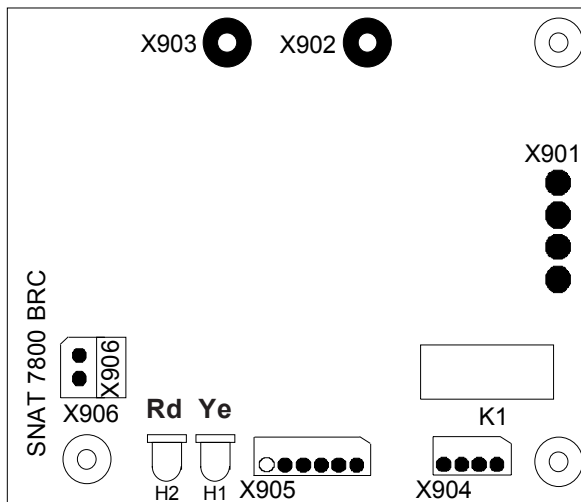

Figure 12-2 Layout SNAT 7800 BRC.

H1 = Yellow LED -> braking

H2 = Red LED -> fault

The reasons for the fault indication are:

$$U_{CE} (V8) > 15 \text{ V with on-pulse}$$

$$U_{CE} (V8) < 15 \text{ V with off-pulse}$$

A fault on the brake chopper switches the input bridge off. This may lead to an undervoltage trip on the SAMI GS. The reasons for this fault condition may be:

1. Braking resistor is missing
2. IGBT is broken
3. IGBT does not get a gate pulse

(check the cable between SNAT 7800 BRC and the IGBT).

12.3 Earth Fault Protection

The Earth Fault Protection Card SNAT 7670 EFS enables fault-current detection for both floating and earthed networks. The toroidal-core transformer T10 measures the currents at the inverter input (1000/5A). The connections for SNAT 7670 EFS are shown in Figure 12-3.

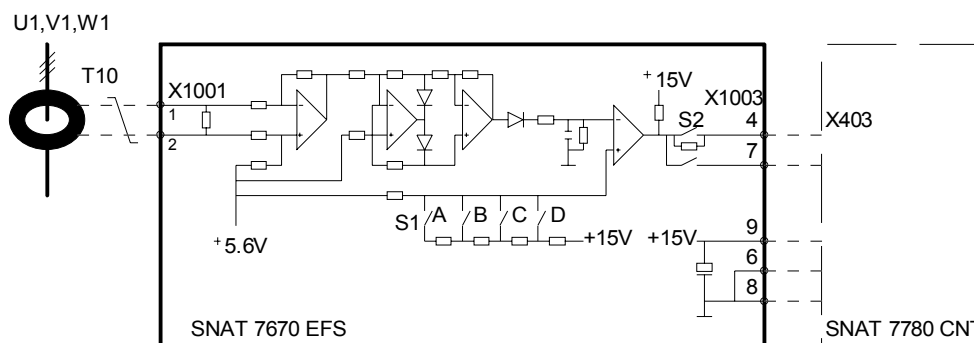
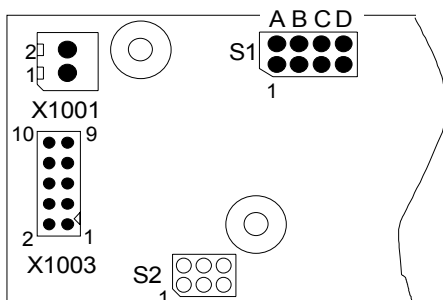

Figure 12-3. Connections of SNAT 7670 EFS.



The jumper switch S1 defines the response threshold of the system.
 S1 = open: $I_{1pp} < 2.5 \text{ A}$ most sensitive, not recommended position.
 S1 = A: $I_{1pp} > 2.5 \text{ A}$
 S1 = B: $I_{1pp} > 5.0 \text{ A}$
 S1 = C: $I_{1pp} > 7.5 \text{ A}$
 S1 = D: $I_{1pp} > 10.0 \text{ A}$

S2 not fitted/not used

Figure 12-4. Switch setting of SNAT 7670 EFS.

12.4 RFI Filter

The RFI filter, specially designed for the ACS 503 range, is connected to the SAMI GS input terminals to minimise radio frequency interference (conductive or radiative) to nearby equipment. By using the filter the conductive interference level is below EN 55011 (CISPR 11) and VDE 0875/curve G.

It is delivered in an additional 400 mm wide cabinet situated on the left hand side (600 mm for ACS 503-210...260-3, ACS 503-260...320-5).

12.5 ACS 506

ACS 506 is a SAMI GS frequency converter with a 12 pulse rectifier which reduces the harmonic distortion caused by the unit. ACS 506 is available as an IP 00 module including a rectifier module, a converter module and DC chokes. ACS 506 is available only in 400 V range and can be equipped with the same option cards as ACS 504.

For further information, contact ABB sales representative.

13 Glossary

Brake control

If the deceleration time (Group 21) is set very short and the motor load has high inertia, the DC bus voltage will rise too high causing an overvoltage trip during braking. If the deceleration time cannot be set longer, an optional brake control device (dynamic braking device) must be used.

DC bus

Intermediate DC link where the mains voltage is rectified and filtered. The nominal DC bus voltage corresponds to $1.35 * U_1$.

Default

Value provided for a parameter as a part of the program when the drive is initiated (= factory setting).

EEPROM

Electrically Erasable Programmable Read Only Memory. Memory that can be changed with an electrical signal, but retains the data when power is removed. The parameters and the control programs are stored in the EEPROM.

Field weakening point

Refer to page 60.

IR compensation

Refer to page 60.

Joystick control

Refer to page 41.

Living zero

Setting the minimum value of an Analogue Input to 4 mA (2 V) provides the operator with a "living zero" function. The existence of a control signal can then be supervised by setting the parameter 32.2 AI <2V/4mA FUNC to WARNING or FAULT, which causes a warning/fault indication when the input is less than 4 mA (2 V).

Memory

Place where data and instructions are stored for use by the program.

Parameter

A memory address that is used to store data for use by the program. The complete table of parameters is presented on pages 35-38.

Slip compensation

Refer to page 61.

Index

A

ACC	36, 50
ACS 500	
ACS 501	6
ACS 502..504	6
AI1	21, 43
AI2	21, 43
Analogue Input	21
Analogue Output	44, 46
AO	46
Application	25, 33
Autochange function	63, 65
Automatic Fault Reset	72
Auxiliary voltage	87, 88

B

Bearing wear	52
Bit Rate	48
Braking Chopper	58, 90
Bypass	63, 66

C

Cabinet	18
Charging	15
Constant Frequency	53
Constant speed	42
Contactors	89
Control	29
Control cables	22
Control Interface	11
Control Interface Card	
Program version	72
Control Panel	24, 26
Control Place	27, 30
Control Unit	10, 11, 13
Converter Module	10
Cooling	17
Critical frequency	52
Current limitation	51

D

Dangerous voltage	20
DC Holding	57
DEC	36, 50
Definitions for symbols	90
Direction	42

Discharged	16
Discharging	16
Display contrast	27
Documentation	7
Dynamic Braking	57

E

Earth leakage	80
Earthing	21
Environmental limits	87
External control	39
External control place	40
External Fan	68
External Ref	28, 41

F

Factory setting	35
Fault Function	68
Fault History Reset	74
Fault relay output	73
Fault Reset	42, 73, 75
Fault tracing	75
Field Weakening Point	59
Flying start	57
Frequency resolution	87
Fuse	
Ratings	19
Switches	89

H

Heatsink temperature	75
----------------------------	----

I

Information	38, 72
Injection braking	57
Insulation resistance	20
IR Compensation	60

J

Joystick control	41
------------------------	----

K

Keypad Ref 1	28, 30
Keypad Ref 2	28
kWh counter	28

SAMI

GS

L

Language	24, 33
LED Indication	82
Line Fuses	84
Living zero	68

M

Main Circuit Interface Card	82
Main Circuit interface	11
Mains and Motor Cables	19
Mains Connection	87
MATCHING	11
Maximum Frequency	36, 51
Minimum Frequency	36, 51
Modulator Frequency	59
Motor Connection	87
Motor Control	37
Motor Control Card program version	72
Motor Current	27
Motor load	69
Motor Power	59
Motor Speed	27
Motor Stall	68
Motor Temperature	77
Motor thermal protection	69, 70
Motor thermal times	70
Motor potentiometer	41

N

Nominal Slip	61
Normal Duty	15

O

Operating Data	27, 35
Operation hour counter	28
Optional Terminal Blocks	10
Order code	84
Overtemperature	68
Overcurrent	72
Overload capacity	87
Overvoltage	72

P

Panel operation	24
Parameter Lock	31, 43
Parameter Logic	25
Parameter storing fault	76
Part list	12
PC	49

PFC Control	37, 62
PI-Controller	36, 53
PLC	21, 22, 30, 49
Power losses	17
Power-off sequence	16
Power-on sequence	15
Protection	38, 88
Protective features	16

R

Ramp Shape	50
Reference, actual	27
Relay Output	45
Remote control box	88
Remote control panel	21, 88
Rotation direction	34
RS 232C	49
RS 485	21, 48

S

Safety precautions	31
SAMI WARNING	74
SAMI FAULT	74
SAMI GS Types	8
SAMI Output Volt	27
SAMI Temperature	18, 27
Scaling of actual value	55, 56
Serial number	83
Sleep function	62
Sleep function.	64
Slip Compensation	61
Start-Up Data	33, 35
Start/Stop	30, 40, 57
Storage	7
Supervision	67

T

Terminal sizes	19
Test date	72
Torque Boost	57
Type designation	9

U

U/f Ratio	59
Underload protection	71
Undervoltage	72

W

Wake Up function	62
------------------------	----

SAMI

GS

ACS 501	6	Motor Current	27
ACS 502..504	6	Motor Speed	27
Storage	7	Operating Data	27
Documentation	7	Reference-actual	27
SAMI GS Types	8	SAMI Output Volt	27
Type designation	9	Control Place	27
Optional Terminal Blocks	10	contrast	27
Control Unit	10	Operation hour counter	28
Converter Module	10	External Ref	28
Main Circuitinterface	11	Keypad Ref 1	28
MATCHING	11	Keypad Ref 2	28
Control Interface	11	kWh counter	28
Control Unit	11	Control	29
Display	11	PLC	30
Part list	12	Start/Stop	30
Control Unit	13	Control Place	30
Normal Duty	15	Keypad Ref 1	30
Power-on sequence	15	Parameter Lock	31
Charging	15	Safety precautions	31
Power-off sequence	16	Language	33
Protective features	16	Start-Up Data	33
discharged	16	Application	33
Discharging	16	Rotation direction	34
Power losses	17	Operating Data	35
Cooling	17	Start-Up Data	35
SAMI Temperature	18	Factory setting	35
SAMI Temperature	18	Maximum Frequency	36
Cabinet	18	Minimum Frequency	36
Mains and Motor Cables	19	PI-Controller	36
Terminal sizes	19	ACC	36
Fuse-Ratings	19	DEC	36
Dangerous voltage	20	Motor Control	37
Insulation resistance	20	PFC Control	37
RS 485	21	Protection	38
PLC	21	Information	38
Remote control panel	21	External control	39
Remote control panel	21	Start/Stop	40
Remote control panel	21	External control place	40
AI1	21	Motorpotentiometer	41
Analogue Input	21	External Ref	41
Earthing	21	Joystick control	41
PLC	22	Constant speed	42
Control cables	22	Direction	42
Language	24	Fault Reset	42
Panel operation	24	Parameter Lock	43
Control Panel	24	AI2	43
Parameter Logic	25	Analogue Output	44
Application	25	Relay Output	45
Control Panel	26	Analogue Output	46

SAMI

GS

AO	46	Underload protection	71
Bit Rate	48	Motor Control Card program version	72
PC	49	Overcurrent	72
PLC	49	Overvoltage	72
RS 232C	49	Test date	72
Ramp Shape	50	Undervoltage	72
ACC	50	Automatic Fault Reset	72
DEC	50	Programm version	72
Maximum Frequency	51	Information	72
Minimum Frequency	51	Fault relay output	73
Current limitation	51	Fault Resetting	73
Bearing wear	52	SAMI WARNING	74
Critical frequency	52	SAMI FAULT	74
PI-Controller	53	Fault History Reset	74
Constant Frequency	53	Fault Reset	75
Scaling of actual value	55	Fault tracing	75
Scaling of actual value	55	Heatsink temperature	75
Start/Stop	57	Parameter storing fault	76
Torque Boost	57	Motor Temperature	77
DC Holding	57	Earth leakage	79
Dynamic Braking	57	LED Indication	81
Flying start	57	Main Circuit Interface Card	81
Injection braking	57	Serial number	82
Brake Chopper	58	Line Fuses	83
Modulator Frequency	59	Order code	83
Motor Power	59	Mains Connection	86
U/f Ratio	59	Motor Connection	86
Field Weakning	59	Overload capacity	86
IR Compensation	60	Auxiliary voltage	86
Nominal Slip	61	Environmental limits	86
Slip Compensation	61	Frequency resolution	86
PFC Control	62	Protection	87
Sleep function	62	Remote control box	87
Wake Up function	62	Contactors	88
Autochange function	63	Switches	88
Bypass	63	Brake Chopper	89
Sleep function	64	Definitions for symbols	89
Autochange function	65
Bypass	66		
Supervision	67		
Living zero	68		
Motor Stall	68		
Over temperature	68		
External Fan	68		
Fault Function	68		
Motor load	69		
Motor thermal protection	69		
Motor thermal protection	70		
Motor thermal times	70		