

Drive^{IT}
Low Voltage
AC Drives

User's Manual
for type ACS 160 frequency
converters from 0.55 to 2.2 kW
(0.74 to 3 Hp)



ACS 160 Frequency Converter

User's Manual

3BFE 64364120 REV C
EN
Effective: 17. 5. 2002

Safety



Warning! Only a competent electrician may install the ACS 160.



Warning! Dangerous voltages are present when mains supply is connected. Wait at least 5 minutes after disconnecting the supply before removing the cover. Measure the DC voltage at terminals R+ and X4-2 before servicing the unit. (See **H**.)



Warning! Even when the motor is stopped there are dangerous voltages present at Power Circuit terminals U1, V1, W1 and U2, V2, W2.



Warning! Even when the ACS 160 is powered down, there may be dangerous external voltages at relay terminals 16 (RO1A), 17 (RO1B), 18 (RO2A), 19 (RO2B).



Warning! Never attempt to repair a broken unit; contact the supplier.



Warning! The ACS 160 will start up automatically after an input voltage interruption if the external run command is on.



Warning! When the control terminals of two or more units are connected in parallel, the auxiliary voltage for these control connections must be taken from a single source which can either be one of the units or an external supply.



Warning! The ACS 160 must not be powered up more than 3 times in 5 minutes to avoid overheating the charging resistors.



Warning! The heatsink may reach a high temperature (100 °C / 212 °F).

Note! For more technical information, contact your local ABB supplier.

Note about compatibility! The supplied ACS 160 frequency converter and this manual are compatible with the software revision 1.0.0.E and later. Positioning macro is documented as it is in software revision 1.0.0.F and later.

Table of Contents

- Safety..... iii**
- Introduction 1**
- Installation 3**
 - Step by Step Instructions for Installing the ACS 160.. 4**
 - Mounting on the Wall (ACS 163-xKx-3-D, -E, -U, -V) 4
 - Mounting on the Motor (ACS 163-xKx-3-A, -B, -R, -S) 5
 - Reference Sections 6**
 - A Environment for Storage, Transportation and Stationary Use... 6
 - B Type Designation Label and Code Key 7
 - C Motor 8
 - D Floating Network 8
 - E Mounting the Options 8
 - F Mounting the ACS 160 on the Wall..... 9
 - G Mounting the ACS 160 on Top of the Motor..... 10
 - H Terminal Interface 11
 - I Cable Entries 12
 - J Routing the Motor Cables 13
 - K Control Terminals 14
 - L Connection Examples 15
 - M Replacing the Cover 16
 - N Protection Features 16
 - O Motor Overload Protection 17
 - P Loadability of ACS 160..... 18
 - Q Type Series and Technical Data 19
 - R Product Conformity..... 20
 - S Recycling 20
 - T Options 21
- Start-up..... 23**
- Programming 27**
 - Local and Remote Control..... 27**
 - External Control Locations..... 27
 - Reference types..... 27
 - Control Panel 28**

Control Modes.....	29
Output Display	29
Menu Structure	30
Setting Parameter Value	30
Menu Functions	30
Diagnostic Displays.....	31
Resetting the Drive from the Control Panel	31
Application Macros	33
Application Macro Factory (0)	34
Application Macro Factory (1)	35
Application Macro ABB Standard.....	36
Application Macro 3-wire.....	37
Application Macro Alternate	38
Application Macro Motor Potentiometer	39
Application Macro Hand - Auto	40
Application Macro PID Control.....	41
Application Macro Premagnetise	42
Application Macro Positioning.....	43
Parameter Guide	45
ACS 160 Complete Parameter List	47
Group 99: Start-up Data.....	55
Group 01: Operating Data.....	56
Group 10: Command Inputs.....	58
Group 11: Reference Select	60
Group 12: Constant Speeds	64
Group 13: Analogue Inputs	65
Group 14: Relay Outputs	66
Group 15: Analogue Output	68
Group 16: System Controls.....	69
Group 20: Limits.....	70
Group 21: Start/Stop	71
Group 22: Accel/Decel	73
Group 25: Critical Freq.....	74
Group 26: Motor Control	75
Group 30: Fault Functions	76
Group 31: Automatic Reset.....	81
Group 32: Supervision	82
Group 33: Information	85
Group 34: Process Variables	86
Group 40: PID Control	87
Group 41: PID Control (2)	94

Group 51: Ext Comm Module	95
Group 52: Standard Modbus.....	96
Group 54: Braking (Electromechanical Brake Control)	98
Group 82: Positioning	100
Diagnostics	107
General	107
Alarm and Fault displays.....	107
Fault Resetting.....	107
Appendix A	113
Control signals	113
Appendix B	117
Dimensions	117
Motor Mounted.....	117
Wall mounted	118
Appendix C	119
EMC Instructions and Maximum Cable Lengths	119

Introduction

About this manual

The User's Manual is intended for those installing, commissioning and using the ACS 160 frequency converter. The user is expected to have basic knowledge of electrical principles and wiring practices.

This manual is divided into three parts **Installation**, **Start-up** and **Programming**. Installation part consists of Step by Step Instructions for installing the ACS 160 and of Reference Sections detailing the installation process. Start-up section gives instructions on how to commission the ACS 160. Programming part consists of sections on local and remote control, panel operation, application macros, complete parameter list and diagnostics. Control signals, dimensions and EMC instructions are appended to the back of the manual.

General overview of the ACS 160

The ACS 160 is a compact frequency converter designed for harsh environmental conditions. The strong aluminium enclosure provides IP65 protection for the control electronics.

Mounting of the ACS 160 is flexible:

- The ACS 160 can be mounted directly on the top of a TEFC (totally enclosed fan cooled) type asynchronous motor. This is done by means of a mounting kit which allows the converter to be attached to the motor terminal box.
- The ACS 160 can be mounted on a wall nearby the motor. In this case, an external fan unit is needed. The fan unit provides the necessary cooling for the converter. The control panel is provided with the wall mounted unit.

Motor mounting kits for various motors are provided as options. Custom made motor mounting kits for other motors can be designed upon request, contact your local ABB supplier for more information.

Delivery

The ACS 160 is delivered in three basic ways.

1. Wall-mounted

For mounting instructions, see Step by Step Instructions on page 4.

2. Motor-mounted

For mounting instructions, see Step by Step Instructions on page 5.

3. Drive & Motor combination

For installation instructions, refer to user documentation delivered with the unit.

Installation

Study these installation instructions carefully before proceeding. **Failure to observe the warnings and instructions given may cause a malfunction or personal hazard.**

Preparation before installation

To install the ACS 160 you need the following:

Wall mounting: screwdrivers, wire stripper, tape measure, drill, \varnothing 5 mm (0.20 in) screws, cable glands.

Motor mounting: screwdrivers, wire stripper, tape measure, drill, cable glands, 8 mm (0.31 in) wrench.

At this point it is a good idea to check the motor parameters and write them down: supply voltage (U_N), nominal current (I_N), nominal frequency (F_N), cos phi, nominal power and nominal speed.

Unpacking the unit

Check that there are no sign of damage. Before attempting installation and operation, check the information on the ACS 160 nameplate to ensure that the unit is of the correct model. (See **B**.)

Depending on the type of unit you have purchased, check that you have received all the necessary parts. The delivery package should include the unit itself, this manual and a detachable Quick Installation and Start-up Guide. The Quick Guide gives a summary of the installation instructions described here.

The **wall mounted** unit is already equipped with a wall mounting kit. For a **motor mounted** unit you will need a motor mounting kit. In addition, cable glands of appropriate sizes are needed.

To help you mark the fixing point for installation of your ACS 160 a Wall Mounting Template is included.

Step by step instructions

The installation of the ACS 160 has been broken down into a number of steps that are listed on page 4 and page 5. The steps must be carried out in the order shown. To the right of each step reference is made to one or more Reference Sections on the following pages of this User's Manual. These sections give detailed information needed for the correct installation of the unit.



Warning! Before you begin read Safety.

Step by Step Instructions for Installing the ACS 160

Mounting on the Wall (ACS 163-xKx-3-D, -E, -U, -V)

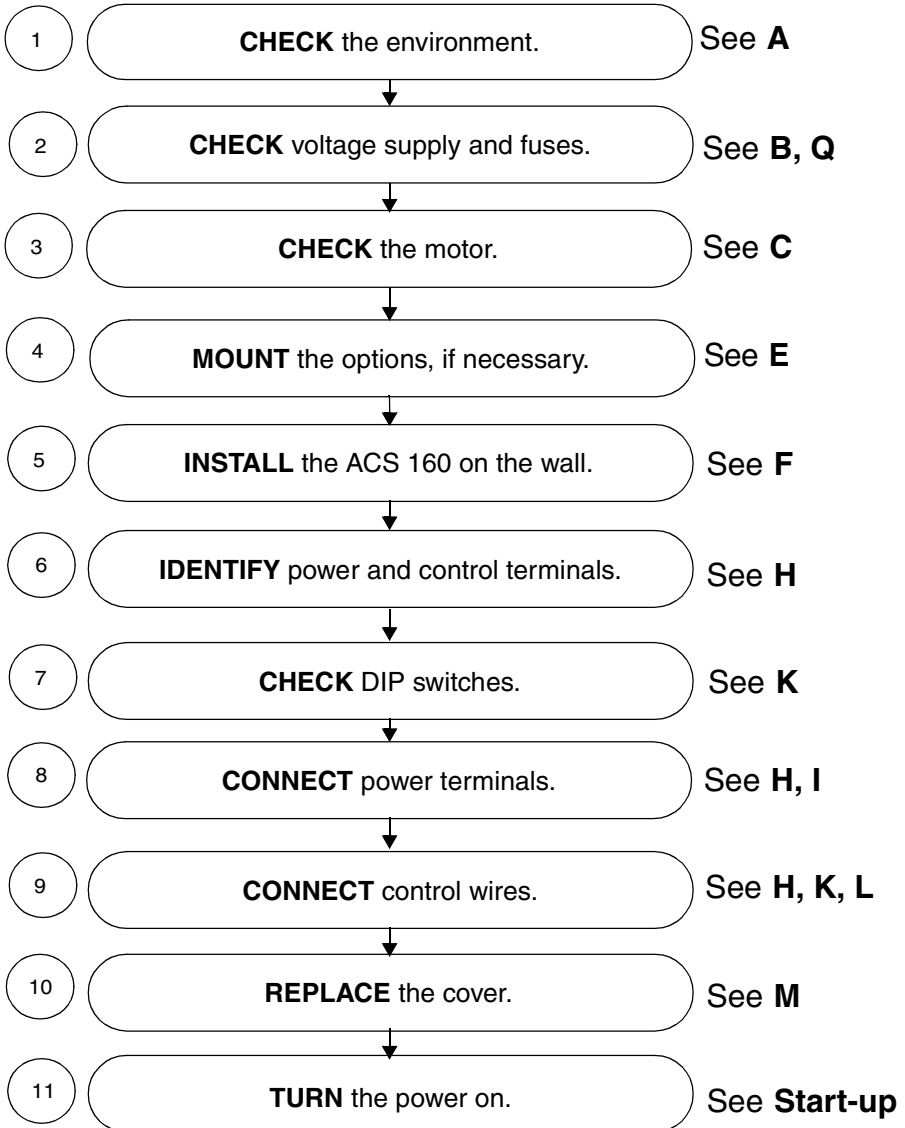

Mounting on the Motor (ACS 163-xKx-3-A, -B, -R, -S)

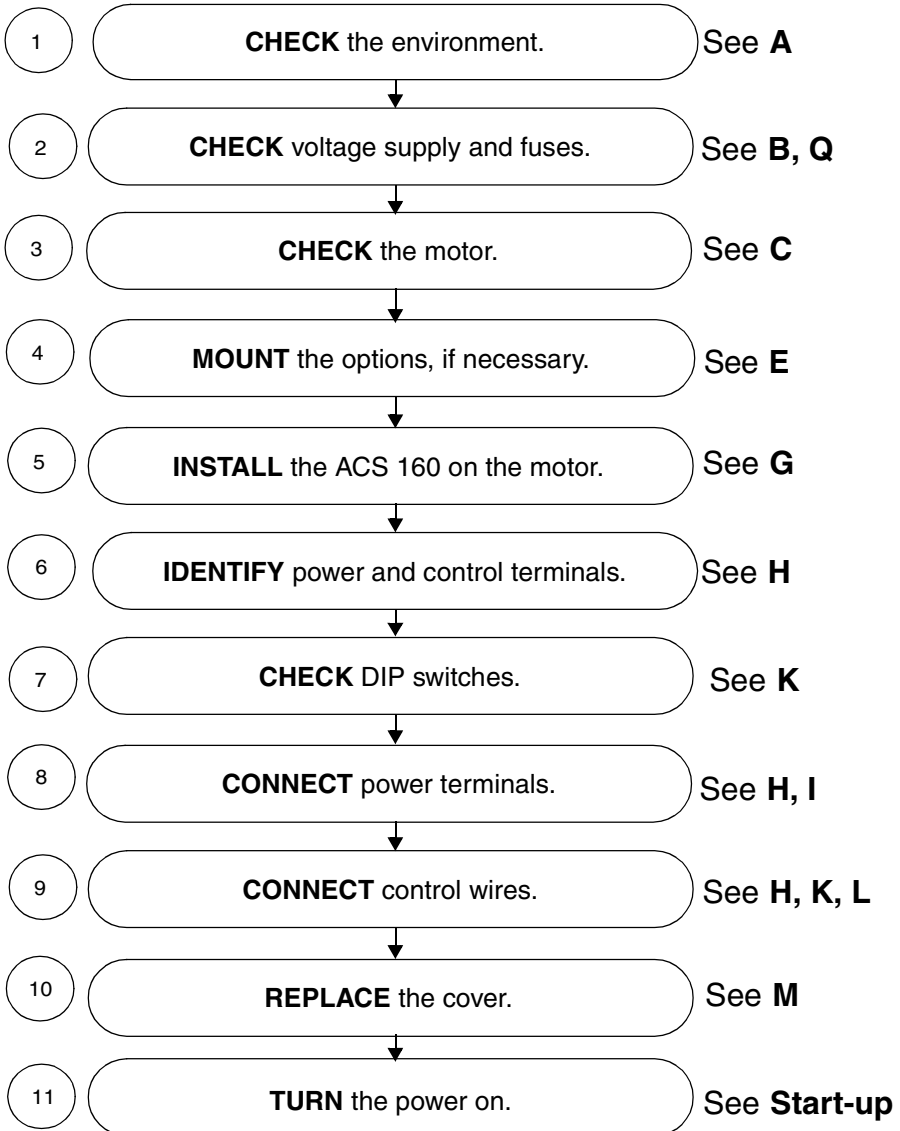



Reference Sections

A Environment for Storage, Transportation and Stationary Use

ACS 160	Stationary Use	Storage and Transportation in the protective package
Installation Site Altitude	<ul style="list-style-type: none"> 0...1000 m (0...3300 ft) if P_N and I₂ 100% 1000...2000 m (3300...6600 ft) if P_N and I₂ derated 1% every 100 m (330 ft) above 1000 m (3300 ft) 	-
Ambient Temperature	<ul style="list-style-type: none"> -10...40 °C (14...104 °F) in motor mounting 0...40 °C (32...104 °F) in wall mounting max. 50 °C (122 °F) with derating. See P. 	-40...+70 °C (-40...+158 °F)
Contamination Levels (IEC 721-3-3)	<p>According to IP65 classification</p> <ul style="list-style-type: none"> chemical gases: Class 3C3 solid particles: Class 3S3 	<p>Storage</p> <ul style="list-style-type: none"> chemical gases: Class 1C2 solid particles: Class 1S3 <p>Transportation</p> <ul style="list-style-type: none"> chemical gases: Class 2C2 solid particles: Class 2S2
Sinusoidal Vibration (IEC-721-3-3, 2 nd edition 1994-12)	<p>In motor mounting:</p> <ul style="list-style-type: none"> 2-9 Hz max amplitude 3 mm (0.118 in) 9-200 Hz max acceleration 10 m/s² (33 ft/s²) <p>In wall mounting:</p> <ul style="list-style-type: none"> 2-9 Hz max amplitude 1.5 mm (0.06 in) 9-200 Hz max acceleration 5 m/s² (16 ft/s²) 	
Shock (IEC-721-3-3, 2 nd edition 1994-12)	<p>In motor mounting:</p> <ul style="list-style-type: none"> max 250 m/s² (820 ft/s²), 6 ms <p>In wall mounting:</p> <ul style="list-style-type: none"> max 70 m/s² (230 ft/s²), 11 ms 	<ul style="list-style-type: none"> max. 300 m/s² (985 ft/s²), 18 ms
Free Fall	not allowed	<ul style="list-style-type: none"> 76 cm (30 in.), according to ISTA 1A

B Type Designation Label and Code Key

The Type Designation Label is attached on the side of the drive.

ABB Industry Oy			IP65
ACS 163-2K7-3-A			
U1 3*380...500 V	U2 3*0..U1		
f1 50/60 Hz	f2 0..250 Hz		
I1 4.5 A	I2 4.1 A		
S/N 00123456 			

Serial number:

S/N YWWRXXXX

Y = year

WW = week

R = product revision number

XXXX = internal number

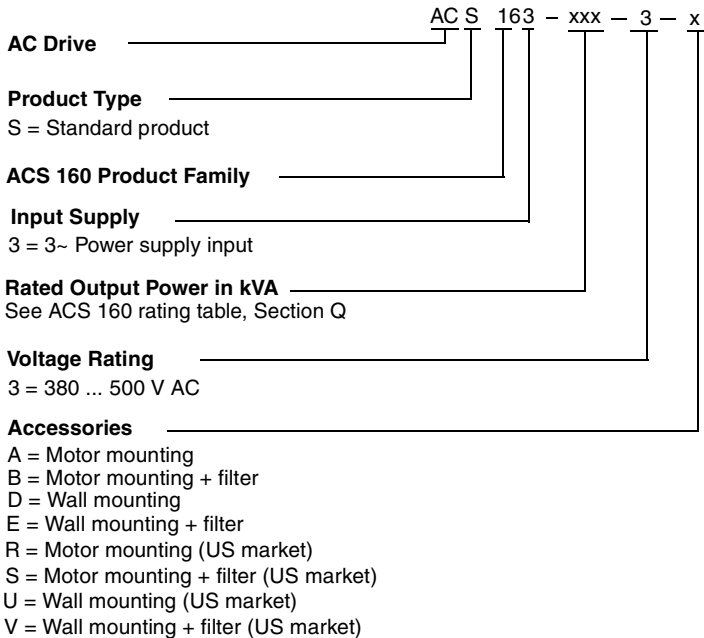

C Motor

Check the compatibility of the motor. By default, the motor must be a three-phase induction motor, with U_N from 380 to 500 V and f_N either 50 Hz or 60 Hz.

The motor nominal current (I_N), must not exceed the continuous output current (I_{2N}) of the ACS 160. See **Q**.



Warning! Ensure the motor is suitable for use with the ACS 160. The ACS 160 must be installed by a competent person. **If in doubt, contact your local ABB supplier.**

D Floating Network

In IT networks do not use units which are equipped with built-in RFI filter. The mains become connected to earth through the filter capacitors. In floating networks this may cause danger or damage the unit.

E Mounting the Options

The optional Brake resistor, Fieldbus adapter and Control panel can be attached as shown in the picture below. For more detailed instructions, see documentation delivered with the options.

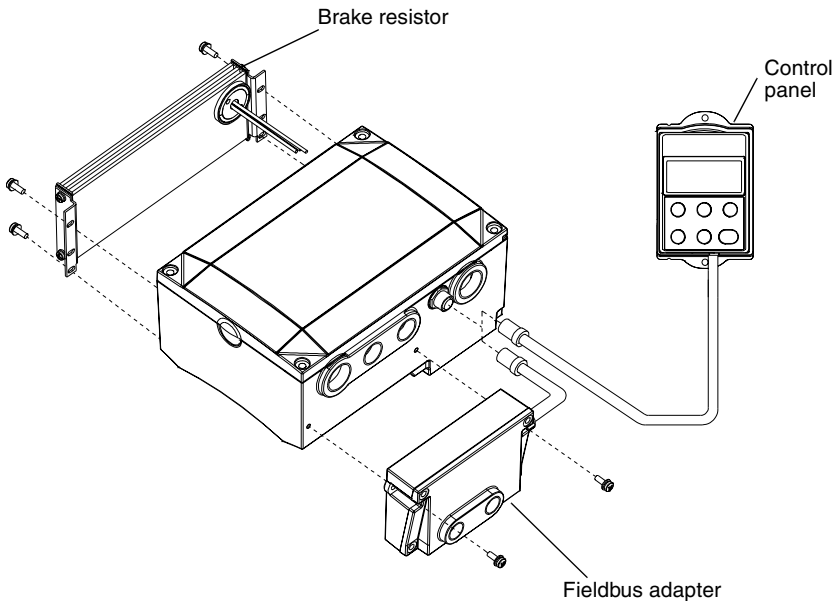

F Mounting the ACS 160 on the Wall

A Wall Mounting Template is included in the box.

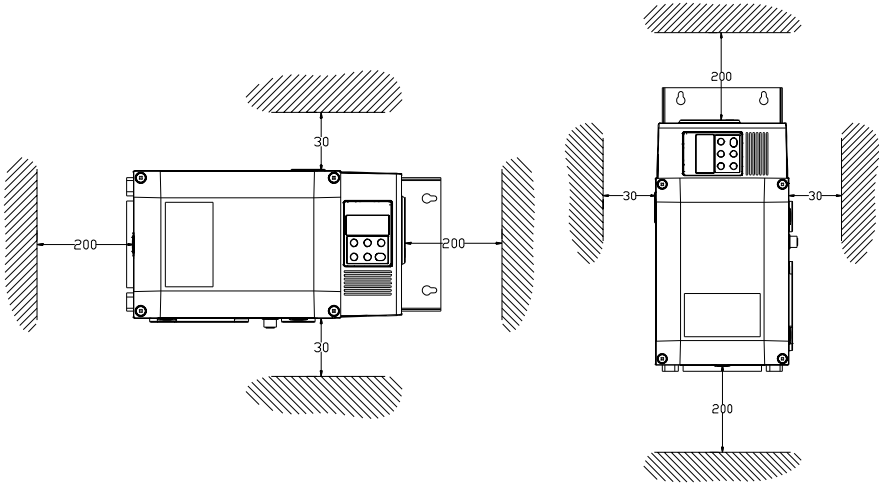
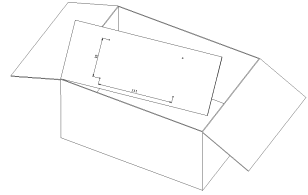

The ACS 160 should be mounted on a solid surface. **Ensure minimum air flow gaps of 200 mm (7.9 in) and 30 mm (1.18 in) as shown in the figure above.**

1. Using the mounting template in the package, mark the position of the fixing holes.
2. Drill the holes.
3. Screw in the four screws or affix the nuts and bolts (depending on the mounting surface).
4. Position the ACS 160 onto the fixings and securely tighten all four corners.



Note! Only lift the ACS 160 by its metal chassis.

G Mounting the ACS 160 on Top of the Motor

To mount the converter on the top of the motor, a motor mounting kit is required.

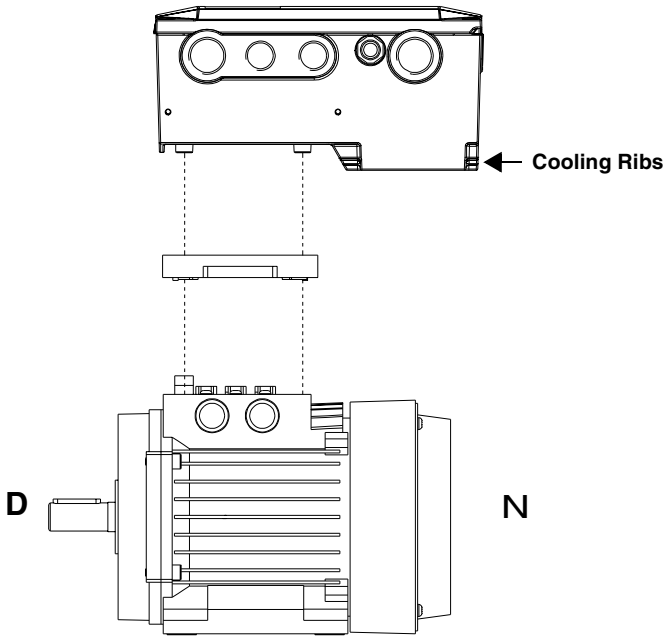

1. Connect the motor either to star or delta configuration. Check the motor rating plate.
2. Connect the motor wires to the motor terminals.
3. Connect the earthing wire to the earthing connector of the motor.
4. Mount the adapter plate following the adapter plate installation instructions delivered with the motor mounting kit.
5. Pull the wires through the converter and mount the converter.

! **Important!** The correct mounting is shown in the figure above. The cooling ribs of the ACS 160 must be located at the N-end. This is because the converter is cooled by the air flow caused by the axial fan of the motor.

Use resistance measurements to verify correct earthing of motor and converter.

Note! Make sure the motor is properly aligned with its load and firmly fastened at the foot or flange. Incorrect assembly can cause vibrations which might reduce lifetime.

If the motor has a PTC connection, parameter 3024 MOT THERM MODE must be set using the control panel.

H Terminal Interface

Use cable glands to ensure proper sealing, see I.

Note! The power supply input connectors are located in different places depending whether the unit has a built-in RFI filter or not.

Note! DC voltage can be measured between R+ and X4-2.

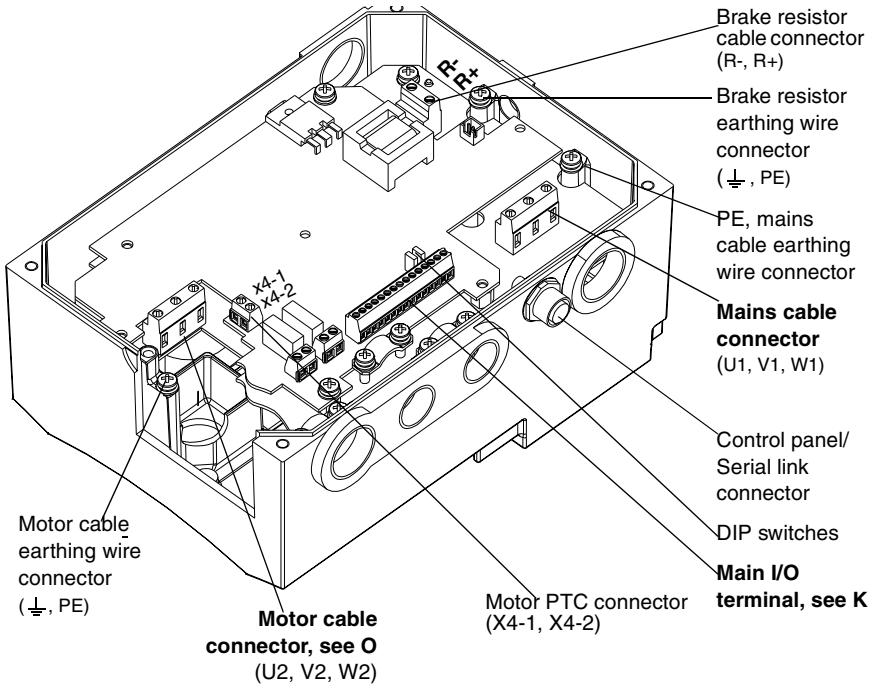

Units with built-in RFI filter

In units with built-in RFI filter, earthing wire (PE) connectors for motor and mains are located on the filter baseplate.

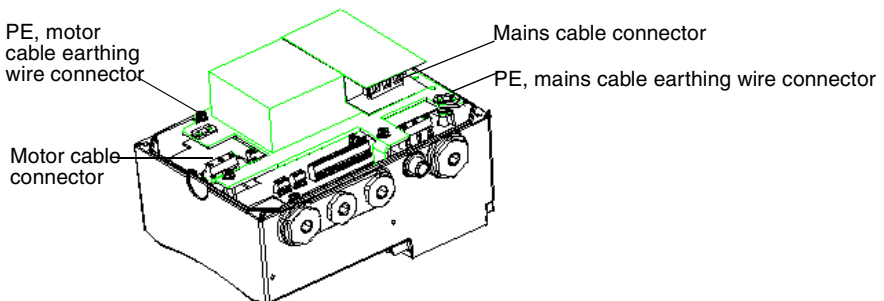

I Cable Entries

Cable glands of various sizes will be needed for the following cable entries.

Description	Thread	US Types
Motor cable entry (wall mounting)	M25	3/4" NPT plug
Relay output cable entry	M20	1/2" NPT plug
Small signal I/O cable entry	M20	1/2" NPT plug
Mains cable entry	M25	3/4" NPT plug

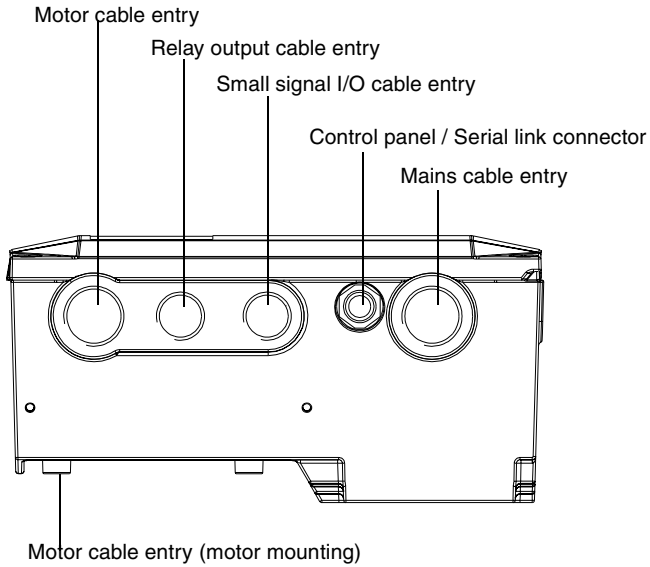

J Routing the Motor Cables

Note! The motor cable outputs are located in different places depending on whether the unit is going to be mounted on the wall or on the motor.

Wall mounting

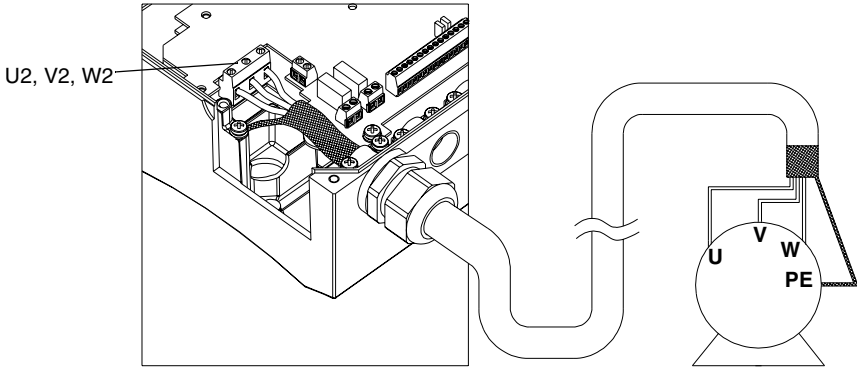

Note! For cable selection and ensuring installation compatibility with the EMC instructions, see Appendix C for EMC Instructions and Maximum Cable Lengths.

Motor mounting

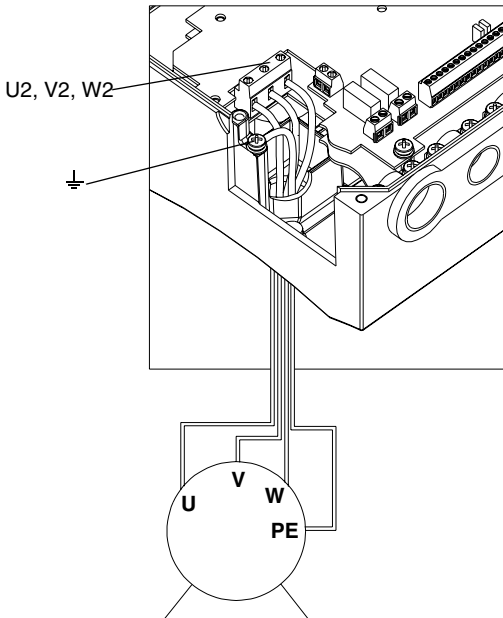

K Control Terminals

Main I/O terminal X1

Description	Identification	X1	
Terminal for signal cable screen. (Connected internally to frame earth.)	SCR	1	
Analogue input channel 1, programmable. Default: 0 - 10 V ($R_i = 200 \text{ k}\Omega$) (DIP switch:AI1 open) \Leftrightarrow 0 - f_{nom} frequency reference 0 - 20 mA ($R_i = 500 \Omega$) (DIP switch:AI1 closed) \Leftrightarrow 0 - f_{nom} frequency reference Resolution 0.1 % accuracy ± 1 %.	AI 1	2	
Analogue input circuit common. (Connected internally to frame earth through 1 M Ω)	AGND	3	
10 V/10 mA reference voltage output for analogue input potentiometer, accuracy ± 2 %.	10 V	4	
Analogue input channel 2, programmable. Default: 0 - 20 mA ($R_i = 500 \Omega$) (DIP switch:AI2 closed) \Leftrightarrow 0 - f_{nom} frequency reference 0 - 10 V ($R_i = 200 \text{ k}\Omega$) (DIP switch:AI2 open) \Leftrightarrow 0 - f_{nom} frequency reference Resolution 0.1 % accuracy ± 1 %.	AI 2	5	
Analogue input circuit common. (Connected internally to frame earth through 1 M Ω)	AGND	6	
Analogue output, programmable. Default: 0-20 mA (load < 500 Ω) \Leftrightarrow 0- f_{nom} output frequency.	AO	7	
Common for DI return signals.	AGND	8	
Auxiliary voltage output 24 V DC / 180 mA (reference to AGND). Short circuit protected.	24 V	9	
Digital input common. To activate a digital input, there must be +24 V (or -24 V) between that input and DCOM. The 24 V may be provided by the ACS 160 (X1:9) or by an external 12-24 V source of either polarity.	DCOM	10	
DI Configuration			
Factory (0)	Factory (1)		
Start/Stop. Activate to start. Motor will ramp up to frequency reference. Disconnect to stop. Motor will coast to stop.	Start. If DI 2 is activated, momentary activation of DI 1 starts the ACS 160.	DI 1	11
Reverse. Activate to reverse rotation direction.	Stop. Momentary inactivation always stops the ACS 160.	DI 2	12
Jog. Activate to set output frequency to jogging frequency (default: 5 Hz).	Reverse. Activate to reverse rotation direction.	DI 3	13
Has to be deactivated.	Has to be activated.	DI 4	14
Ramp pair selection (ACC1/DEC1 or ACC2/DEC2).		DI 5	15
Relay output 1, programmable (default: fault relay) Fault: RO1A and RO1B not connected 12 - 250 V AC / 30 V DC, 10 mA - 2 A	<input type="checkbox"/>	RO1A	16
	<input type="checkbox"/>	RO1B	17
Relay output 2, programmable (default: running) Running: RO2A and RO2B connected. 12 - 250 V AC / 30 V DC, 10 mA - 2 A	<input type="checkbox"/>	RO2A	18
	<input type="checkbox"/>	RO2B	19

Digital input impedance 1.5 k Ω .

Use multi-strand 0.5-1.5 mm² (AWG 22-16) wire.

Note! DI 4 is read only when powered-up (Factory macro 0 and 1).

Note! For fail safe reasons the fault relay signals a “fault”, when the ACS 160 is powered down.

Note! Terminals 3, 6 and 8 are at the same potential.

Note! If control panel is available, other macros can also be selected. The digital input operation depends on the selected macro.

Analogue input configuration

The analogue input signal is selected with DIP switch:

AI open = voltage input (U) and AI connected = current input (I).

Examples on selecting the analogue input signals.

Selected Signals	Scale	DIP switch
AI1 = U AI2 = I	0 - 10 V 0(4) - 20 mA	AI1: AI2:
AI1 = U AI2 = U	0 - 10 V 0 - 10 V	AI1: AI2:
AI1 = I AI2 = I	0(4) - 20 mA 0(4) - 20 mA	AI1: AI2:

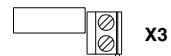
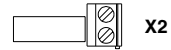
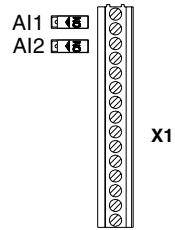

L Connection Examples

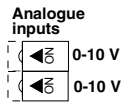
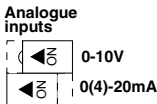

ACS 160
X1

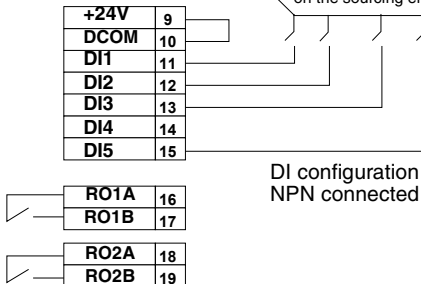
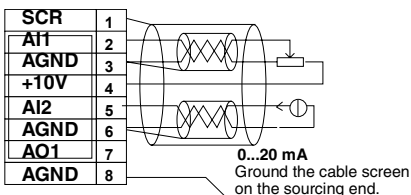

ACS 160
X1

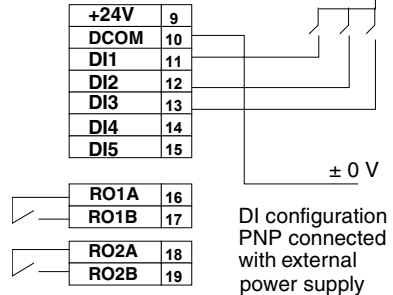
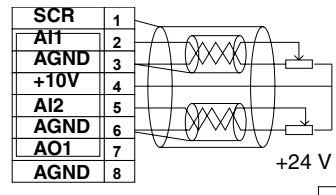

Note! These are connection examples only.

M Replacing the Cover

Do not turn the power on before replacing the cover. Make sure the grounding plug is inserted in its place.

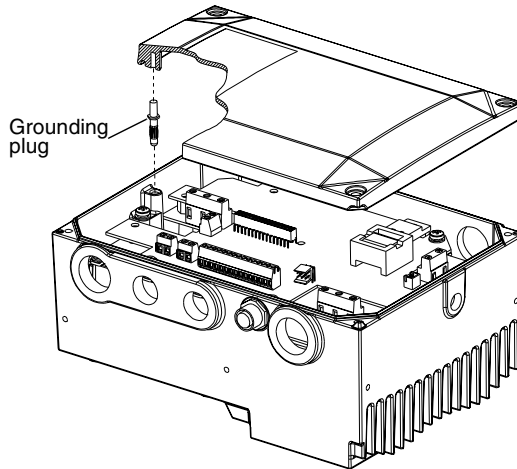

N Protection Features

The ACS 160 has a number of protective features:

- Overcurrent
- Overvoltage
- Undervoltage
- Overtemperature
- Output earth fault
- Output short circuit
- Input phase loss
- I/O terminal short circuit protection
- Motor overload protection (see **O**)
- Output overload protection (see **P**)
- Stall protection
- Underload
- Brake resistor overload protection

Note! Whenever the ACS 160 detects a fault condition, the fault relay opens. The motor stops and the ACS 160 will wait to be reset. If the fault persists and no external cause has been identified, contact your ACS 160 supplier.

O Motor Overload Protection

ACS 160 provides two ways for motor overload protection in accordance with the National Electric Code (US): software I^2t model, which is the default setting, and PTC input. For more information see Group 30: Fault Functions parameters.

If the motor current (I_{out}) from the frequency converter exceeds the motor nominal current (I_N) for a prolonged period, the ACS 160 automatically protects the motor against overheating by tripping.

The trip time depends on the extent of the overload (I_{out} / I_N), the output frequency and motor nominal frequency (f_{nom}), as shown in figure below. Times given apply to a cold start.

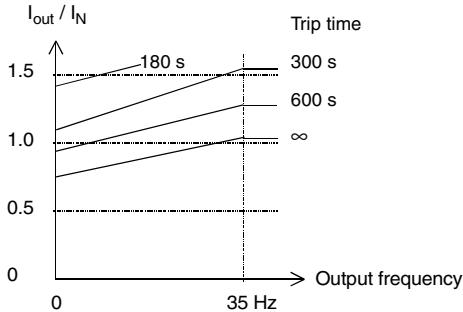

Use of motor PTC input

The motor PTC input can only be used in motor mounting. Set parameter 3024 MOT THERM MODE to 3 (THERMISTOR). When the motor PTC is used the software overload protection for the motor does not function.

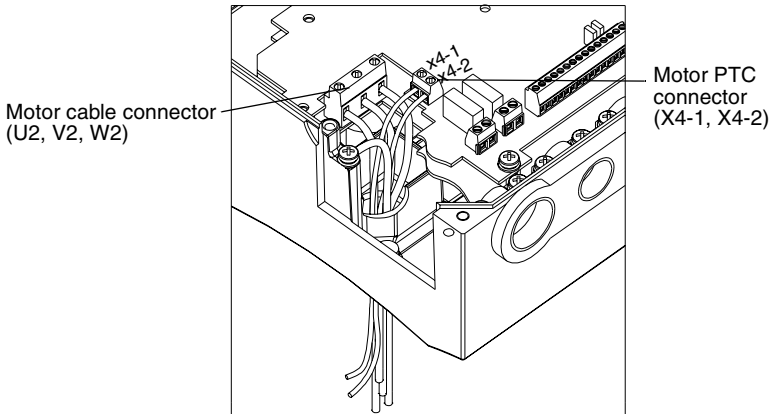

Warning! Use of motor PTC is not allowed in wall mounting because connector X4 is in main circuit potential.

Requirements for the motor PTC input cable in motor mounting are: wire size 0,5 - 1,5 mm² (22...16 AWG), temperature rating 105 °C (221 °F), and voltage rating 500 V_{rms} minimum.

P Loadability of ACS 160

Motor mounted ACS 160 types are primarily cooled by the air flow caused by the axial fan of the motor. Cooling performance of the ACS 160 is therefore dependent on the motor type and the speed at which the motor is rotating. Wall mounted ACS 160 types have a fan unit to provide constant cooling air flow for the converter

See section **Q** for continuous output current (I_{2N}) ratings.

- Loadability of the ACS 160 is 150 % * I_{2N} for 1 minute every 10 minutes.
- At starting, the loadability of the ACS 160 is 180 % * I_{2N} for 2 seconds.

In the event of overload, the ACS 160 will first indicate an alarm and then trip. Parameter 0110 ACS TEMP can be used to monitor the power module temperature.

Note! The motor should not be continuously supplied with current that is greater than the nominal current of the motor.

Normal temperature range of the ACS 160 is up to 40 °C (104 °F). With derating, using converter in up to 50 °C (122 °F) ambient is possible. Observe torque derating curves below (T/T_N , %).

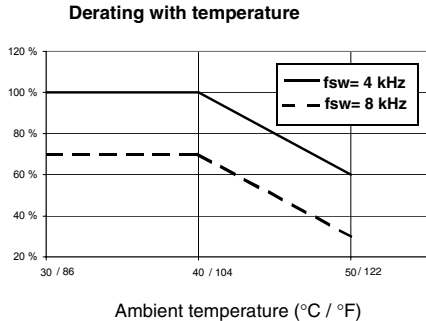
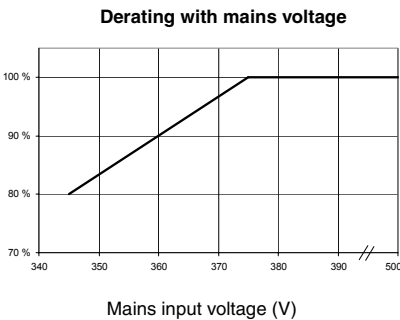

Derating with output frequency (ABB M3VA/AA, M2VA/AA, M3VRF/S and M3ARF/S motors)

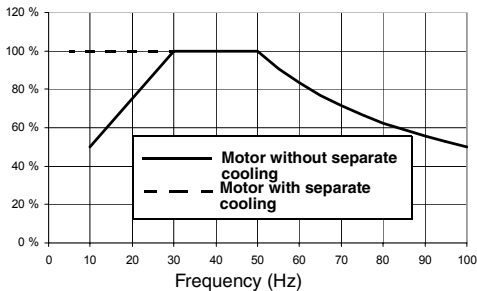

Note! The entire converter enclosure forms a cooling surface to dissipate surplus heat. Painting the converter is therefore not allowed.

If the ACS 160 drive is attached on top of motors other than specified, the allowed continuous torque ratings must be verified by thermal tests. Contact your local ABB representative for more information.

Q Type Series and Technical Data

		Motor Mounted					Wall Mounted				
Filterless 3~ Input U ₁ 380-500 V ±10 %	ACS 163-	1K1- 3-A/R	1K6- 3-A/R	2K1- 3-A/R	2K7- 3-A	4K1- 3-A/R	1K1- 3-D/U	1K6- 3-D/U	2K1- 3-D/U	2K7- 3-D	4K1- 3-D/U
Built-in filter 3~ Input U ₁ 380-480 V ±10 %	ACS 163-	1K1- 3-B/S	1K6- 3-B/S	2K1- 3-B/S	2K7- 3-B	4K1- 3-B/S	1K1- 3-E/V	1K6- 3-E/V	2K1- 3-E/V	2K7- 3-E	4K1- 3-E/V
Frame Size		R1			R2		R1			R2	
Nominal ratings (See B)											
Nominal motor P _N	kW / Hp	0.55 / 0.74	0.75 / 1	1.1 / 1.5	1.5	2.2 / 3	0.55 / 0.74	0.75 / 1	1.1 / 1.5	1.5	2.2 / 3
Input current I _{1N}	A	1.6	2.2	3.2	4.1	6.0	1.6	2.2	3.2	4.1	6.0
Continuous output current I _{2N}	A	1.8	2.4	3.4	4.1	5.4	1.8	2.4	3.4	4.1	5.4
Max. current I _{max} *	A	2.7	3.6	5.1	6.2	8.1	2.7	3.6	5.1	6.2	8.1
Max. starting current **	A	3.2	4.3	6.1	7.4	9.7	3.2	4.3	6.1	7.4	9.7
Continuous output current squared torque I _{2NSQ} ***	A	2.2	2.8	3.8	5.0	6.6	2.2	2.8	3.8	5.0	6.6
Output voltage U ₂	V	0 - U ₁									
Switching frequency f _{SW}	kHz	4 (Standard) 8 (Low noise)									
Protection limits	(See O)										
Overcurrent (peak)	A	7.1	9.5	13	16	21	7.1	9.5	13	16	21
Overvoltage: Trip limit	V DC	875									
Undervoltage: Trip limit	V DC	333									
Overtemperature	°C / (°F)	105 (221) (inside power module)									
Max. wire sizes and screw torque of connectors											
Power terminals ****	mm ²	single core: 4 (AWG 12), stranded: 2.5 (AWG 14) / torque 0.8 Nm									
Control terminals	mm ²	0.5 - 1.5 (AWG22...AWG16) / torque 0.4 Nm									
Line fuse 3~ ***** ACS163-	A	4	4	6	10	10	4	4	6	10	10
Power losses (at nominal point)											
Power circuit	W	17	23	33	45	66	17	23	33	45	66
Control circuit	W	16	17	18	19	20	18	19	20	21	22
Maximum cable lengths can be found in section EMC Instructions and Maximum Cable Lengths											

* 180 % of nominal current I_{2N}

**150 % of nominal current I_{2N}

*** **No overloadability!** Derate to 90 % when using 8 kHz switching frequency. Rating is not valid if the ACS 160 is installed on top of a non ABB motor.

**** Follow local rules for cable cross-sections. Shielded motor cable is recommended when mounting the ACS 160 on the wall.

***** Fuse type: UL class CC or T. For non-UL installations IEC269gG.

ACS 160 is suitable for use in a circuit capable of delivering not more than 65 kA rms symmetrical amperes, 500 V.

Note! Use 75 °C (167 °F) rated power cable.

R Product Conformity

CE Marking

A CE mark is attached to the ACS 160 frequency converters to verify that the unit complies with the requirements of the European

- Low Voltage Directive 73/23/EEC with amendments
- EMC Directive 89/336/EEC with amendments

Corresponding declarations and a list of main standards are available on request.



Note! See Appendix C for ACS 160 EMC Instructions.

A frequency converter and a Complete Drive Module (CDM) or a Basic Drive Module (BDM), as defined in IEC 61800-3, is not considered as a safety related device mentioned in the Machinery Directive and related harmonised standards. The CDM/BDM/frequency converter can be considered as a part of safety device if the specific function of the CDM/BDM/frequency converter fulfils the requirements of the particular safety standard. The specific function of the CDM/BDM/frequency converter and the related safety standard is mentioned in the documentation of the equipment.

UL, cUL and C-tick marking

For more information about UL, cUL and C-tick markings please contact your local ABB supplier.

S Recycling

A product to be disposed of contains valuable raw material that should be recycled, thus preserving energy and natural resources. Instructions for disposal are available from your local ABB supplier.

Both the manual and the package, which is made of corrugated cardboard, are recyclable.

T Options

Brake Resistors

CA-BRK-R1-1

Integral brake resistor for ACS 160 (0.55- 0.75 kW / 0.74-1 Hp)

CA-BRK-R1-2

Integral brake resistor for ACS 160 (1.1-1.5 kW / 1.5 Hp)

CA-BRK-R2

Integral brake resistor for ACS 160 (2.2 kW / 3 Hp)

Cable Glands

CA-MGS

Cable gland set / metric thread.

Control Panel

CA-PAN-L

Seven segment control panel with IP65 kit and 3 m (10 ft) extension cable.

Fieldbuses

CFB-PDP

Fieldbus adapter for Profibus-DP

CFB-IBS

Fieldbus adapter for Interbus-S

CFB-CAN

Fieldbus adapter for CANOpen

CFB-LON

Fieldbus adapter for LonWorks

CFB-DEV

Fieldbus adapter for DeviceNet

CFB-RS

Adapter for RS485 and RS232

Motor Mounting Kits

CMK-SIE-71-90

For Siemens 1LA7 series motors

CMK-SIE-100-112

For Siemens 1LA7 series motors

CMK-LS-71-112

For Leroy Somer LS series motors

CMK-VEM-71-112

For VEM K21R series motors

Please contact your local ABB supplier for more information about these motor mounting kits.

PC Tools

DriveWindow Light PC tool.

Start-up



The safety instructions must be followed at all times during the start-up procedure, see **Safety**.

Note! Check that starting the motor does not cause any danger.

1. Apply mains power

The first time the drive is powered up, it is controlled from the Control Terminals (remote control, **REM**).

To switch to control panel use (local control, **LOC**), press and hold the MENU and ENTER buttons down simultaneously until first **Loc** is displayed.



LOC REM

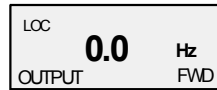

2. Check Parameters

The following parameters must be set using the information from the motor name plate (see example on right).

- 9905 MOTOR NOM VOLT
- 9906 MOTOR NOM CURR
- 9907 MOTOR NOM FREQ
- 9908 MOTOR NOM SPEED
- 9909 MOTOR NOM POWER
- 9910 MOTOR COS PHI

ABB Motors						
9612100409	Motor 3~		Cl. F IP55 IEC34			
	M2AA 080A		3GAA 082 001-ASA			
	V	Hz	r/min	kW	A	Cos φ
	380-420 Y	50	1420	0.55	1.5	0.74
220-240 D	50	1420	0.55	2.6	0.74	
440-480 Y	60	1700	0.65	1.5	0.73	

Setting parameters:

1. Press MENU to enter the Parameter Group Menu. Menu flag becomes visible.
- 2 Press UP/DOWN arrows to move between groups, select the start-up group (99).
3. Press ENTER to view individual parameters.
4. Press UP/DOWN arrows to move between parameters, select the parameter to be changed (for example 9905).
5. Press and hold ENTER until SET is displayed.
6. Use UP/DOWN arrows to alter the value.
7. Store the modified value by pressing ENTER.
8. Press MENU twice to return to OUTPUT display.

Repeat the above steps for the other parameters.

After entering the required motor data, it would be a good idea to check the other **basic parameter** settings. To see basic parameters refer to section ACS 160 Complete Parameter List (basic parameters are shaded grey in the table).

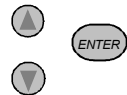
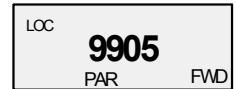
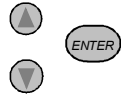
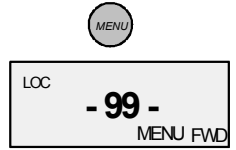

Note! Check that starting the motor does not cause any danger. If there is a risk of damage to the driven equipment in case of incorrect rotation direction of the motor, it is recommended to disengage the driven equipment when first start is performed.

3. Perform the First Start

The motor is now ready to run.

Press START/STOP button to start the motor.

To set the output frequency in local control, press ENTER. Pressing the UP/DOWN buttons changes the output immediately. Press ENTER to return to OUTPUT display.

To stop the drive press START/STOP button.



4. Check Rotation Direction

Check that the motor is running in the correct direction.

To change the rotation direction of the motor disconnect the mains power from the ACS 160 and wait 5 minutes for the intermediate circuit capacitors to discharge. Verify that the power is off.

Exchange the position of any two motor cable phase conductors at the motor terminals or at the motor connection box.

Apply the mains power and start the drive.

Rotation can also be changed from control panel by pressing the REVERSE button (parameter 1003 must be set to REQUEST).



▶ forward direction



◀ reverse direction



5. Connect the I/O Control Signals



Disconnect the mains supply of the ACS 160, and wait 5 minutes for the intermediate circuit capacitors to discharge.

Note! The unit is delivered with Factory macro 0 pre-set.

For the following instructions Factory macro 0 is selected, for all other macros refer to the section on **Application Macros**.

For analogue speed reference connect potentiometer (2-10 k Ω) to terminals 1-4.

Default setting for AI 1 is voltage.

Default motor nominal values are: 400 V, 50 Hz and 1440 rpm for unit types ACS 163-xKx-3-A, -B, -D, -E. 460 V and 60 Hz and 1750 rpm for ACS 163-xKx-3-R, -S, -U, -V type units.

6. Start the Drive from I/O

Switch on the mains.

Make sure panel display is on remote control (**REM**). If not switch to remote control by pressing MENU and ENTER simultaneously until REM is displayed.



To start the drive activate digital input DI 1 (Factory macro 0).

As default digital input DI 2 is deactivated and the rotation direction is forward. To reverse the rotation direction activate DI 2.

Output frequency is controlled by analogue input AI 1.

For further information on I/O settings, refer to the section on **Application Macros**.

7. Stop the drive from I/O

To stop the drive deactivate digital input DI 1 (Factory macro 0).

Programming

Local and Remote Control

The ACS 160 drive can be in two alternative control modes:

- In remote control mode the drive is controlled externally through the digital and analogue inputs or through serial communication. This mode is active when **REM** is visible on the control panel display.
- In local control mode the drive is controlled from the keypad of the drive's own control panel. This mode is active when **LOC** is visible on the control panel display.

User can change between local and remote control modes by pressing the MENU and ENTER buttons simultaneously.

External Control Locations

In remote control mode the drive can accept controlling commands from two alternative external locations. These external locations are called EXT1 and EXT2. In the simplest applications the drive always receives controlling commands from EXT1. The EXT2 control location is needed in complex applications like PID control.

For both external control locations it is possible to define separately from which source the drive is receiving the controlling commands (start, stop, direction and frequency reference).

For example, when controlled from external control location EXT1 the drive could receive start and stop through digital input DI1. To make this happen, parameter 1001 EXT1 COMMANDS value must be set to 1 (DI1). When controlled from external control location EXT2, the drive could receive the start/stop command through digital input DI5. Parameter 1002 EXT2 COMMANDS value must be set to 6 (DI5).

Parameter 1102 EXT1/EXT2 SEL is used to define how the drive is switched between control locations EXT1 and EXT2. As an example, by setting parameter 1102 to value 3 (DI3) causes the drive to be in EXT1 when DI3 is deactivated, and in EXT2 when DI3 is activated.

In the same way it is possible to define sources for frequency references. When external control location EXT1 is selected external reference 1 (REF1) is used. When external control location EXT2 is selected, external reference 2 (REF2) is used. Parameters 1103 EXT REF 1 SELECT and 1106 EXT REF 2 SELECT are used to select sources for the references. Source can e.g. be one of the analogue inputs or serial communication. Refer to relevant parameter descriptions for more information.

Reference types

External reference 1 and 2 have their own characteristic features:

- External reference 1 (REF1) is a frequency reference providing set point for the output frequency of the drive. This reference is always given in Hz.
- External reference 2 (REF2) is given as percentage (%). Reference 2 can be either a frequency reference or, alternatively, process reference when PID control is used. Reference 2 is internally converted to frequency so that 100 % corresponds to parameter 2008 MAXIMUM FREQ. However, when PID Control macro is used reference 2 is fed directly to the PID controller as percentage.

It should be noted that also in remote control mode references 1 and 2 can be received from the keypad if necessary. This depends on the values of parameters 1103 EXT REF1 SELECT and 1106 EXT REF2 SELECT.

In local control mode the parameter 1101 KEYPAD REF SEL is used to define which reference type (Hz or percentage) is used.

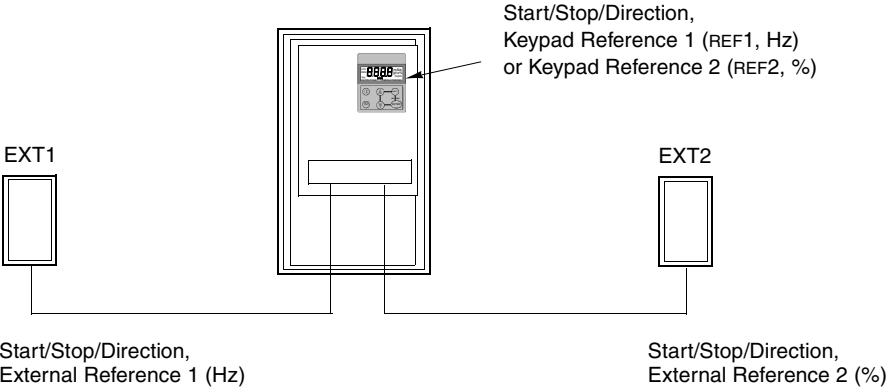
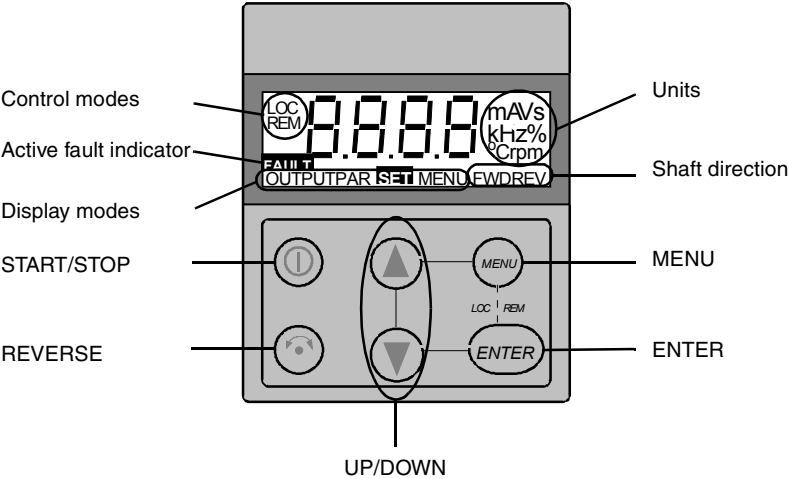

Figure 1 Control locations and reference types.

Control Panel

The control panel can be connected to and detached from the converter at any time.



Control Modes

The very first time the drive is powered up, it is controlled from the Control Terminals (remote control, **REM**). The ACS 160 is controlled from the control panel when the drive is in local control (**LOC**).

Switch to local control (**LOC**) by pressing and holding the MENU and ENTER buttons down simultaneously until first **Loc** or later **LCr** is displayed:

- If the buttons are released while **Loc** is displayed, the panel frequency reference is set to the current external reference and the drive is stopped.
- When **LCr** is displayed, the current run/stop status and the frequency reference are copied from the user I/O.

Start and stop the drive by pressing the START/STOP button.

Change the shaft direction by pressing the REVERSE button (parameter 1003 must be set to REQUEST).

Switch back to remote control (**REM**) by pressing and holding the MENU and ENTER buttons down simultaneously until **rE** is displayed.

Shaft Direction

FWD / REV Visible	<ul style="list-style-type: none">• Shaft direction is forward / reverse• Drive is running and at set point
FWD / REV Blinking rapidly	Drive is accelerating / decelerating.
FWD / REV Blinking slowly	Drive is stopped.

Output Display

When the control panel is powered up, the panel displays the actual output frequency. Whenever the MENU button is pressed and held, the control panel resumes this **OUTPUT** display.

To toggle between output frequency and output current, press the UP or DOWN button.

To set the output frequency, press ENTER. Pressing the UP/DOWN buttons changes the output immediately. Press ENTER again to return to **OUTPUT** display.

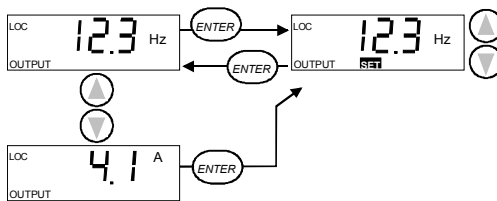

Menu Structure

ACS 160 has a large number of parameters. Of these, only the so-called **basic parameters** are initially visible. The menu function -LG- is used to make the full parameter set visible.

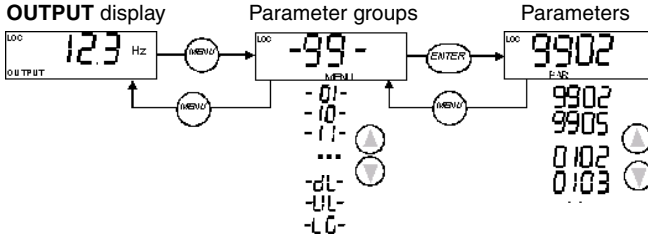

Setting Parameter Value

Press **ENTER** to view the parameter value. To set a new value, press and hold **ENTER** until **SET** is displayed.

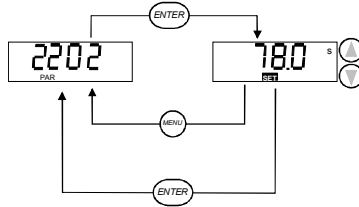

Note! **SET** blinks, if the parameter value is altered. **SET** is not displayed, if the value cannot be altered.

Note! To view the parameter default value, press the UP/DOWN buttons simultaneously.

Menu Functions

Scroll the Parameter groups for the desired menu function. Press and hold **ENTER** until the display blinks to start the function.

Select between basic and full menu

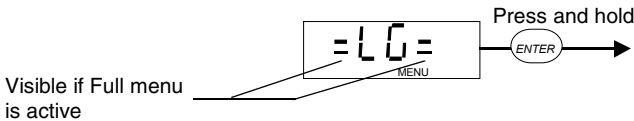

Copy parameters from drive to panel (upload)

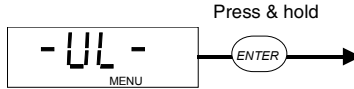

Note! Drive must be stopped and in local control. Parameter 1602 PARAMETER LOCK must be set to 1 (OPEN).

Copy parameters from panel to drive (download)

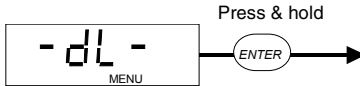

Note! Drive must be stopped and in local control. Parameter 1602 PARAMETER LOCK must be set to 1 (OPEN).

Diagnostic Displays

When a fault is active the relevant fault message flashes in the panel display.

When an alarm is active the relevant alarm message is shown in the panel display. Alarms 1-7 arise from button operation.

The alarm and fault messages disappear when MENU, ENTER or the arrow buttons of control panel are pressed. The message will reappear after a few seconds if the keypad is not touched and alarm or fault is still active.

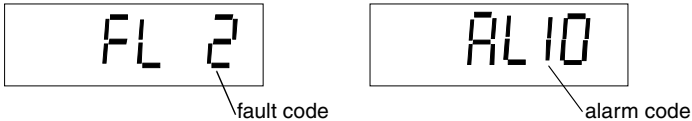

Refer to **Diagnostics** section for complete list of alarms and faults.

Resetting the Drive from the Control Panel

To reset a fault press the START/STOP button.

Caution! Resetting the fault may start the drive when in remote control.

Some faults can only be reset by turning power off. Refer to section on Diagnostics

Caution! Turning the power on again may start the drive immediately.

Application Macros

Application Macros are preprogrammed parameter sets. They minimise the number of different parameters to be set during start-up. The Factory Macro is the factory-set default macro.

Note! The Factory Macro is intended for applications where there is NO control panel available. **If using the Factory Macro with control panel note that the parameters whose value depend on the digital input DI4 cannot be modified from the panel.**

Note! Selecting an application macro with parameter 9902 APPLIC MACRO will set all other parameters to their default values, except the group 99 Start-up Data parameters, the parameter lock 1602, and groups 51 - 52 serial communication parameters.

Default values of certain parameters depend on the selected macro. These are listed with the description of each macro. Default values for other parameters are given in **ACS 160 Complete Parameter List**.

Connection Examples

In the following connection examples please note:

All the digital inputs are connected using negative (NPN) logic.

List of available macros:

1. Application Macro Factory (0)
2. Application Macro Factory (1)
3. Application Macro ABB Standard
4. Application Macro 3-wire
5. Application Macro Alternate
6. Application Macro Motor Potentiometer
7. Application Macro Hand - Auto
8. Application Macro PID Control
9. Application Macro Premagnetise
10. Application Macro Positioning

Application Macro Factory (0)

This macro is intended for applications where there is NO control panel available. It provides a general purpose 2-wire I/O configuration.

The value of parameter 9902 is 0 (FACTORY). DI4 is not connected.



Input signals

- Start, stop and direction (DI1,2)
- Analogue reference (AI1)
- Constant speed 1 (DI3)
- Ramp pair 1/2 selection (DI5)

Output signals

- An. output AO: Frequency
- Relay output 1: Fault
- Relay output 2: Running

DIP switch

- AI1:  0 - 10 V
 AI2:  0(4) - 20 mA

Connection example:

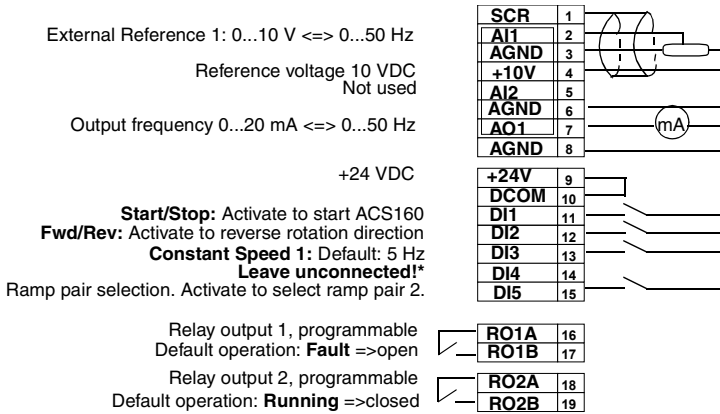

***Note!** DI 4 is used to configure ACS 160. It is read only once when power is connected. All parameters marked with * are determined by the DI4 input.

Factory (0) default parameter values:

* 1001 EXT 1 COMMANDS	2 (DI1,2)	* 1201 CONST SPEED SEL	3 (DI3)
1002 EXT 2 COMMANDS	0 (NOT SEL)	1402 RELAY OUTPUT 2	2 (RUN)
1003 DIRECTION	3 (REQUEST)	1601 RUN ENABLE	0 (NOT SEL)
1102 EXT1/EXT2 SEL	6 (EXT1)	1604 FAULT RESET SEL	6 (START/STOP)
1103 EXT REF1 SELECT	1 (AI1)	2105 PREMAGN SEL	0 (NOT SEL)
1106 EXT REF2 SELECT	0 (KEYPAD)	2201 ACC/DEC 1/2 SEL	5 (DI5)

Application Macro Factory (1)

This macro is intended for applications where there is NO control panel available. It provides a general purpose 3-wire I/O configuration.

The value of parameter 9902 is 0 (FACTORY). DI 4 is connected.

Input signals

- Start, stop and direction (DI1,2,3)
- Analogue reference (AI1)
- Ramp pair 1/2 selection (DI5)

Output signals

- An. output AO: Frequency
- Relay output 1: Fault
- Relay output 2: Running

DIP switch

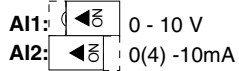

Connection example:

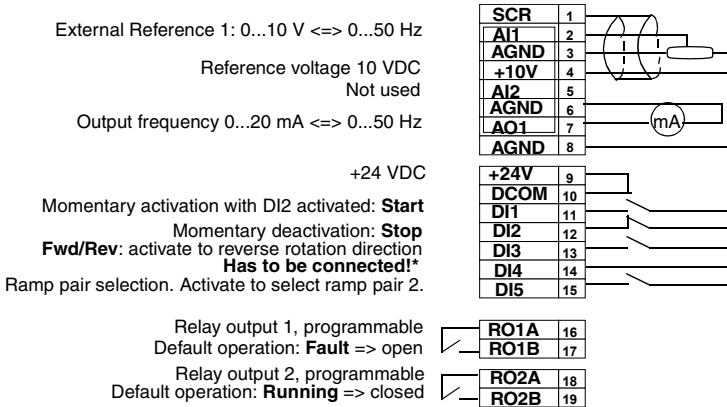

***Note!** DI 4 is used to configure ACS 160. It is read only once when power is connected. All parameters marked with * are determined by the DI4 input.

Note! Stop input (DI2) deactivated: panel START/STOP button interlocked (local).

Factory (1) default parameter values:

* 1001 EXT 1 COMMANDS	4 (DI1P, 2P, 3)	* 1201 CONST SPEED SEL	0 (NOT SEL)
1002 EXT 2 COMMANDS	0 (NOT SEL)	1402 RELAY OUTPUT 2	2 (RUN)
1003 DIRECTION	3 (REQUEST)	1601 RUN ENABLE	0 (NOT SEL)
1102 EXT1/EXT2 SEL	6 (EXT1)	1604 FAULT RESET SEL	6 (START/STOP)
1103 EXT REF1 SELECT	1 (AI1)	2105 PREMAGN SEL	0 (NOT SEL)
1106 EXT REF2 SELECT	0 (KEYPAD)	2201 ACC/DEC 1/2 SEL	5 (DI5)

Application Macro ABB Standard

This general purpose macro is typical 2-wire I/O configuration. It gives two more preset speeds compared to Factory Macro (0).

The value of parameter 9902 is 1 (ABB STANDARD).

Input signals

- Start, stop and direction (DI1,2)
- Analogue reference (AI1)
- Preset speed selection (DI3,4)
- Ramp pair 1/2 selection (DI5)

Output signals

- An. output AO: Frequency
- Relay output 1: Fault
- Relay output 2: Running

DiP switch

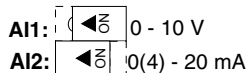

Connection Example:

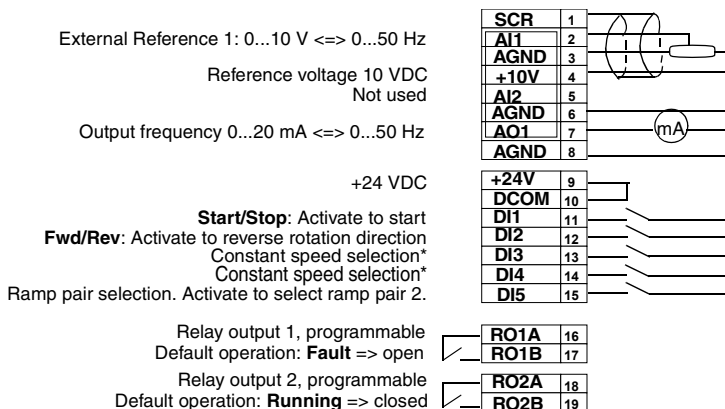

*Constant speed selection: 0 = open, 1 = connected

DI3	DI4	Output
0	0	Reference through AI1
1	0	Const speed 1 (1202)
0	1	Const speed 2 (1203)
1	1	Const speed 3 (1204)

ABB Standard default parameter values:

1001 EXT 1 COMMANDS	2 (DI1,2)	1201 CONST SPEED SEL	7 (DI3,4)
1002 EXT 2 COMMANDS	0 (NOT SEL)	1402 RELAY OUTPUT 2	2 (RUN)
1003 DIRECTION	3 (REQUEST)	1601 RUN ENABLE	0 (NOT SEL)
1102 EXT1/EXT2 SEL	6 (EXT1)	1604 FAULT RESET SEL	0 (KEYPAD)
1103 EXT REF1 SELECT	1 (AI1)	2105 PREMAGN SEL	0 (NOT SEL)
1106 EXT REF2 SELECT	0 (KEYPAD)	2201 ACC/DEC 1/2 SEL	5 (DI5)

Application Macro 3-wire

This macro is intended for those applications where the drive is controlled using momentary push-buttons. It gives two more preset speeds compared to Factory Macro (1) by using DI4 and DI5.

The value of parameter 9902 is 2 (3-WIRE).

Input signals

- Start, stop and direction (DI1,2,3)
- Analogue reference (AI1)
- Preset speed selection (DI4,5)

Output signals

- An. output AO: Frequency
- Relay output 1: Fault
- Relay output 2: Running

DIP switch

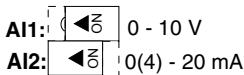

Connection example:

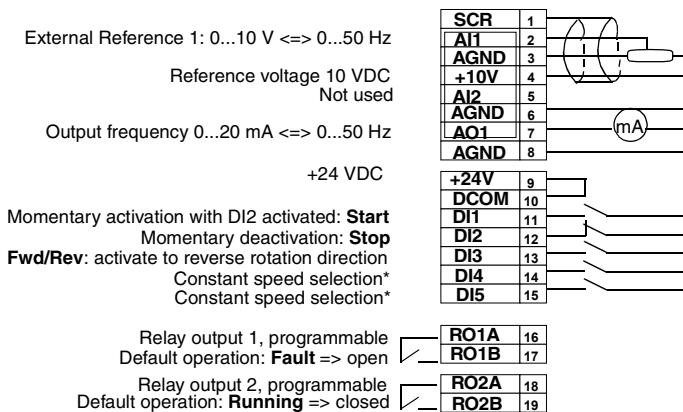

*Constant speed selection: 0 = open, 1 = connected

DI4	DI5	Output
0	0	Reference through AI1
1	0	Constant speed 1 (1202)
0	1	Constant speed 2 (1203)
1	1	Constant speed 3 (1204)

Note! Stop input (DI2) deactivated: panel START/STOP button interlocked (local).

3-wire default parameter values:

1001 EXT 1 COMMANDS	4 (DI1P,2P,3)	1201 CONST SPEED SEL	8 (DI4,5)
1002 EXT 2 COMMANDS	0 (NOT SEL)	1402 RELAY OUTPUT 2	2 (RUN)
1003 DIRECTION	3 (REQUEST)	1601 RUN ENABLE	0 (NOT SEL)
1102 EXT1/EXT2 SEL	6 (EXT1)	1604 FAULT RESET SEL	0 (KEYPAD)
1103 EXT REF1 SELECT	1 (AI1)	2105 PREMAGN SEL	0 (NOT SEL)
1106 EXT REF2 SELECT	0 (KEYPAD)	2201 ACC/DEC 1/2 SEL	0 (NOT SEL)

Application Macro Alternate

This macro offers an I/O configuration that is adopted to a sequence of DI control signals used when alternating the direction of rotation of the drive.

The value of parameter 9902 is 3 (ALTERNATE).

Input signals

- Start, stop and direction (DI1,2)
- Analogue reference (AI1)
- Preset speed selection (DI3,4)
- Ramp pair 1/2 selection (DI5)

Output signals

- An. output AO: Frequency
- Relay output 1: Fault
- Relay output 2: Running

DIP switch

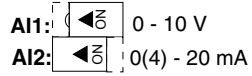

Connection example:

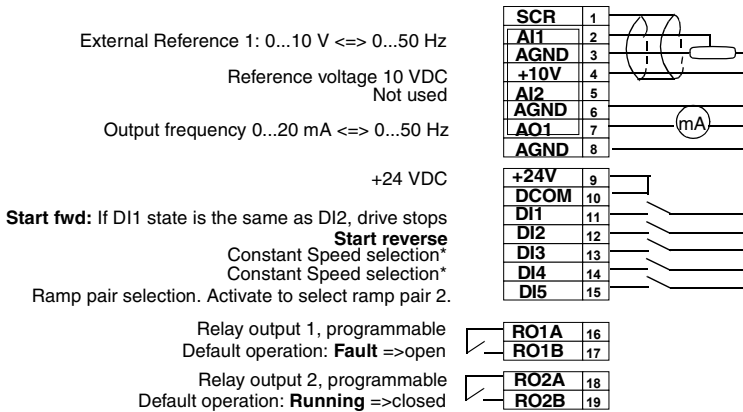

*Constant speed selection: 0 = open, 1 = connected

DI3	DI4	Output
0	0	Reference through AI1
1	0	Constant speed 1 (1202)
0	1	Constant speed 2 (1203)
1	1	Constant speed 3 (1204)

Alternate default parameter values:

1001 EXT 1 COMMANDS	9 (DI1F,2R)	1201 CONST SPEED SEL	7 (DI3,4)
1002 EXT 2 COMMANDS	0 (NOT SEL)	1402 RELAY OUTPUT 2	2 (RUN)
1003 DIRECTION	3 (REQUEST)	1601 RUN ENABLE	0 (NOT SEL)
1102 EXT1/EXT2 SEL	6 (EXT1)	1604 FAULT RESET SEL	0 (KEYPAD)
1103 EXT REF1 SELECT	1 (AI1)	2105 PREMAGN SEL	0 (NOT SEL)
1106 EXT REF2 SELECT	0 (KEYPAD)	2201 ACC/DEC 1/2 SEL	5 (DI5)

Application Macro Motor Potentiometer

This macro provides a cost-effective interface for PLCs that vary the speed of the drive using only digital signals.

The value of parameter 9902 is 4 (MOTOR POT).

Input signals

- Start, stop and direction (DI1,2)
- Reference up (DI3)
- Reference down (DI4)
- Preset speed selection (DI5)

Output signals

- An. output AO: Frequency
- Relay output 1: Fault
- Relay output 2: Running

Connection example:

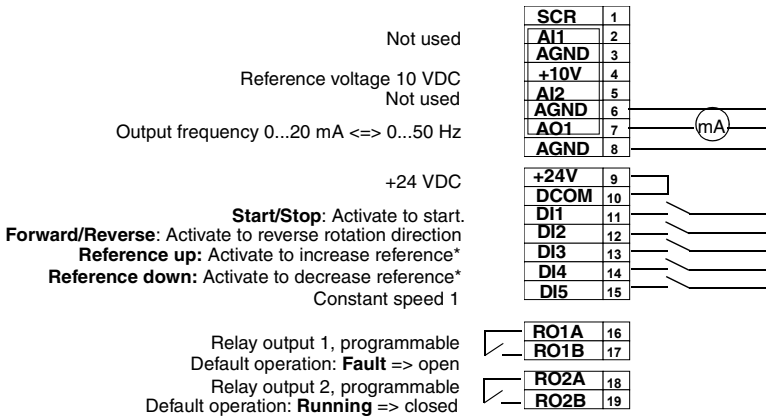

*Note!

- If both DI 3 and DI 4 are active or inactive, reference is kept stable.
- Reference is stored during stop or power down condition.
- Analogue reference is not followed when motor potentiometer is selected.

Motor potentiometer default parameter values:

1001 EXT 1 COMMANDS	2 (DI1,2)	1201 CONST SPEED SEL	5 (DI5)
1002 EXT 2 COMMANDS	0 (NOT SEL)	1402 RELAY OUTPUT 2	2 (RUN)
1003 DIRECTION	3 (REQUEST)	1601 RUN ENABLE	0 (NOT SEL)
1102 EXT1/EXT2 SEL	6 (EXT1)	1604 FAULT RESET SEL	0 (KEYPAD)
1103 EXT REF1 SELECT	6 (DI3U,4D)	2105 PREMAGN SEL	0 (NOT SEL)
1106 EXT REF2 SELECT	0 (KEYPAD)	2201 ACC/DEC 1/2 SEL	0 (NOT SEL)

Application Macro Hand - Auto

This macro offers an I/O configuration that is typically used in HVAC applications and in applications where two start/stop locations are needed.

The value of parameter 9902 is 5 (HAND/AUTO).

Input signals

- Start/stop (DI1,5) and rev (DI2,4)
- Two an. references (AI1,AI2)
- Control location selection (DI3)

Output signals

- An. output AO: Frequency
- Relay output 1: Fault
- Relay output 2: Running

DIP switch

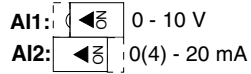

Connection example:

External Reference 1: 0...10 V \Leftrightarrow 0...50 Hz (**Hand Control**)

Reference voltage 10 VDC

External reference 2: 0...20 mA \Leftrightarrow 0...50 Hz (**Auto Control**)

Output frequency 0...20 mA \Leftrightarrow 0...50 Hz

+24 VDC

Start/Stop: Activate to start ACS 160 (**Hand**).

Forward/Reverse: Activate to reverse rotation direction (**Hand**)

EXT1/EXT2 Selection: Activate to select auto control

Forward/Reverse (Auto)

Start/Stop: Activate to start ACS 160 (**Auto**)

Relay output 1, programmable

Default operation: **Fault** \Rightarrow open

Relay output 2, programmable

Default operation: **Running** \Rightarrow closed

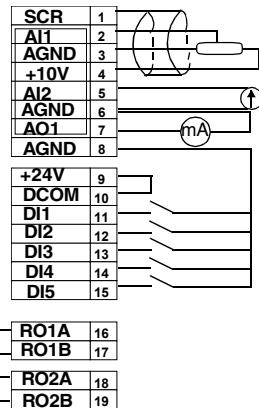

Note! Parameter 2107 START INHIBIT should be 0 (OFF).

Hand-Auto default parameter values:

1001 EXT 1 COMMANDS	2 (DI1,2)	1201 CONST SPEED SEL	0 (NOT SEL)
1002 EXT 2 COMMANDS	7 (DI5,4)	1402 RELAY OUTPUT 2	2 (RUN)
1003 DIRECTION	3 (REQUEST)	1601 RUN ENABLE	0 (NOT SEL)
1102 EXT1/EXT2 SEL	3 (DI3)	1604 FAULT RESET SEL	0 (KEYPAD)
1103 EXT REF1 SELECT	1 (AI1)	2105 PREMAGN SEL	0 (NOT SEL)
1106 EXT REF2 SELECT	2 (AI2)	2201 ACC/DEC 1/2 SEL	0 (NOT SEL)

Application Macro PID Control

This macro is intended for use with different closed-loop control systems such as pressure control, flow control, etc.

The value of parameter 9902 is 6 (PID CTRL).

Input signals

- Start/stop (DI1,5)
- Analogue reference (AI1)
- Actual value (AI2)
- Control location selection (DI2)
- Constant speed (DI3)
- Run enable (DI4)

Output signals

- An. output AO: Frequency
- Relay output 1: Fault
- Relay output 2: Running

DIP switch

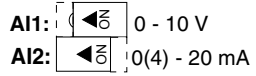

Connection example:

EXT1 (**Manual**) or EXT2 (**PID**) reference: 0...10 V

Reference voltage 10 VDC
 Actual signal; 0...20 mA (**PID**)

Output frequency 0...20 mA <=> 0...50 Hz

+24 VDC

- Start/Stop:** Activate to start ACS 160 (**Manual**).
- EXT1/EXT2 Selection:** Activate to select PID control
- Constant speed 1:** not used if PID control*
- Run enable:** deactivation always stops ACS 160
- Start/Stop:** Activate to start ACS 160 (**PID**)

Relay output 1, programmable
 Default operation: **Fault** => open

Relay output 2, programmable
 Default operation: **Running** => closed

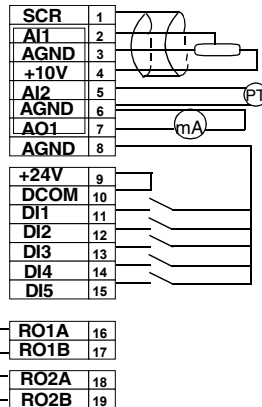

Note!

* Constant speed is not considered while in PID control (PID).

Note! Parameter 2107 START INHIBIT should be 0 (OFF).

PID control parameters (group 40) do not belong to the Basic parameter set.

PID Control default parameter values:

1001 EXT 1 COMMANDS	1 (DI1)	1201 CONST SPEED SEL	3 (DI3)
1002 EXT 2 COMMANDS	6 (DI5)	1402 RELAY OUTPUT 2	2 (RUN)
1003 DIRECTION	1 (FORWARD)	1601 RUN ENABLE	4 (DI4)
1102 EXT1/EXT2 SEL	2 (DI2)	1604 FAULT RESET SEL	0 (KEYPAD)
1103 EXT REF1 SELECT	1 (AI1)	2105 PREMAGN SEL	0 (NOT SEL)
1106 EXT REF2 SELECT	1 (AI1)	2201 ACC/DEC 1/2 SEL	0 (NOT SEL)

Application Macro Premagnetise

This macro is intended for those applications where the drive must start very quickly. Building up the flux in the motor always takes time. With the Premagnetise Macro, this delay can be eliminated.

The value of parameter 9902 is 7 (PREMAGN).

Input signals

- Start, stop and direction (DI1,2)
- Analogue reference (AI1)
- Preset speed selection (DI3,4)
- Premagnetise (DI5)

Output signals

- An. output AO: Frequency
- Relay output 1: Fault
- Relay output 2: Running

DIP switch

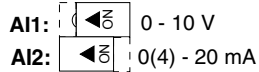

Connection example:

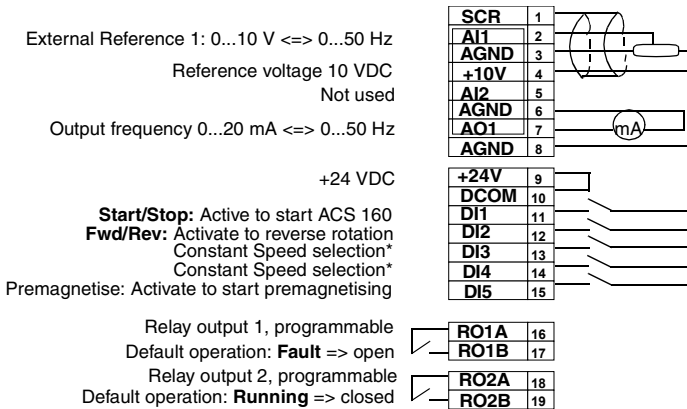

*Constant speed selection: 0 = open, 1 = connected

DI3	DI4	Output
0	0	Reference through AI1
1	0	Constant speed 1 (1202)
0	1	Constant speed 2 (1203)
1	1	Constant speed 3 (1204)

Premagnetise default parameter values:

1001 EXT 1 COMMANDS	2 (DI1,2)	1201 CONST SPEED SEL	7 (DI3,4)
1002 EXT 2 COMMANDS	0 (NOT SEL)	1402 RELAY OUTPUT 2	2 (RUN)
1003 DIRECTION	3 (REQUEST)	1601 RUN ENABLE	0 (NOT SEL)
1102 EXT1/EXT2 SEL	6 (EXT1)	1604 FAULT RESET SEL	0 (KEYPAD)
1103 EXT REF1 SELECT	1 (AI1)	2105 PREMAGN SEL	5 (DI5)
1106 EXT REF2 SELECT	0 (KEYPAD)	2201 ACC/DEC 1/2 SEL	0 (NOT SEL)

Note! Parameter 2107 START INHIBIT should be 0 (OFF).

Application Macro Positioning

This macro is intended for simple positioning tasks. The default operation is appropriate for conveyor systems where items are repetitively moved a certain distance in the same or opposite direction. Distance is measured by calculating pulses from an encoder. When the distance has been travelled i.e. desired position reached, the drive stops and waits for a new start. Simultaneously, the output relay activates signalling that target position has been reached, refer to Figure 2.

Homing is an additional configurable feature selected with parameters. Homing means that the load is driven at slow speed to known position (home position).

The value of parameter 9902 is 14 (POSITIONING).

Input signals

- Start, stop (DI1)
- Positioning/Jogging select (DI2)
- Target position select (DI3)
- Jogging reference (AI1)
- Encoder pulses (DI4 and DI5)

Output signals

- Relay output 1: Fault
- Relay output 2: Target reached

DIP switch

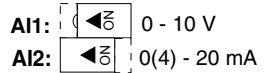

Connection example.

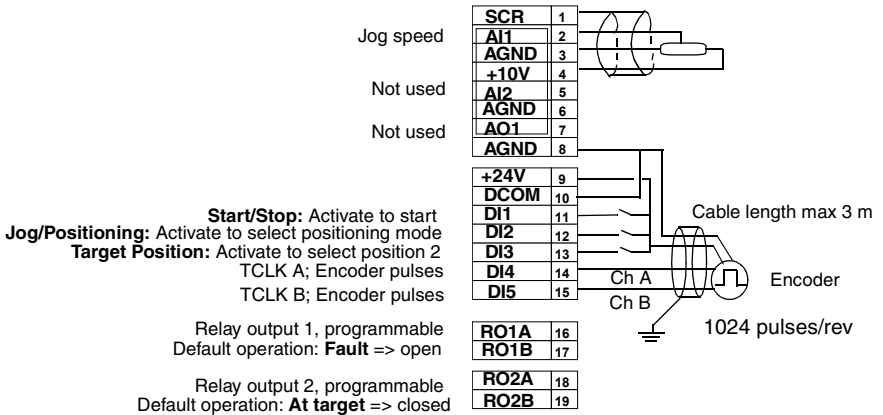

Note! After selecting the macro, turn power off and then on again.

- The encoder should be mounted on the axis of the motor.
- Use parameters 8207 - 8210 to adjust the target positions according to the application.
- Described default functionality is valid from ACS 160 SW version 1.0.0.F.

Positioning default parameter values:

1001 EXT. 1 COMMANDS	1 (DI1)	1201 COST SPEED SELL	0 (NOT SELL)
1002 EXT. 2 COMMANDS	1 (DI1)	1402 RELAY OUTPUT 2	34 (AT TARGET)
1003 DIRECTION	3 (REQUEST)	1601 RUN ENABLE	0 (NOT SELL)
1102 EXT1/EXT2 SELL	2 (DI2)	1604 FAULT RESET SELL	6 (START/STOP)
1103 EXT. REF1 SELECT	1 (AI1)	2105 PRIMING SELL	0 (NOT SELL)
1106 EXT. REF2 SELECT	1 (AI1)	2201 ACT/DEC. 1/2 SELL	0 (NOT SELL)

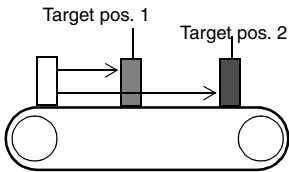
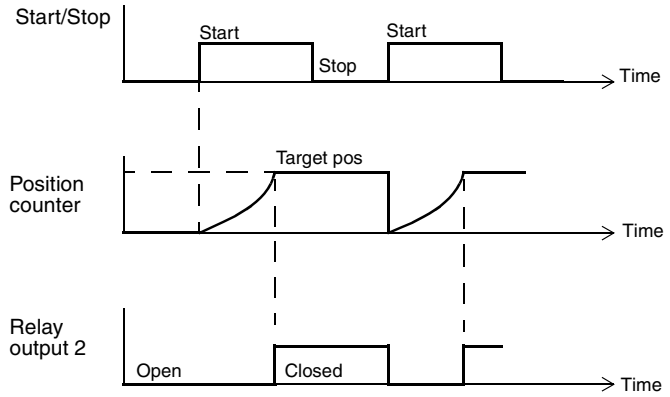

Figure 2 Default operation of the Positioning Macro when positioning is active.

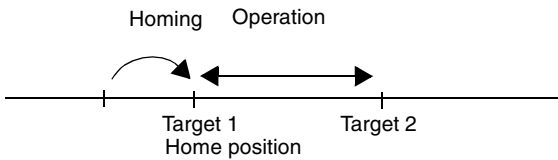

Figure 3 Example of homing operation

For separate documentation about macro positioning please contact your local ABB supplier.

Parameter Guide

	Group	Name	Description
Set-up	99	Start-up Data	Parameter settings for setting up the drive and for entering motor information.
Operating Information	01	Operating Data	Read only parameters for drive operation data, including actual signals and fault memories.
	10	Command Inputs	Parameter settings for start, stop and direction commands.
Configuration	11	Reference Select	Parameter settings for reference commands / locations.
	12	Constant Speeds	Parameter settings for constant speed value input.
	13	Analogue Input	Parameter settings for max, min and filter for the analogue input.
	14	Relay Outputs	Parameter settings for relay output characteristics.
	15	Analogue Outputs	Parameter settings for analogue output.
Performance	16	System Controls	Parameter settings for enabling/disabling parameter access, run enable etc.
	20	Limits	Parameter settings for limiting operating features and overvoltage control.
	21	Start/Stop	Parameter settings for selecting start and stop modes, flying start, torque boosting, DC hold, ramp coast etc.
	22	Acc/Decel	Parameter settings for defining the two acceleration/ deceleration ramp pairs.
	25	Critical Freq	Parameter settings for setting critical freq to avoid resonance problems.
	26	Motor Control	Parameter settings for selecting motor control features, like IR compensation and low noise u/f ratio.
	30	Fault Functions	Parameter settings for configuring desired response to certain abnormal external conditions.
Supervision	31	Automatic Reset	Parameter settings for automatically resetting some faults.
	32	Supervision	Parameter settings for any 2 parameters of group 01 to be supervised in co-operation with relays.
	33	Information	Read only parameters for information about the software version and production date.
	34	Process Variables	Parameter settings for creating custom process variables.
PID	40	PID Control	Parameter settings for the first set of PID Control parameters.
	41	PID Control (2)	Parameter settings for the second set of PID Control parameters.
Fieldbus	51	Ext Comm Module	Parameter settings for external fieldbus communication modules.
	52	Standard Modbus	Parameter settings for standard Modbus (serial communication).
Braking	54	Braking	Parameter settings for selecting additional braking features.
Positioning	81	Positioning	Parameter settings for positioning applications.

ACS 160 Complete Parameter List

Initially, only the so called basic parameters (shaded grey in the table below) are visible. Use the appropriate menu function of the control panel to make the full parameter set visible. Refer to Menu Functions.

Note! InterBus-S (CFB-IBS) and CANopen (CFB-CAN) Users: The Parameter Index equal Drive Parameter No. + 12288 converted to hexadecimal. Example: the index for drive parameter 1309 is 1309 +12288 = 13597 = 351Dh.

S = Parameters can be modified only when the drive is stopped.

M = Default value depends on the selected macro.

Code	Name	Range	Resolution	Default / US Default	Profibus par. num	User	S	M
Group 99								
START-UP DATA								
9902	APPLIC MACRO	0 - 7,14	1	0 (FACTORY)	1927		✓	
9905	MOTOR NOM VOLT	380, 400, 415, 440, 460, 480, 500 V	-	400 V / 460 V	1930		✓	
9906	MOTOR NOM CURR	0.5*I _N - 1.5*I _N	0.1 A	1.0*I _N	1931		✓	
9907	MOTOR NOM FREQ	0 - 250 Hz	1 Hz	50 Hz / 60 Hz	1932		✓	
9908	MOTOR NOM SPEED	0 - 3600 rpm	1 rpm	1440 rpm / 1750 rpm	1933		✓	
9909	MOTOR NOM POWER	0.1 - 100 kW	0.1 kW	*	1934		✓	
9910	MOTOR COS PHI	0.50 - 0.99	0.01	0.83 / 0.83	1935		✓	
Group 01								
OPERATING DATA								
0102	SPEED	0 - 9999 rpm	1 rpm	-	2			
0103	OUTPUT FREQ	0 - 250 Hz	0.1 Hz	-	3			
0104	CURRENT	-	0.1 A	-	4			
0105	TORQUE	-	0.1 %	-	5			
0106	POWER	-	0.1 kW	-	6			
0107	DC BUS VOLTAGE	0 - 999.9 V	0.1 V	-	7			
0109	OUTPUT VOLTAGE	0 - 500 V	0.1 V	-	9			
0110	ACS TEMP	0 - 150 °C	0.1 °C	-	10			
0111	EXTERNAL REF 1	0 - 250 Hz	0.1 Hz	-	11			
0112	EXTERNAL REF 2	0 - 100 %	0.1 %	-	12			
0113	CTRL LOCATION	0 - 2	1	-	13			
0114	RUN TIME (R)	0 - 9999 h	1 h	-	14			
0115	kWh COUNTER (R)	0 - 9999 kWh	1 kWh	-	15			
0116	APPL BLK OUTPUT	0 - 100 %	0.1 %	-	16			
0117	DI1-DI4 STATUS	0000 - 1111 (0 - 15 decimal)	1	-	17			
0118	AI1	0 - 100 %	0.1 %	-	18			
0119	AI2	0 - 100 %	0.1 %	-	19			
0121	DI5 & RELAYS	0000 - 0111 (0 - 7 decimal)	1	-	21			

Code	Name	Range	Resolution	Default / US Default	Profibus par. num	User	S	M
0122	AO	0 - 20 mA	0.1 mA	-	22			
0124	ACTUAL VALUE 1	0 - 100 %	0.1 %	-	24			
0125	ACTUAL VALUE 2	0 - 100 %	0.1 %	-	25			
0126	CONTROL DEV	-100 - 100 %	0.1 %	-	26			
0127	PID ACT VALUE	-100 - 100 %	0.1 %	-	27			
0128	LAST FAULT	0 - 26	1		28			
0129	PREVIOUS FAULT	0 - 26	1		29			
0130	OLDEST FAULT	0 - 26	1		30			
0131	SER LINK DATA 1	0 - 255	1		31			
0132	SER LINK DATA 2	0 - 255	1		32			
0133	SER LINK DATA 3	0 - 255	1		33			
0134	PROCESS VAR 1	-	-		34			
0135	PROCESS VAR 2	-	-		35			
0136	RUN TIME	0.00 - 99.99 kh	0.01 kh		36			
0137	MWh COUNTER	0 - 9999 MWh	1 MWh		37			
Group 10								
COMMAND INPUTS								
1001	EXT1 COMMANDS	0 - 10	1	2 / 4	101		✓	✓
1002	EXT2 COMMANDS	0 - 10	1	0	102		✓	✓
1003	DIRECTION	1 - 3	1	3	103		✓	✓
Group 11								
REFERENCE SELECT								
1101	KEYPAD REF SEL	1 - 2	1	1 (REF1 (Hz))	126			
1102	EXT1/EXT2 SEL	1 - 8	1	6	127		✓	✓
1103	EXT REF1 SELECT	0 - 13	1	1	128		✓	✓
1104	EXT REF1 MIN	0 - 250 Hz	1 Hz	0 Hz	129			
1105	EXT REF1 MAX	0 - 250 Hz	1 Hz	50 Hz / 60 Hz	130			
1106	EXT REF2 SELECT	0 - 13	1	0	131		✓	✓
1107	EXT REF2 MIN	0 - 100 %	1 %	0 %	132			
1108	EXT REF2 MAX	0 - 500 %	1 %	100 %	133			
1115	REF STEP SEL	0 - 2	1	0	140			
1117	REF STEP MODE	0 - 1	1	1	142			
1118	REF STEP UP	0 - 250 Hz 0 - 250 %	0.1 Hz 0.1 %	0 0	143			
1119	REF STEP DOWN	0 - 250 Hz 0 - 250 %	0.1 Hz 0.1 %	0 0	144			
1120	STEP DLY ON	0 - 25.0 s	0.1 s	0	145			
1121	STEP DLY OFF	0 - 25.0 s	0.1 s	0	146			
Group 12								
CONSTANT SPEEDS								
1201	CONST SPEED SEL	0 - 10	1	3 / 0	151		✓	✓
1202	CONST SPEED 1	0 - 250 Hz	0.1 Hz	5 Hz	152			
1203	CONST SPEED 2	0 - 250 Hz	0.1 Hz	10 Hz	153			

Code	Name	Range	Resolution	Default / US Default	Profibus par. num	User	S	M
1204	CONST SPEED 3	0 - 250 Hz	0.1 Hz	15 Hz	154			
1205	CONST SPEED 4	0 - 250 Hz	0.1 Hz	20 Hz	155			
1206	CONST SPEED 5	0 - 250 Hz	0.1 Hz	25 Hz	156			
1207	CONST SPEED 6	0 - 250 Hz	0.1 Hz	40 Hz	157			
1208	CONST SPEED 7	0 - 250 Hz	0.1 Hz	50 Hz	158			
Group 13								
ANALOGUE INPUTS								
1301	MINIMUM AI1	0 - 100 %	1 %	0 %	176			
1302	MAXIMUM AI1	0 - 100 %	1 %	100 %	177			
1303	FILTER AI1	0 - 10 s	0.1 s	0.1 s	178			
1304	MINIMUM AI2	0 - 100 %	1 %	0 %	179			
1305	MAXIMUM AI2	0 - 100 %	1 %	100 %	180			
1306	FILTER AI2	0 - 10 s	0.1 s	0.1 s	181			
Group 14								
RELAY OUTPUTS								
1401	RELAY OUTPUT 1	0 - 34	1	3	201			
1402	RELAY OUTPUT 2	0 - 34	1	2	202			✓
1403	RO 1 ON DELAY	0 - 3600 s	0.1 s; 1 s	0 s	203			
1404	RO 1 OFF DELAY	0 - 3600 s	0.1 s; 1 s	0 s	204			
1405	RO 2 ON DELAY	0 - 3600 s	0.1 s; 1 s	0 s	205			
1406	RO 2 OFF DELAY	0 - 3600 s	0.1 s; 1 s	0 s	206			
Group 15								
ANALOGUE OUTPUT								
1501	AO CONTENT	102 - 137	1	103	226			
1502	AO CONTENT MIN	0.0 - 999.9	0.1	0.0 Hz	227			
1503	AO CONTENT MAX	0.0 - 999.9	0.1	50.0 Hz / 60.0 Hz	228			
1504	MINIMUM AO	0.0 - 20.0 mA	0.1 mA	0 mA	229			
1505	MAXIMUM AO	0.0 - 20.0 mA	0.1 mA	20.0 mA	230			
1506	FILTER AO	0 - 10 s	0.1 s	0.1 s	231			
Group 16								
SYSTEM CONTROLS								
1601	RUN ENABLE	0 - 6	1	0	251		✓	✓
1602	PARAMETER LOCK	0 - 1	1	1 (OPEN)	252			
1604	FAULT RESET SEL	0 - 7	1	6	254		✓	✓
1605	LOCAL LOCK	0 - 1	1	0 (OPEN)	255			
1608	DISPLAY ALARMS	0-1	1	0 (NO)	258			
Group 20								
LIMITS								
2003	MAX CURRENT	0.5*I _N - 1.5*I _N **	0.1 A	1.5*I _N **	353			
2005	OVERVOLT CTRL	0 - 1	1	1 (ENABLE)	355			
2006	UNDERVOLT CTRL	0 - 2	1	1 (ENABLE TIME)	356			
2007	MINIMUM FREQ	0 - 250 Hz	1 Hz	0 Hz	357			
2008	MAXIMUM FREQ	0 - 250 Hz	1 Hz	50 Hz / 60 Hz	358		✓	

Code	Name	Range	Resolution	Default / US Default	Profibus par. num	User	S	M
Group 21								
START/STOP								
2101	START FUNCTION	1 - 4	1	1 (RAMP)	376		✓	
2102	STOP FUNCTION	1 - 2	1	1 (COAST)	377			
2103	TORQ BOOST CURR	0.5*I _N - 1.5...1.7*I _N **	0.1 A	1.2*I _N **	378		✓	
2104	STOP DC INJ TIME	0 - 250 s	0.1 s	0 s	379			
2105	PREMAGN SEL	0 - 6	1	0	380		✓	✓
2106	PREMAGN MAX TIME	0.0 - 130.0 s	0.1 s	2.0 s	381			
2107	START INHIBIT	0 - 1	1	1 (ON)	382			
Group 22								
ACCEL/DECEL								
2201	ACC/DEC 1/2 SEL	0 - 5	1	5	401		✓	✓
2202	ACCELER TIME 1	0.1 - 1800 s	0.1; 1 s	5 s	402			
2203	DECELER TIME 1	0.1 - 1800 s	0.1; 1 s	5 s	403			
2204	ACCELER TIME 2	0.1 - 1800 s	0.1; 1 s	60 s	404			
2205	DECELER TIME 2	0.1 - 1800 s	0.1; 1 s	60 s	405			
2206	RAMP SHAPE	0 - 3	1	0 (LINEAR)	406			
Group 25								
CRITICAL FREQ								
2501	CRIT FREQ SEL	0 - 1	1	0 (OFF)	476			
2502	CRIT FREQ 1 LO	0 - 250 Hz	1 Hz	0 Hz	477			
2503	CRIT FREQ 1 HI	0 - 250 Hz	1 Hz	0 Hz	478			
2504	CRIT FREQ 2 LO	0 - 250 Hz	1 Hz	0 Hz	479			
2505	CRIT FREQ 2 HI	0 - 250 Hz	1 Hz	0 Hz	480			
Group 26								
MOTOR CONTROL								
2603	IR COMPENSATION	0 - 60 V	1 V	10 V	503			
2604	IR COMP RANGE	0 - 250 Hz	1 Hz	50 Hz / 60 Hz	504			
2605	LOW NOISE	0 - 1	1	0 (OFF)	505		✓	
2606	U/f RATIO	1 - 2	1	1 (LINEAR)	506		✓	
2607	SLIP COMP RATIO	0 - 250 %	1 %	0 %	507		✓	
Group 30								
FAULT FUNCTIONS								
3001	AI<MIN FUNCTION	0 - 3	1	1 (FAULT)	601			
3002	PANEL LOSS	1 - 3	1	1 (FAULT)	602			
3003	EXTERNAL FAULT	0 - 5	1	0 (NOT SEL)	603			
3004	MOT THERM PROT	0 - 2	1	1 (FAULT)	604			
3005	MOT THERM TIME	256 - 9999 s	1 s	500 s	605			
3006	MOT LOAD CURVE	50 - 150 %	1 %	100 %	606			
3007	ZERO SPEED LOAD	25 - 150 %	1 %	70 %	607			
3008	BREAK POINT	1 - 250 Hz	1 Hz	35 Hz	608			
3009	STALL FUNCTION	0 - 2	1	0 (NOT SEL)	609			

Code	Name	Range	Resolution	Default / US Default	Profibus par. num	User	S	M
3010	STALL CURRENT	0.5*I _N - 1.5...1.7*I _N **	0.1 A	1.2* I _N **	610			
3011	STALL FREQ HI	0.5 - 50 Hz	0.1 Hz	20 Hz	611			
3012	STALL TIME	10...400 s	1 s	20 s	612			
3013	UNDERLOAD FUNC	0 - 2	1	0 (NOT SEL)	613			
3014	UNDERLOAD TIME	10...400 s	1 s	20 s	614			
3015	UNDERLOAD CURVE	1 - 5	1	1	615			
3022	AI1 FLT LIMIT	0 - 100 %	1 %	0 %	622			
3023	AI2 FLT LIMIT	0 - 100 %	1 %	0 %	623			
3024	MOT THERM MODE	2-3	1	2 (USER MODE)	624			
Group 31								
AUTOMATIC RESET								
3101	NR OF TRIALS	0 - 5	1	0	626			
3102	TRIAL TIME	1.0 - 600 s	0.1 s	30 s	627			
3103	DELAY TIME	0.0 - 120 s	0.1 s	0 s	628			
3104	AR OVERCURRENT	0 - 1	1	0 (DISABLE)	629			
3105	AR OVERVOLTAGE	0 - 1	1	0 (DISABLE)	630			
3106	AR UNDERVOLTAGE	0 - 1	1	0 (DISABLE)	631			
3107	AR AI<MIN	0 - 1	1	0 (DISABLE)	632			
Group 32								
SUPERVISION								
3201	SUPERV 1 PARAM	102 - 137	1	103	651			
3202	SUPERV 1 LIM LO	-	-	0	652			
3203	SUPERV 1 LIM HI	-	-	0	653			
3204	SUPERV 2 PARAM	102 - 137	1	103	654			
3205	SUPERV 2 LIM LO	-	-	0	655			
3206	SUPERV 2 LIM HI	-	-	0	656			
Group 33								
INFORMATION								
3301	SW VERSION	0.0.0.0 - f.f.f.f	-	-	676			
3302	TEST DATE	yy.ww	-	-	677			
Group 34								
PROCESS VARIABLES								
3402	P VAR 1 SEL	102 - 137	1	104	702			
3403	P VAR 1 MULTIP	1 - 9999	1	1	703			
3404	P VAR 1 DIVISOR	1 - 9999	1	1	704			
3405	P VAR 1 SCALING	0 - 3	1	1	705			
3407	P VAR 2 SEL	102 - 137	1	103	707			
3408	P VAR 2 MULTIP	1 - 9999	1	1	708			
3409	P VAR 2 DIVISOR	1 - 9999	1	1	709			
3410	P VAR 2 SCALING	0 - 3	1	1	710			

Code	Name	Range	Resolution	Default / US Default	Profibus par. num	User	S	M
Group 40								
PID CONTROL								
4001	PID GAIN	0.1 - 100	0.1	1.0	851			
4002	PID INTEG TIME	0; 0.1 - 600 s	0.1 s	60 s	852			
4003	PID DERIV TIME	0 - 60 s	0.1 s	0 s	853			
4004	PID DERIV FILTER	0 - 10 s	0.1 s	1 s	854			
4005	ERROR VALUE INV	0 - 1	1	0 (NO)	855			
4006	ACTUAL VAL SEL	1 - 9	1	1 (ACT1)	856			✓
4007	ACT1 INPUT SEL	1 - 2	1	2 (AI2)	857			✓
4008	ACT2 INPUT SEL	1 - 2	1	2 (AI2)	858			✓
4009	ACT1 MINIMUM	0 - 1000 %	1 %	0 %	859			
4010	ACT1 MAXIMUM	0 - 1000 %	1 %	100 %	860			
4011	ACT2 MINIMUM	0 - 1000 %	1 %	0 %	861			
4012	ACT2 MAXIMUM	0 - 1000 %	1 %	100 %	862			
4013	PID SLEEP DELAY	0.0 - 3600 s	0.1; 1 s	60 s	863			
4014	PID SLEEP LEVEL	0.0 - 120 Hz	0.1 Hz	0 Hz	864			
4015	WAKE-UP LEVEL	0.0 - 100 %	0.1 %	0 %	865			
4016	PID PARAM SET	1 - 7	1	6 (SET 1)	866			
4017	WAKE-UP DELAY	0 - 60 s	0.01 s	0.50 s	867			
4018	SLEEP SELECTION	0 - 5	1	0 (INTERNAL)	868			✓
4019	SET POINT SEL	1 - 2	1	2 (EXTERNAL)	869			
4020	INTERNAL SETPNT	0.0 - 100.0 %	0.1 %	40 %	870			
Group 41								
PID CONTROL (2)								
4101	PID GAIN	0.1 - 100	0.1	1.0	876			
4102	PID INTEG TIME	0; 0.1 - 600 s	0.1 s	60 s	877			
4103	PID DERIV TIME	0 - 60 s	0.1s	0 s	878			
4104	PID DERIV FILTER	0 - 10 s	0.1 s	1 s	879			
4105	ERROR VALUE INV	0 - 1	1	0 (NO)	880			
4106	ACTUAL VAL SEL	1 - 9	1	1 (ACT1)	881			✓
4107	ACT1 INPUT SEL	1 - 2	1	2 (AI2)	882			✓
4108	ACT2 INPUT SEL	1 - 2	1	2 (AI2)	883			✓
4109	ACT1 MINIMUM	0 - 1000 %	1 %	0 %	884			
4110	ACT1 MAXIMUM	0 - 1000 %	1 %	100 %	885			
4111	ACT2 MINIMUM	0 - 1000 %	1 %	0 %	886			
4112	ACT2 MAXIMUM	0 - 1000 %	1 %	100 %	887			
4119	SET POINT SEL	1 - 2	1	2 (EXTERNAL)	894			
4120	INTERNAL SETPNT	0.0 - 100.0 %	0.1 %	40.0 %	895			
Group 51								
EXT COMM MODULE								
5101-5115	FIELDBUSPAR1 - 15	-	-	-	1026-1040			

Code	Name	Range	Resolution	Default / US Default	Profibus par. num	User	S	M
Group 52 STANDARD MODBUS								
5201	STATION NUMBER	1 - 247	1	1	1051			
5202	COMM SPEED	3, 6, 12, 24,48, 96, 192	-	96 (9600 bits/s)	1052			
5203	PARITY	0 - 2	1	0 (NONE)	1053			
5204	COMM FAULT TIME	0.1 - .60 s	0.1 s	1 s	1054			
5205	COMM FAULT FUNC	0 - 3	1	0 (NOT SEL)	1055			
5206	BAD MESSAGES	0 - FFFF	1	-	1056			
5207	GOOD MESSAGES	0 - FFFF	1	-	1057			
5208	BUFFER OVERRUNS	0 - FFFF	1	-	1058			
5209	FRAME ERRORS	0 - FFFF	1	-	1059			
5210	PARITY ERRORS	0 - FFFF	1	-	1060			
5211	CRC ERRORS	0 - FFFF	1	-	1061			
5212	BUSY ERRORS	0 - FFFF	1	-	1062			
5213	SER FAULT MEM 1	0 - 255	1	-	1063			
5214	SER FAULT MEM 2	0 - 255	1	-	1064			
5215	SER FAULT MEM 3	0 - 255	1	-	1065			
Group 54 BRAKING								
5401	MBRK OPEN DLY	0 - 2.5 s	0.01 s	0.20 s	1087			
5403	MBRK FREQ LVL	1 - 25 Hz	0.1 Hz	2 Hz	1089			
Group 82 POSITIONING								
8201	ENC PULSE NUM	1 - 8191	1	1024	1591			
8202	ENC ERROR	0 - 1	1	0 (NOT SEL)	1592			
8203	ENC DELAY	0.1 - 60 s	0.1 s	5 s	1593			
8204	ENC SCALING	-1 ... 1	1	0	1594			
8206	POS TABLE SEL	1 - 7	1	5 (DI3)	1596			
8207	TARGET1 LO	0 - 65535	1	0	1597			
8208	TARGET1 HI	-16000 ... 16000	1	0	1598			
8209	TARGET2 LO	0 - 65535	1	0	1599			
8210	TARGET2 HI	-16000 ... 16000	1	0	1600			
8213	POS DELAY	0 - 65535	1	0	1603			
8215	POS MODE	4 - 9	1	8	1605			
8216	HOMING MODE	0 - 5	1	0	1606			
8217	AUX POS CMD	0 - 4	1	0	1607			
8218	SLOPEGAIN1	0 - 20000	1	980	1608			
8220	SPEEDGAIN1	0 - 200	1	2	1610			
8221	T WINDOW LO	0 - 65535	1	0	1611			
8222	T WINDOW HI	0 ... 16000	1	1	1612			
8223	MAX TARGET LO	0 - 65535	1	0	1613			
8224	MAX TARGET HI	0 ... 16000	1	1000	1614			

Code	Name	Range	Resolution	Default / US Default	Profibus par. num	User	S	M
8225	HOME POS LO	0 - 65535	1	0	1615			
8226	HOME POS HI	-16000 ... 16000	1	0	1616			
8227	POS ACT LO	0 - 65535	1	-	1617			
8228	POS ACT HI	-32768 ... 32767	1	-	1618			
8229	DELTA DISTANCE	0 - 200	1	2	1619			

* The motor nominal power depends on the type of unit.

** The maximum factor depending on the type of the frequency converter at 4 kHz switching frequency.

Group 99: Start-up Data

The Start-up Data parameters are a special set of parameters for setting up the ACS 160 and for entering motor information.

Code	Description
9902	<p>APPLIC MACRO Application macro selection. This parameter is used to select the Application Macro which will configure the ACS 160 for a particular application. Refer to Application Macros, for a list and description of available Application Macros.</p> <p>0 = FACTORY 2 = 3-WIRE 4 = MOTOR POT 6 = PID CONTROL 8-13 = (reserved) 1 = ABB STANDARD 3 = ALTERNATE 5 = HAND/AUTO 7 = PREMAGN 14 = POSITIONING</p>
9905	<p>MOTOR NOM VOLT Nominal motor voltage from motor rating plate. This parameter sets the maximum output voltage supplied to motor by ACS 160. MOTOR NOM FREQ sets the frequency at which output voltage is equal to the MOTOR NOM VOLT. The ACS 160 cannot supply the motor with a voltage greater than the mains voltage. See Figure 4.</p>
9906	<p>MOTOR NOM CURR Nominal motor current from rating plate. The allowed range is $0.5 \cdot I_N \dots 1.5 \cdot I_N$. Where I_N is the nominal current of the ACS 160.</p>
9907	<p>MOTOR NOM FREQ Nominal motor frequency from rating plate (field weakening point). See Figure 4.</p>
9908	<p>MOTOR NOM SPEED Nominal motor speed from rating plate.</p>
9909	<p>MOTOR NOM POWER Nominal motor power from rating plate.</p>
9910	<p>MOTOR COS PHI Nominal motor cos phi from rating plate.</p>

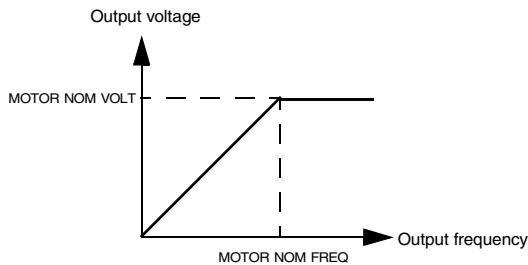
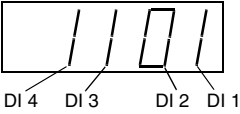
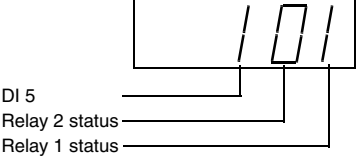

Figure 4 Output voltage as a function of output frequency.

Group 01: Operating Data

This group contains drive operating data, including actual signals and fault memories. Actual Signal values are measured or calculated by the drive and they cannot be set by the user. Fault memories can be cleared by the user from the control panel.

Code	Description
0102	SPEED Displays the calculated speed of the motor (rpm).
0103	OUTPUT FREQ Displays the frequency (Hz) applied to the motor. (Also shown in OUTPUT display.)
0104	CURRENT Displays the motor current, as measured by the ACS 160. (Also shown in OUTPUT display.)
0105	TORQUE Output torque. Calculated value of torque on motor shaft in % of motor nominal torque.
0106	POWER Displays the measured motor power in kW. Note! The control panel will not display the unit ("kW").
0107	DC BUS VOLTAGE Displays the DC bus voltage, as measured by the ACS 160. The voltage is displayed in Volts DC.
0109	OUTPUT VOLTAGE Displays the voltage applied to the motor.
0110	ACS TEMP Displays the temperature of the ACS 160 heatsink in Centigrade.
0111	EXTERNAL REF 1 The value of external reference 1 in Hz.
0112	EXTERNAL REF 2 The value of external reference 2 in %.
0113	CTRL LOCATION Displays the active control location. Alternatives are: 0 = LOCAL 1 = EXT1 2 = EXT2 See chapters Local and Remote Control and Appendix A , for description of different control locations.
0114	RUN TIME (R) Shows the total running time of the ACS 160 in hours (h). Can be reset by pressing UP and DOWN buttons simultaneously when in parameter set mode.
0115	kWh COUNTER (R) Shows the counted kilowatt hours of the ACS 160 in operation. Can be reset by pressing UP and DOWN buttons simultaneously when in parameter set mode.
0116	APPL BLK OUTPUT The reference value in per cent received from the application block. The value is from PID control. Otherwise the value is from 0112 EXT REF 2.
0117	DI1-DI4 STATUS Status of the four digital inputs. Status is displayed as a binary number. If the input is activated, the display will indicate 1. If the input is deactivated, the display will be 0. 

Code	Description
0118	AI1 Relative value of analogue input 1 displayed in %.
0119	AI2 Relative value of analogue input 2 displayed in %.
0121	DI5 & RELAYS Status of digital input 5 and relay outputs. 1 indicates that the relay is energised and 0 indicates that the relay is de-energised. 
0122	AO Value of analogue output signal in milliamperes.
0124	ACTUAL VALUE 1 PID controller actual value 1 (ACT1), displayed in per cent.
0125	ACTUAL VALUE 2 PID controller actual value 2 (ACT2), displayed in per cent.
0126	CONTROL DEV Displays the difference between the reference value and the actual value of the PID controller.
0127	PID ACT VALUE Feedback signal (actual value) for PID controller.
0128	LAST FAULT Last recorded fault (0=no fault). See Diagnostics . Can be cleared with the control panel by pressing UP and DOWN buttons simultaneously when in parameter set mode.
0129	PREVIOUS FAULT Previous recorded fault. See Diagnostics . Can be cleared with the control panel by pressing UP and DOWN buttons simultaneously when in parameter set mode.
0130	OLDEST FAULT Oldest recorded fault. See Diagnostics . Can be cleared with the control panel by pressing UP and DOWN buttons simultaneously when in parameter set mode.
0131	SER LINK DATA 1 Free data location that can be written from serial link.
0132	SER LINK DATA 2 Free data location that can be written from serial link.
0133	SER LINK DATA 3 Free data location that can be written from serial link.
0134	PROCESS VAR 1 Process variable 1, as selected by the parameters in group 34.
0135	PROCESS VAR 2 Process variable 2, as selected by the parameters in group 34.
0136	RUN TIME Shows the total running time of ACS 160 in thousands of hours (kh).
0137	MWh COUNTER Counts the megawatt hours of ACS 160 in operation.

Group 10: Command Inputs

Start, Stop and Direction commands can be given from the control panel or from two external locations (EXT1, EXT2). The selection between the two external locations is made with parameter 1102 EXT1/EXT2 SEL. For more information on control locations refer to section Local and Remote Control and Appendix A.

Code	Description
1001	<p>EXT1 COMMANDS Defines the connections and the source of Start/Stop/Direction commands for External control location 1 (EXT1).</p> <p>0 = NOT SEL No Start/Stop/Direction command source for EXT1 is selected.</p> <p>1 = DI1 Two-wire Start/Stop connected to digital input DI1. DI1 deactivated = Stop; DI1 activated = Start. *</p> <p>2 = DI1,2 Two-wire Start/Stop, Direction. Start/Stop is connected to digital input DI1 as above. Direction is connected to digital input DI2. DI2 deactivated = Forward; DI2 activated = Reverse. To control direction, value of parameter 1003 DIRECTION should be REQUEST.</p> <p>3 = DI1P,2P Three-wire Start/Stop. Start/Stop commands are given by means of momentary push-buttons (the P stands for "pulse"). The Start push-button is normally open, and connected to digital input DI1. The Stop push-button is normally closed, and connected to digital input DI2. Multiple Start push-buttons are connected in parallel; multiple Stop push-buttons are connected in series. *,**</p> <p>4 = DI1P,2P,3 Three-wire Start/Stop, Direction. Start/Stop connected as with DI1P,2P. Direction is connected to digital input DI3. DI3 deactivated = Forward; DI3 activated = Reverse. To control Direction, value of parameter 1003 DIRECTION should be REQUEST. **</p> <p>5 = DI1P,2P,3P Start Forward, Start Reverse, and Stop. Start and Direction commands are given simultaneously with two separate momentary push-buttons (the P stands for "pulse"). The Stop push-button is normally closed, and connected to digital input DI3. The Start Forward and Start Reverse push-buttons are normally open, and connected to digital inputs DI1 and DI2 respectively. Multiple Start push-buttons are connected in parallel, and multiple Stop push-buttons are connected in series. To control direction, value of parameter 1003 DIRECTION should be REQUEST. **</p> <p>6 = DI5 Two-wire Start/Stop, connected to digital input DI5. DI5 deactivated = Stop and DI5 activated = Start. *</p> <p>7 = DI5,4 Two-wire Start/Stop/Direction. Start/Stop is connected to digital input DI5. Direction is connected to digital input DI4. DI4 deactivated = Forward and DI4 activated = Reverse. To control direction, value of parameter 1003 DIRECTION should be REQUEST.</p> <p>8 = KEYPAD The Start/Stop and Direction commands are given from the control panel when External control location 1 is active. To control direction, value of parameter 1003 DIRECTION should be REQUEST.</p> <p>9 = DI1F,2R Start forward command is given when DI1= activated and DI2= deactivated. Start reverse command is given if DI1 is deactivated and DI2 is activated. In other cases Stop command is given.</p> <p>10 = COMM The Start/Stop and Direction commands are given through serial communication.</p> <p>*Note! In cases 1, 3, 6 direction is set with parameter 1003 DIRECTION. Selecting value 3 (REQUEST) fixes direction to Forward.</p> <p>**Note! Stop signal must be activated before Start command can be given.</p>

1002	EXT2 COMMANDS Defines the connections and the source of Start, Stop and Direction commands for external control location 2 (EXT2). Refer to parameter 1001 EXT1 COMMANDS above.
1003	DIRECTION 1 = FORWARD 2 = REVERSE 3 = REQUEST Rotation direction lock. This parameter allows you to fix the direction of rotation of the motor to forward or reverse. If you select 3 (REQUEST), the direction is set according to the given direction command.

Group 11: Reference Select

Reference commands can be given from the control panel or from two external locations. The selection between the two external locations is made with parameter 1102 EXT1/EXT2 SEL. For more information on control locations, refer to section Local and Remote Control and Appendix A

Code	Description
1101	KEYPAD REF SEL Selection of active control panel reference in local control mode. 1 = REF1 (Hz) Control panel reference is given in Hz. 2 = REF2 (%) Control panel reference is given as a percentage (%).
1102	EXT1/EXT2 SEL Sets the input used for selecting the external control location, or fixes it to EXT1 or EXT2. The external control location of both Start/Stop/Direction commands and reference is determined by this parameter. 1...5 = DI...DI5 External control location 1 or 2 is selected according to the state of the selected digital input (DI1 ... DI5), where deactivated = EXT1 and activated = EXT2. 6 = EXT1 External control location 1 (EXT1) is selected. The control signal sources for EXT1 are defined with parameter 1001 (Start/Stop/Direction commands) and parameter 1103 (reference). 7 = EXT2 External control location 2 (EXT2) is selected. The control signal sources for EXT2 are defined with parameter 1002 (Start/Stop/Direction commands) and parameter 1106 (reference). 8 = COMM External control location 1 or 2 is chosen through serial communication.

1103

EXT REF1 SELECT

This parameter selects the signal source of external reference 1.

0 = KEYPAD

Reference is given from the control panel.

1 = AI 1

Reference is given through analogue input 1.

2 = AI 2

Reference is given through analogue input 2.

3 = AI1/JOYST; 4 = AI2/JOYST

Reference is given through analogue input 1 (or 2 accordingly) configured for a joystick. The minimum input signal runs the drive at maximum reference in the reverse direction. The maximum input signal runs the drive at maximum reference in the forward direction (See Figure 5). See also parameter 1003 DIRECTION.

Caution: Minimum reference for joystick should be 0.3 V (0.6 mA) or higher. If a 0... 10 V signal is used, the ACS 160 will operate at maximum reference in the reverse direction if the control signal is lost. Set parameter 3022 AI1 FAULT LIMIT to a value 3% or higher, and parameter 3023 AI2 FAULT LIMIT to 1 (FAULT), and the ACS 160 will stop in case the control signal is lost.

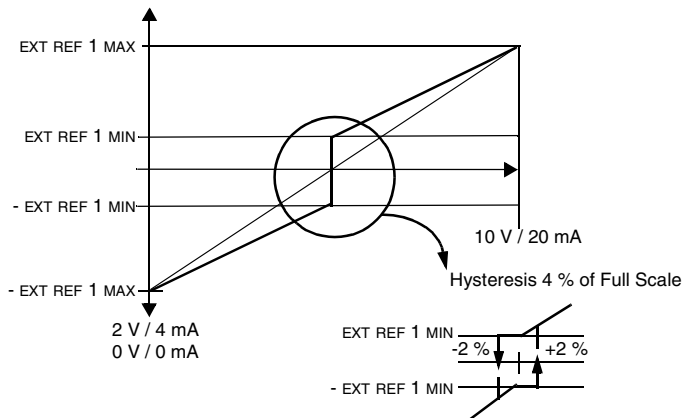

Figure 5 Joystick control. Maximum for external reference 1 is set with Parameter 1105 and minimum with Parameter 1104.

5 = DI3U,4D(R)

Speed reference is given through digital inputs as motor potentiometer control. Digital input DI3 increases the speed (the U stands for "up"), and digital input DI4 decreases the speed (the D stands for "down"). (R) indicates that the reference will be reset to zero when a Stop command is given. The rate of change of the reference signal is controlled by parameter 2204 ACCELER TIME 2.

6 = DI3U,4D

Same as above, except that the speed reference is not reset to zero on a Stop command. When the ACS 160 is started, the motor will ramp up at the selected acceleration rate to the stored reference.

7 = DI4U,5D

Same as above, except that the digital inputs in use are DI4 and DI5.

8 = COMM

The reference is given through serial communication.

9 = COMM + AI1

10 = COMM * AI1

The reference is given through serial communication. The analogue input 1 signal is combined to the fieldbus reference (sum or multiplication).

11 = DI3U,4D(R,NC); 12 = DI3U,4D(NC); 13 = DI4U,5D(NC)

Selections 11,12 and 13 are the same as selections 5,6,7 respectively, with the exception that the reference value is not copied when:

- moving from EXT1 to EXT 2, or
- moving from EXT2 to EXT1, or
- moving from local to remote.

1104	<p>EXT REF1 MIN Sets the minimum frequency reference for external reference 1 in Hz. When analogue input signal is at minimum, external reference 1 equals to EXT REF1 MIN. See Figure 6.</p>
1105	<p>EXT REF1 MAX Sets the maximum frequency reference for external reference 1 in Hz. When analogue input signal is at maximum, external reference 1 equals to EXT REF1 MAX. See Figure 6.</p>
1106	<p>EXT REF2 SELECT This parameter selects the signal source for external reference 2. The alternatives are the same as with external reference 1, see 1103 EXT REF1 SELECT.</p>
1107	<p>EXT REF2 MIN Sets the minimum reference in %. When analogue input signal is at minimum, external reference 2 equals to EXT REF2 MIN. See Figure 6.</p> <ul style="list-style-type: none"> • If the PID Control macro is selected, this parameter sets the minimum process reference. • If any other macro than PID is selected, this parameter sets the minimum frequency reference. This value is given as a percentage of the maximum frequency.
1108	<p>EXT REF2 MAX Sets the maximum reference in %. When analogue input signal is at maximum, external reference 2 equals to EXT REF2 MAX. See Figure 6.</p> <ul style="list-style-type: none"> • If the PID Control macro is selected, this parameter sets the maximum process reference. • If any other macro than PID Control is selected, this parameter sets the maximum frequency reference. This value is given as percentage of maximum frequency.
1115	<p>REF STEP SEL Frequency reference modification selection.</p> <p>0 = NOT SEL Reference modification is not used.</p> <p>1 = DI3U4D Reference correction up is given to frequency reference, when digital input DI3 is activated and reference correction down is given, when digital input DI4 is activated.</p> <p>2 = DI4U5D Same as above except that digital inputs in use are DI4 and DI5.</p>
1117	<p>REF STEP MODE</p> <p>0 = FREQ STEP Fixed frequency step is added to or subtracted from basic frequency reference. Frequency steps in Hz are defined with parameters 1118 REF STEP UP and 1119 REF STEP DOWN.</p> <p>1 = PERCENTAGE STEP In this case frequency step is given as percentage of basic frequency reference. Parameters 1118 REF STEP UP and 1119 REF STEP DOWN are defined as percentage values.</p>
1118	<p>REF STEP UP Frequency reference step up. Given as Hz or percentage depending on the value of parameter 1117 REF STEP MODE.</p>
1119	<p>REF STEP DOWN Frequency reference step down. Given as Hz or percentage depending on the value of parameter 1117 REF STEP MODE.</p>
1120	<p>STEP DLY ON Switch on delay for reference step.</p>
1121	<p>STEP DLY OFF Switch off delay for reference step</p>

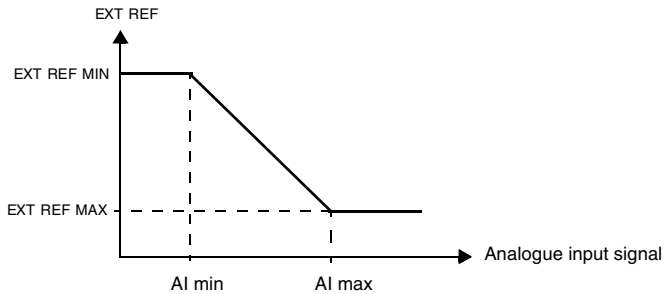
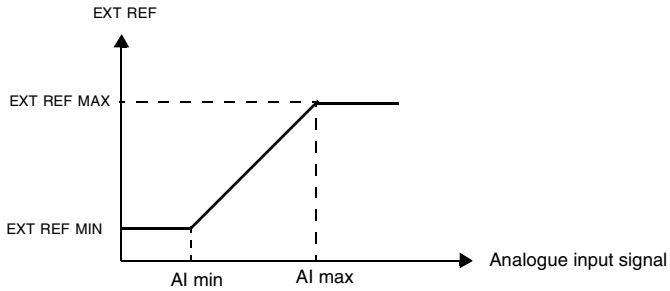

Figure 6 Setting EXT REF MINIMUM and EXT REF MAXIMUM. The range of the analogue input signal is set by parameters 1301 and 1302 or parameters 1304 and 1305, depending on the analogue input used.

Group 12: Constant Speeds

The ACS 160 has 7 programmable constant speeds, ranging from 0 to 250 Hz. Negative speed values cannot be given for constant speeds.

Constant speed selections are ignored if the process PID reference is followed, the drive is in local control mode.

Note! Parameter 1208 CONST SPEED 7 acts also as a so-called fault speed which may be activated if the control signal is lost. Refer to parameter 3001 AI<MIN FUNCTION and parameter 3002 PANEL LOSS.

Code	Description																																																			
1201	<p>CONST SPEED SEL This parameter defines which digital inputs are used to select Constant Speeds.</p> <p>0 = NOT SEL Constant speed function disabled.</p> <p>1...5 = DI1...DI5 Constant Speed 1 is selected with digital inputs DI1-DI5. Digital input activated = Constant Speed 1 activated.</p> <p>6 = DI1,2 Three Constant Speeds (1 ... 3) are selected with two digital inputs. Constant Speed selection with digital inputs DI1,2.</p> <p>Table 1 Constant Speed selection with digital inputs DI1,2.</p> <table border="1"> <thead> <tr> <th>DI 1</th> <th>DI 2</th> <th>Function</th> </tr> </thead> <tbody> <tr> <td>0</td> <td>0</td> <td>No constant speed</td> </tr> <tr> <td>1</td> <td>0</td> <td>Constant speed 1 (1202)</td> </tr> <tr> <td>0</td> <td>1</td> <td>Constant speed 2 (1203)</td> </tr> <tr> <td>1</td> <td>1</td> <td>Constant speed 3 (1204)</td> </tr> </tbody> </table> <p>0 = DI deactivated, 1 = DI activated</p> <p>7 = DI3,4 Three Constant Speeds (1 ... 3) are selected with two digital inputs as in DI1,2.</p> <p>8 = DI4,5 Three Constant Speeds (1 ... 3) are selected with two digital inputs as in DI1,2.</p> <p>9 = DI1,2,3 Seven Constant Speeds (1 ... 7) are selected with three digital inputs.</p> <p>Table 2 Constant Speed selection with digital inputs DI1,2,3.</p> <table border="1"> <thead> <tr> <th>DI 1</th> <th>DI 2</th> <th>DI 3</th> <th>Function</th> </tr> </thead> <tbody> <tr> <td>0</td> <td>0</td> <td>0</td> <td>No constant speed</td> </tr> <tr> <td>1</td> <td>0</td> <td>0</td> <td>Constant speed 1 (1202)</td> </tr> <tr> <td>0</td> <td>1</td> <td>0</td> <td>Constant speed 2 (1203)</td> </tr> <tr> <td>1</td> <td>1</td> <td>0</td> <td>Constant speed 3 (1204)</td> </tr> <tr> <td>0</td> <td>0</td> <td>1</td> <td>Constant speed 4 (1205)</td> </tr> <tr> <td>1</td> <td>0</td> <td>1</td> <td>Constant speed 5 (1206)</td> </tr> <tr> <td>0</td> <td>1</td> <td>1</td> <td>Constant speed 6 (1207)</td> </tr> <tr> <td>1</td> <td>1</td> <td>1</td> <td>Constant speed 7 (1208)</td> </tr> </tbody> </table> <p>0 = DI deactivated, 1 = DI activated</p> <p>10 = DI3,4,5 Seven Constant Speeds (1 ... 7) are selected with three digital inputs as in DI1,2,3.</p>	DI 1	DI 2	Function	0	0	No constant speed	1	0	Constant speed 1 (1202)	0	1	Constant speed 2 (1203)	1	1	Constant speed 3 (1204)	DI 1	DI 2	DI 3	Function	0	0	0	No constant speed	1	0	0	Constant speed 1 (1202)	0	1	0	Constant speed 2 (1203)	1	1	0	Constant speed 3 (1204)	0	0	1	Constant speed 4 (1205)	1	0	1	Constant speed 5 (1206)	0	1	1	Constant speed 6 (1207)	1	1	1	Constant speed 7 (1208)
DI 1	DI 2	Function																																																		
0	0	No constant speed																																																		
1	0	Constant speed 1 (1202)																																																		
0	1	Constant speed 2 (1203)																																																		
1	1	Constant speed 3 (1204)																																																		
DI 1	DI 2	DI 3	Function																																																	
0	0	0	No constant speed																																																	
1	0	0	Constant speed 1 (1202)																																																	
0	1	0	Constant speed 2 (1203)																																																	
1	1	0	Constant speed 3 (1204)																																																	
0	0	1	Constant speed 4 (1205)																																																	
1	0	1	Constant speed 5 (1206)																																																	
0	1	1	Constant speed 6 (1207)																																																	
1	1	1	Constant speed 7 (1208)																																																	
1202 -1208	<p>CONST SPEED 1... CONST SPEED 7 Constant speeds 1-7.</p>																																																			

Group 13: Analogue Inputs

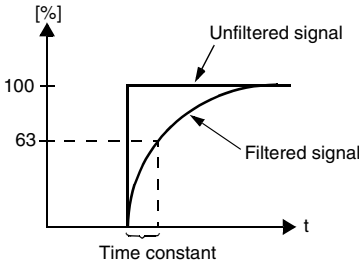
Code	Description
1301	<p>MINIMUM AI1 Relative minimum value of AI1 (%). Value corresponds to minimum reference set by parameter 1104 EXT REF1 MIN or 1107 EXT REF2 MIN. Minimum AI cannot be greater than maximum AI. See Figure 6.</p>
1302	<p>MAXIMUM AI1 Maximum value of AI1 (%). Value corresponds to maximum reference set by parameter 1105 EXT REF1 MAX or 1108 EXT REF2 MAX. See Figure 6.</p>
1303	<p>FILTER AI1 Filter time constant for analogue input AI1. As the analogue input value changes, 63 % of the change takes place within the time specified by this parameter.</p> <p>Note! Even if you select 0 s for the filter time constant, the signal is still filtered with a time constant of 25 ms due to the signal interface hardware. This cannot be changed by any parameters.</p>  <p>Figure 7 Filter time constant for analogue input AI1.</p>
1304	<p>MINIMUM AI2 Minimum value of AI2 (%). Value corresponds to minimum reference set by parameter 1104 EXT REF1 MIN or 1107 EXT REF2 MIN. Minimum AI cannot be greater than maximum AI.</p>
1305	<p>MAXIMUM AI2 Maximum value of AI2 (%). Value corresponds to maximum reference set by parameter 1105 EXT REF1 MAX or 1108 EXT REF2 MAX.</p>
1306	<p>FILTER AI2 Filter time constant for AI2. Refer to parameter 1303 FILTER AI1.</p>

Example. To set the minimum allowed analogue input value to 4 mA, value for parameter 1301 MINIMUM AI1 (1304 MINIMUM AI2) is calculated as follows:

$$\text{Value (\%)} = \text{Desired minimum value} / \text{Full range of the analogue input} * 100\%$$

$$= 4 \text{ mA} / 20 \text{ mA} * 100\%$$

$$= 20\%.$$

Note! In addition to this parameter setting, the analog input must be configured for 0-20 mA current signal. Refer to Reference Section L.

Group 14: Relay Outputs

Code	Description
1401	<p>RELAY OUTPUT 1 Relay output 1 content. Selects which information is indicated with relay output 1.</p> <p>0 = NOT SEL Relay is not used and is de-energised.</p> <p>1 = READY The ACS 160 is ready to function. The relay is energised unless no run enable signal is present or a fault exists and supply voltage is within range.</p> <p>2 = RUN Relay energised when the ACS 160 is running.</p> <p>3 = FAULT (-1) Relay energised when power is applied, and de-energised upon a fault trip.</p> <p>4 = FAULT Relay energised when a fault is active.</p> <p>5 = ALARM Relay energised when an alarm is active. To see which alarms cause the relay to energise, refer to Diagnostics section.</p> <p>6 = REVERSED Relay energised when motor rotates in reverse direction.</p> <p>7 = SUPRV1 OVER Relay energised when first supervised parameter (3201) exceeds the limit (3203). See Group 32: Supervision.</p> <p>8 = SUPRV1 UNDER Relay energised when first supervised parameter (3201) drops below the limit (3202). See Group 32: Supervision.</p> <p>9 = SUPRV2 OVER Relay energised when second supervised parameter (3204) exceeds the limit (3206). See Group 32: Supervision.</p> <p>10 = SUPRV2 UNDER Relay energised when second supervised parameter (3204) drops below the limit (3205). See Group 32: Supervision.</p> <p>11 = AT SET POINT Relay energised when output frequency is equal to reference frequency.</p> <p>12 = FAULT (RST) Relay energised when the ACS 160 is in a fault condition and will reset after the programmed autoreset delay (refer to parameter 3103 DELAY TIME).</p> <p>13 = FLT/ALARM Relay is energised when fault or alarm occurs. To see which alarms and faults cause the relay to energise, refer to section on Diagnostics.</p> <p>14 = EXT CONTROL Relay is energised if external control is selected.</p> <p>15 = REF 2 SEL Relay is energised if EXT2 is selected.</p> <p>16 = CONST FREQ Relay is energised when a constant speed is selected.</p> <p>17 = REF LOSS Relay is energised when reference or active control place is lost.</p> <p>18 = OVERCURRENT Relay is energised when overcurrent alarm or fault appears.</p> <p>19 = OVERVOLTAGE Relay is energised when overvoltage alarm or fault appears.</p> <p>20 = ACS160 TEMP Relay is energised when ACS 160 overtemperature alarm or fault exists.</p>

Code	Description
	<p>21 = ACS OVERLOAD Relay is energised when ACS 160 overload alarm or fault exists.</p> <p>22 = UNDERVOLTAGE Relay is energised when undervoltage alarm or fault exists.</p> <p>23 = AI1 LOSS Relay is energised when AI1 signal is lost.</p> <p>24 = AI2 LOSS Relays energised when AI2 signal is lost.</p> <p>25 = MOT OVR TEMP Relay is energised when motor overtemperature alarm or fault exists.</p> <p>26 = STALL Relay is energised when stall alarm or fault exists.</p> <p>27 = UNDERLOAD Relay is energised when underload alarm or fault exists.</p> <p>28 = PID SLEEP Relay is energised when PID sleep function is active.</p> <p>29 - 30 = (reserved)</p> <p>31 = STARTED Relay is energised when drive receives start command (even if Run Enable signal is not present). Relay is de-energised when stop command is received or fault occurs.</p> <p>32 = MEC BR CNTRL Relay is used to control electromechanical brake. Refer to Group 54: Braking for more information.</p> <p>33 = BCH FAULT Relay is de-energised if brake resistor is overloaded. Refer to brake resistor instructions for more information.</p> <p>34 = AT TARGET Target positioning is reached. Use only when positioning macro is used.</p>
1402	<p>RELAY OUTPUT 2 Relay output 2 content. Refer to parameter 1401 RELAY OUTPUT 1.</p>
1403	<p>RO 1 ON DELAY Switch-on delay for relay 1.</p>
1404	<p>RO 1 OFF DELAY Switch-off delay for relay 1</p>
1405	<p>RO 2 ON DELAY Switch-on delay for relay 2.</p>
1406	<p>RO 2 OFF DELAY Switch-off delay for relay 2.</p>

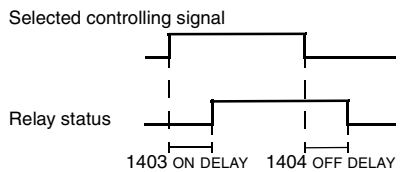

Figure 8

Group 15: Analogue Output

Analogue output is used to output the value of any parameter of the Operating Data group (Group 1) as a current signal. Output current minimum and maximum values are configurable, as are the allowed minimum and maximum values for the observed parameter.

If analogue output content maximum value (parameter 1503) is set to less than minimum value (parameter 1502), output current is inversely proportional to the value of the observed parameter.

Code	Description
1501	AO CONTENT Content for analogue output. Number of any parameter of the Operating Data group (Group 01).
1502	AO CONTENT MIN Analogue output content minimum. Display depends on parameter 1501.
1503	AO CONTENT MAX Analogue output content maximum. Display depends on parameter 1501.
1504	MINIMUM AO Minimum output current.
1505	MAXIMUM AO Maximum output current.
1506	AO FILTER Filter time constant for AO.

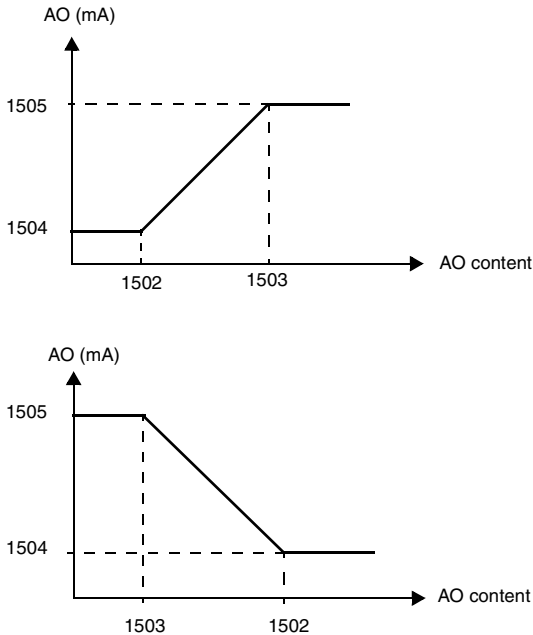

Figure 9 Analogue output scaling.

Group 16: System Controls

Code	Description
1601	<p>RUN ENABLE Selects the source of the run enable signal.</p> <p>0 = NOT SEL The ACS 160 is ready to start without an external run enable signal.</p> <p>1...5 = DI1 ... DI5 To activate the run enable signal, the selected digital input must be activated. If the voltage drops and deactivates the selected digital input, the ACS 160 will coast to stop and not start until the run enable signal resumes.</p> <p>6 = COMM The run enable signal is given through serial communication (Command Word bit #3).</p>
1602	<p>PARAMETER LOCK Parameter lock for control panel.</p> <p>0 = LOCKED Parameter modification disabled.</p> <p>1 = OPEN Panel operations are allowed and parameter modification is enabled.</p> <p>Note! This parameter is not affected by macro selection.</p>
1604	<p>FAULT RESET SEL Fault reset source.</p> <p>Note! Fault reset is always possible with control panel.</p> <p>Note! Option 6 (START/STOP) should not be selected when start, stop and direction commands are given through serial communication.</p> <p>0 = KEYPAD Fault reset is executed from the control panel keypad.</p> <p>1...5 = DI1 ... DI5 Fault reset is executed from a digital input. Reset is activated by deactivating the input.</p> <p>6 = START/STOP Fault reset is activated by Stop command.</p> <p>7 = COMM Fault reset is executed through serial communication.</p>
1605	<p>LOCAL LOCK Local lock. When LOCAL LOCK is active (1=LOCKED), the drive cannot be changed from remote mode to local mode.</p> <p>0 = OPEN Control location can be changed from control panel.</p> <p>1 = LOCKED Panel cannot change to local mode.</p> <p>Note! Option 1 LOCKED can be selected only in remote mode.</p>
1608	<p>DISPLAY ALARMS Controls the visibility of some of the alarms, see Diagnostics.</p> <p>0 = NO Some of the alarms are suppressed.</p> <p>1 = YES All of the alarms are enabled.</p>

Group 20: Limits

Code	Description
2003	<p>MAX CURRENT Maximum output current. The maximum output current that the ACS 160 will supply to the motor.</p>
2005	<p>OVERVOLT CTRL DC overvoltage controller enable.</p> <p>Fast braking of a high inertia load causes the DC bus voltage to rise to the overvoltage control limit. To prevent the DC voltage from exceeding the limit, the overvoltage controller automatically decreases the braking torque by increasing output frequency.</p> <p>Caution! If a braking resistor is connected to the ACS 160, this parameter value must be set to 0 to enable proper operation of the chopper. Do not set this parameter to 0 if braking resistor is not connected</p> <p>0 = DISABLE 1 = ENABLE</p>
2006	<p>UNDERVOLT CTRL DC undervoltage controller enable.</p> <p>If the DC bus voltage drops due to loss of input power, the undervoltage controller will decrease the motor speed in order to keep the DC bus voltage above the lower limit. By decreasing the output frequency, the inertia of the load will cause regeneration back into the ACS 160, thus keeping the DC bus charged, and preventing an undervoltage trip. This will increase power loss ride-through on systems with a high inertia, such as a centrifuge or a fan.</p> <p>0 = DISABLE 1 = ENABLE (TIME) Enable with 500 ms time limit for operation. 2 = ENABLE Enable without time limit for operation.</p>
2007	<p>MINIMUM FREQ Operating range minimum output frequency.</p> <p>Note! Keep MINIMUM FREQ ≤ MAXIMUM FREQ.</p>
2008	<p>MAXIMUM FREQ Operating range maximum output frequency.</p>

Group 21: Start/Stop

ACS 160 supports several start and stop modes, including flying start and torque boosting at start. DC current can be injected either before the start command (premagnetising) or automatically right after the start command (starting with DC hold).

DC hold can be used when stopping the drive with ramp. If drive is stopping by coasting, DC brake can be used.

Note! Too long a DC injection time or premagnetising time causes the motor to heat up.

Code	Description
2101	<p>START FUNCTION Conditions during motor acceleration.</p> <p>1 = RAMP Ramp acceleration as set.</p> <p>2 = FLYING Flying start. Use this setting if the motor is already rotating and the drive will start smoothly at the current frequency. The drive will automatically search the correct output frequency.</p> <p>3 = TORQUE BOOST Automatic torque boost might be necessary in drives with high starting torque. Torque boost is only applied at start. Boosting is stopped when output frequency exceeds 20 Hz or when output frequency is equal to reference. See also parameter 2103 TORQ BOOST CURR.</p> <p>4 = FLY + BOOST Activates both the flying start and torque boost.</p> <p>Note! If torque boost is used the switching frequency is always 4 kHz. In this case parameter 2605 LOW NOISE is ignored.</p>
2102	<p>STOP FUNCTION Conditions during motor deceleration.</p> <p>1 = COAST Motor coasts to stop.</p> <p>2 = RAMP Ramp deceleration as defined by the active deceleration time 2203 DECELER TIME 1 or 2205 DECELER TIME 2.</p>
2103	<p>TORQ BOOST CURR Maximum supplied current during torque boost. See also parameter 2101 START FUNCTION.</p>
2104	<p>STOP DC INJ TIME DC injection time after modulation has stopped. If 2102 STOP FUNCTION is 1 (COAST), ACS 160 uses DC braking. If 2102 STOP FUNCTION is 2 (RAMP), ACS 160 uses DC hold after ramp.</p>
2105	<p>PREMAGN SEL Options 1- 5 select source for premagnetising command. Option 6 selects start with DC hold.</p> <p>0 = NOT SEL Premagnetising not used.</p> <p>1..5 = DI1...DI5 Premagnetising command is received through a digital input.</p> <p>6 = CONST Constant premagnetising time after start command. Time is defined by parameter 2106 PREMAGN MAX TIME.</p>
2106	<p>PREMAGN MAX TIME Maximum premagnetising time.</p>

Code	Description
2107	<p>START INHIBIT</p> <p>Start inhibit control. Start inhibit means that a pending start command is ignored when:</p> <ul style="list-style-type: none"> • fault is reset, or • Run Enable activates while start command is active, or • mode change from local to remote takes place, or • mode change from remote to local takes place, or • when switching from EXT1 to EXT2 takes place, or • when switching from EXT2 to EXT1 takes place <p>0 = OFF Start inhibit control disabled. Drive will start after fault is reset, Run Enable is activated or mode is changed while there is a pending start command.</p> <p>1 = ON Start inhibit control enabled. Drive will not start after fault is reset, Run Enable is activated or mode is changed. In order to start the drive again, give start command anew.</p>

Group 22: Accel/Decel

Two acceleration/deceleration ramp pairs can be used. If both ramp pairs are used, selection can be made between these in run time through a digital input. The S curve of the ramps is adjustable.

Code	Description
2201	<p>ACC/DEC 1/2 SEL Selects the source for the ramp pair selection signal.</p> <p>0 = NOT SEL The first ramp pair is used (ACCELER TIME 1/DECELER TIME 1).</p> <p>1...5 = DI1...DI5 Ramp pair selection is done through a digital input (DI1 to DI5). Digital input deactivated = Ramp pair 1 (ACCELER TIME 1/DECELER TIME 1) is used. Digital input activated = Ramp pair 2 (ACCELER TIME 2/DECELER TIME 2) is used.</p>
2202	<p>ACCELER TIME 1 Ramp 1: time from zero to maximum frequency (0 - MAXIMUM FREQ).</p>
2203	<p>DECELER TIME 1 Ramp 1: time from maximum frequency to zero (MAXIMUM FREQ - 0).</p>
2204	<p>ACCELER TIME 2 Ramp 2: time from zero to maximum frequency (0 - MAXIMUM FREQ).</p>
2205	<p>DECELER TIME 2 Ramp 2: time from maximum frequency to zero (MAXIMUM FREQ - 0).</p>
2206	<p>RAMP SHAPE Acceleration/deceleration ramp shape selection</p> <p>0 = LINEAR 1 = FAST S CURVE 2 = MEDIUM S CRV 3 = SLOW S CURVE</p>

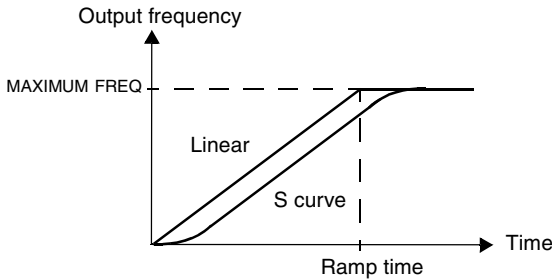

Figure 10 Definition of acceleration/deceleration ramp time.

Group 25: Critical Freq

In some mechanical systems, certain speed ranges can cause resonance problems. With this parameter group, it is possible to set up to two different speed ranges that the ACS 160 will skip over.

Code	Description
2501	CRIT FREQ SEL Critical frequencies activation. 0 = OFF 1 = ON
2502	CRIT FREQ 1 LO Critical frequency 1 start. Note! If LOW > HI, no critical frequency lock-out will happen.
2503	CRIT FREQ 1 HI Critical frequency 1 end.
2504	CRIT FREQ 2 LO Critical frequency 2 start.
2505	CRIT FREQ 2 HI Critical frequency 2 end. Note! If LOW > HI, no critical frequency lock-out will happen.

Example: A fan system vibrates badly from 18 Hz to 23 Hz and from 46 Hz to 52 Hz. Set the parameters as follows:

CRIT FREQ 1 LO = 18 Hz and CRIT FREQ 1 HI = 23 Hz

CRIT FREQ 2 LO = 46 Hz and CRIT FREQ 2 HI = 52 Hz

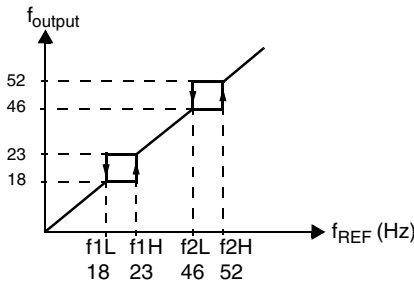

Figure 11 Example of critical frequencies setting in a fan system with bad vibrations at frequency ranges 18 Hz to 23 Hz and 46 Hz to 52 Hz.

Group 26: Motor Control

Code	Description																		
2603	<p>IR COMPENSATION IR compensation voltage at 0 Hz.</p> <p>Note! IR compensation should be kept as low as possible to prevent overheating. Refer to Table 3.</p> <table border="1" data-bbox="476 183 909 331"> <thead> <tr> <th colspan="6">400 V Units</th> </tr> <tr> <th>P_N / kW</th> <td>0,55</td> <td>0,75</td> <td>1,1</td> <td>1,5</td> <td>2,2</td> </tr> <tr> <th>IR comp / V</th> <td>33</td> <td>30</td> <td>27</td> <td>25</td> <td>23</td> </tr> </thead> </table>	400 V Units						P_N / kW	0,55	0,75	1,1	1,5	2,2	IR comp / V	33	30	27	25	23
400 V Units																			
P_N / kW	0,55	0,75	1,1	1,5	2,2														
IR comp / V	33	30	27	25	23														
2604	<p>IR COMP RANGE IR compensation range. Defines frequency after which IR compensation is 0 V.</p>																		
2605	<p>LOW NOISE Motor acoustical noise option.</p> <p>0 = OFF Standard (switching frequency 4 kHz).</p> <p>1 = ON(1) Low noise (switching frequency 8 kHz).</p> <p>Note! When the low noise setting is used, the maximum loadability must be derated, see reference section N.</p>																		
2606	<p>U/f RATIO U/f ratio below field weakening point.</p> <p>1 = LINEAR 2 = SQUARE</p> <p>Linear is preferred for constant torque applications, Square for centrifugal pump and fan applications. (Square is more silent for most operating frequencies.)</p>																		
2607	<p>SLIP COMP RATIO A squirrel-cage motor will slip under load. The slip can be compensated by increasing the frequency as the motor torque increases. This parameter defines the gain for the slip. 100 % means full slip compensation; 0 % means no slip compensation.</p>																		

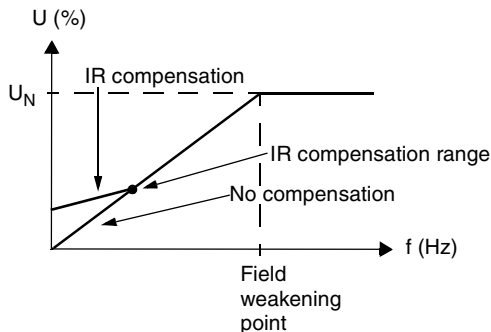

Figure 12 Operation of IR compensation

Group 30: Fault Functions

ACS 160 can be configured to respond as desired to certain abnormal external conditions: analogue input fault, external fault signal and panel loss.

In these cases, the drive can either continue operation at current speed or at a set constant speed while showing an alarm, ignore the condition, or trip on a fault and stop.

Motor thermal protection parameters 3004 - 3008 provide a means of adjusting the motor load curve. For example, limiting the load near zero speed might be necessary if the motor does not have a cooling fan.

Stall protection (parameters 3009 - 3012) includes parameters for stall frequency, stall time and current.

Code	Description
3001	<p>AI<MIN FUNCTION Operation in case of AI signal drops below fault limit 3022 AI1 FLT LIMIT or 3023 AI2 FLT LIMIT.</p> <p>0 = NOT SEL No operation.</p> <p>1 = FAULT A fault indication is displayed and the ACS 160 coasts to stop.</p> <p>2 = CONST SP 7 A warning indication is displayed and the speed is set according to parameter 1208 CONST SPEED7.</p> <p>3 = LAST SPEED A warning indication is displayed and the speed is set to the level the ACS 160 was last operating at. This value is determined by the average speed over the last 10 seconds.</p> <p>Caution: If you select CONST SPEED 7 or LAST SPEED, make sure that it is safe to continue operation in case analogue input signal is lost.</p>
3002	<p>PANEL LOSS Operation in case of control panel loss fault.</p> <p>1 = FAULT A fault indication is displayed and the ACS 160 coasts to stop.</p> <p>2 = CONST SP 7 A warning indication is displayed and the speed is set according to parameter 1208 CONST SPEED7.</p> <p>3 = LAST SPEED A warning indication is displayed and the speed is set to the level the ACS 160 was last operating at. This value is determined by the average speed over the last 10 seconds.</p> <p>Caution: If you select CONST SPEED 7 or LAST SPEED, make sure that it is safe to continue operation in case panel is lost.</p>
3003	<p>EXTERNAL FAULT External fault input selection.</p> <p>0 = NOT SEL External fault signal is not used.</p> <p>1...5 = DI1...DI5 This selection defines the digital input used for an external fault signal. If an external fault occurs, i.e. digital input is deactivated, the ACS 160 is stopped and the motor coasts to stop and fault indication is displayed.</p>

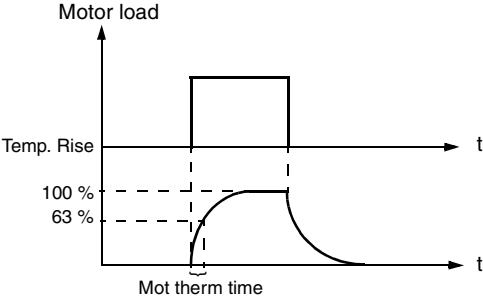
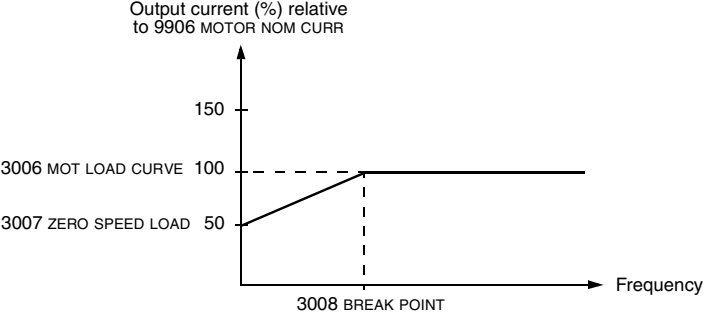
Code	Description
3004	<p>MOT THERM PROT Motor overtemperature function. This parameter defines the operation of the motor thermal protection function which protects the motor from overheating.</p> <p>0 = NOT SEL 1 = FAULT Displays a warning indication at the warning level (97.5 % of the nominal value). Displays a fault indication when the motor temperature reaches the 100 % level. The ACS 160 coasts to stop. 2 = WARNING A warning indication is displayed when the motor temperature reaches the warning level (95 % of the nominal value).</p>
3005	<p>MOT THERM TIME Time for 63 % temperature rise. This is the time within which the motor temperature reaches 63 % of the final temperature rise. Figure 13 shows motor thermal time definition.</p> <p>If thermal protection according to UL requirements for NEMA class motors is desired, use this rule of thumb - MOTOR THERM TIME equals 35 times t₆ (t₆ in seconds is the time that the motor can safely operate at six times its rated current, given by the motor manufacturer). The thermal time for a Class 10 trip curve is 350 s, for a Class 20 trip curve 700 s and for a Class 30 trip curve 1050 s.</p>  <p>Figure 13 Motor thermal time.</p>
3006	<p>MOT LOAD CURVE Motor current maximum limit. MOTOR LOAD CURVE sets the maximum allowable operating load of the motor. When set to 100 %, the maximum allowable load is equal to the value of Start-up Data parameter 9906 MOTOR NOM CURRENT. The load curve level should be adjusted if the ambient temperature differs from the nominal value.</p>  <p>Figure 14 Motor load curve.</p>

Code	Description
3007	ZERO SPEED LOAD This parameter defines the maximum allowable current at zero speed relative to 9906 MOTOR NOM CURR. Refer to Figure 14.
3008	BREAK POINT Break point of motor load curve. Refer to Figure 14 for an example of a motor load curve. See Figure 16.
3009	STALL FUNCTION This parameter defines the operation of the stall protection. The protection is activated if the output current becomes too high compared to output frequency, refer to Figure 15. 0 = NOT SEL Stall protection is not used. 1 = FAULT When the protection is activated the ACS 160 coasts to stop. Fault indication is displayed. 2 = WARNING A warning indication is displayed. The indication disappears in half the time set by parameter 3012 STALL TIME. <div data-bbox="273 549 913 847" data-label="Figure"> </div> Figure 15 Motor stall protection.
3010	STALL CURRENT Current limit for stall protection. Refer to Figure 15.
3011	STALL FREQ HI This parameter sets the frequency value for the stall function. Refer to Figure 15.
3012	STALL TIME This parameter sets the time value for the stall function.
3013	UNDERLOAD FUNCTION Removal of motor load may indicate a process malfunction. The protection is activated if: <ul style="list-style-type: none"> • The motor torque drops below the load curve selected by parameter 3015 UNDERLOAD CURVE. • This condition has lasted longer than the time set by parameter 3014 UNDERLOAD TIME. • Output frequency is higher than 10 % of the nominal frequency of the motor and higher than 5 Hz. 0 = NOT SEL Underload protection is not used. 1 = FAULT When the protection is activated the ACS 160 coasts to stop. Fault indication is displayed. 2 = WARNING A warning indication is displayed.
3014	UNDERLOAD TIME Time limit for underload protection.

Code	Description
3015	UNDERLOAD CURVE This parameter provides five selectable curves shown in Figure 17. If the load drops below the set curve for longer than the time set by parameter 3014, the underload protection is activated. Curves 1...3 reach maximum at the motor rated frequency set by parameter 9907 MOTOR NOM FREQ.
3022	AI1 FLT LIMIT Fault level for analogue input 1 supervision. See parameter 3001 AI<MIN FUNCTION.
3023	AI2 FLT LIMIT Fault level for analogue input 2 supervision. See parameter 3001 AI<MIN FUNCTION.
3024	MOT THERM MODE 2 = USER MODE In this mode the user can define the operation of thermal protection by setting parameters 3005 MOTOR THERM TIME, 3006 MOT LOAD CURVE, 3007 ZERO SPEED LOAD and 3008 BREAK POINT. 3 = THERMISTOR Motor thermal protection is activated with an I/O signal based on motor thermistor. This mode requires a motor thermistor or break contact of a thermistor relay connected to terminal X4. See Reference Section O. When overtemperature is detected, the drive stops if the parameter 3004 MOTOR THERM PROT is set to 1 (FAULT).

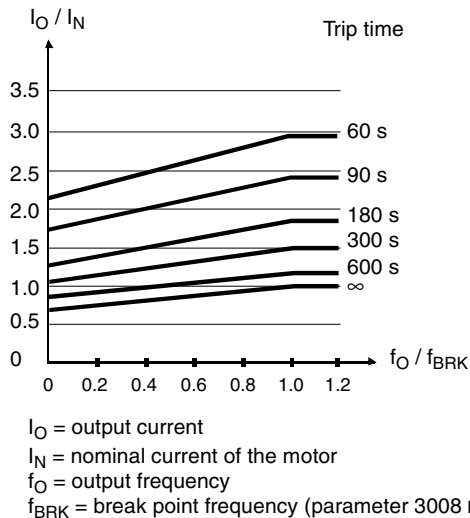

Figure 16 Thermal protection trip times when parameters 3005 MOT THERM TIME, 3006 MOT LOAD CURVE and 3007 ZERO SPEED LOAD have default values.

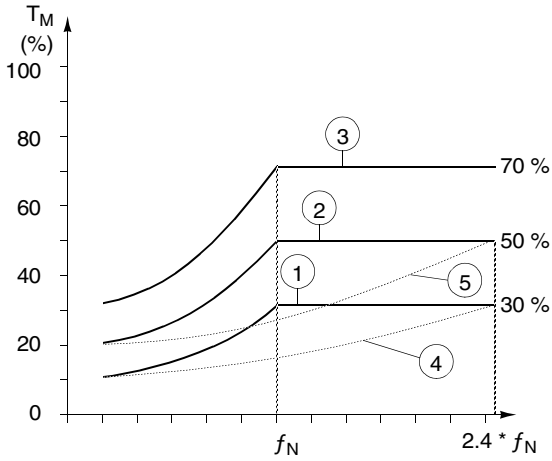

Figure 17 Underload curve types. T_M nominal torque of the motor, f_N nominal frequency of the motor.

Group 31: Automatic Reset

The automatic reset system can be used for resetting overcurrent, overvoltage, undervoltage and analogue input loss faults automatically. Number of allowed automatic reset operations within a certain time is selectable.

Warning! If parameter 3107 AR AI<MIN is enabled, the drive may restart even after a long stop when the analogue input signal is restored. Ensure that the use of this feature will not cause physical injury and/or damage equipment.

Code	Description
3101	NR OF TRIALS Sets the number of allowed autoresets within a certain time. The time is defined with parameter 3102 TRIAL TIME. The ACS 160 prevents additional autoresets and remains stopped until a successful reset is performed from the control panel or from a place selected by parameter 1604 FAULT RESET SEL.
3102	TRIAL TIME The time within which a limited number of fault autoresets is allowed. The allowed number of faults per this time period is given with parameter 3101 NR OF TRIALS.
3103	DELAY TIME This parameter sets the time that the ACS 160 will wait after a fault occurs before attempting to reset. If set to zero, the ACS 160 will reset immediately.
3104	AR OVERCURRENT 0 = DISABLE 1 = ENABLE If 1 is selected, the fault (motor overcurrent) is reset automatically after the delay set by parameter 3103, and the ACS 160 resumes normal operation.
3105	AR OVERVOLTAGE 0 = DISABLE 1 = ENABLE If 1 is selected, the fault (DC bus overvoltage) is reset automatically after the delay set by parameter 3103, and the ACS 160 resumes normal operation.
3106	AR UNDERVOLTAGE 0 = DISABLE 1 = ENABLE If 1 is selected, the fault (DC bus undervoltage) is reset automatically after the delay set by parameter 3103 DELAY TIME, and the ACS 160 resumes normal operation.
3107	AR AI<MIN 0 = DISABLE 1 = ENABLE If 1 is selected, the fault (analogue input signal under minimum level) is reset automatically after the delay set by parameter 3103 DELAY TIME.

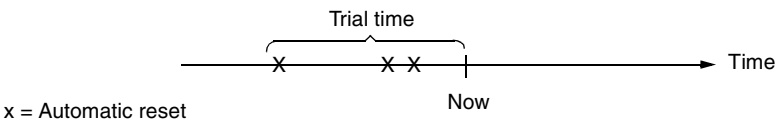
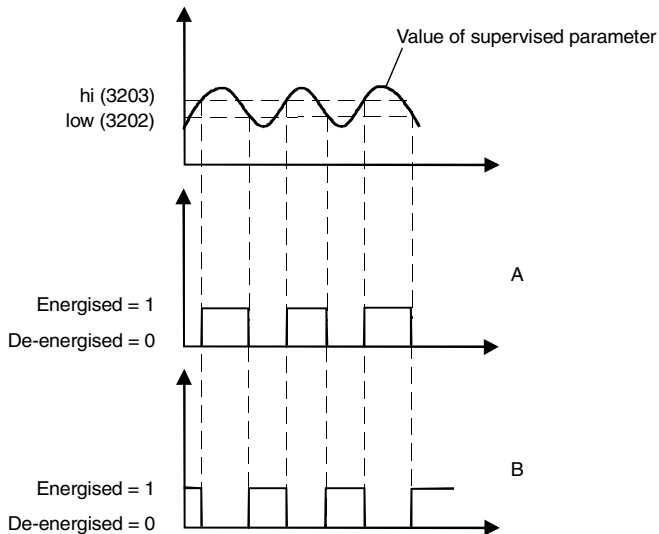

Figure 18 Operation of automatic reset function. In this example, if the fault occurs at the moment "Now", it is automatically reset if parameter 3101 NR OF TRIALS value is greater than or equal to 4.

Group 32: Supervision

Parameters of this group are used together with relay output parameters 1401 RELAY OUTPUT 1 and 1402 RELAY OUTPUT 2. Any two parameters of the Operating Data group (Group 1) can be supervised. Relays can be configured to be energised when the values of supervised parameters are either too low or too high.

Code	Description
3201	SUPERV 1 PARAM First supervised parameter number of the Operating Data group (Group 01).
3202	SUPERV 1 LIM LO First supervision limit low. Display of this parameter depends on selected supervised parameter (3201).
3203	SUPERV 1 LIM HI First supervision limit high. Display of this parameter depends on selected supervised parameter (3201).
3204	SUPERV 2 PARAM Second supervised parameter number of the Operating Data group (Group 01).
3205	SUPERV 2 LIM LO Second supervision limit low. Display of this parameter depends on selected supervised parameter (3204).
3206	SUPERV 2 LIM HI Second supervision limit high. Display of this parameter depends on selected supervised parameter (3204).



A = Parameter 1401 RELAY OUTPUT 1 (1402 RELAY OUTPUT 2) value is SUPRV1 OVER or SUPRV2 OVER

B = Parameter 1401 RELAY OUTPUT 1 (1402 RELAY OUTPUT 2) value is SUPRV1 UNDER or SUPRV2 UNDER

Note! Case $LOW \leq HIGH$ represents a normal hysteresis.

Case A: Is for monitoring when/if the supervised signal exceeds a given limit.

Case B: Is for monitoring when/if the supervised signal falls below a given limit.

Figure 19 Operating data supervision using relay outputs, when $LOW \leq HIGH$.

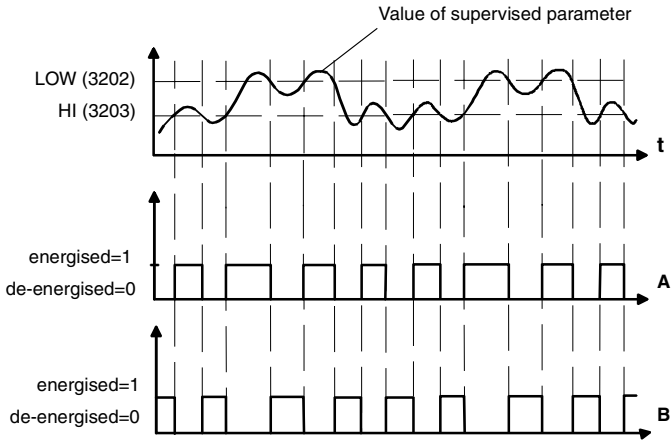

A = Parameter 1401 RELAY OUTPUT 1 (1402 RELAY OUTPUT 2) value is SUPRV1 OVER or SUPRV2 OVER.

B = Parameter 1401 RELAY OUTPUT 1 (1402 RELAY OUTPUT 2) value is SUPRV1 UNDER or SUPRV2 UNDER.

Note! Case LOW>HIGH represents a special hysteresis with two separate supervision limits. Depending on whether the supervised signal has gone below value HIGH (3203) or above value LOW (3202), determines which limit is being used. Initially HIGH is used, until the signal goes above value LOW. After this the limit used is LOW, until the signal goes back below value HIGH.

A = Initially the relay is de-energised.

B = Initially the relay is energised.

Figure 20 Operating data supervision using relay outputs, when LOW>HIGH.

Group 33: Information

Code	Description
3301	SW VERSION Software version.
3302	TEST DATE Displays the test date of the ACS 160 (yy.ww).

Group 34: Process Variables

Parameters of this group can be used to create custom process variables. Values of process variables can be seen in parameters 0134 PROCESS VAR 1 and 0135 PROCESS VAR 2. Value is calculated by taking given parameter from the operating data group (Group 1), and multiplying and dividing it with given coefficients. The number of displayed decimal digits is configurable.

See example below.

Code	Description										
3402	P VAR 1 SEL Selection of process variable 1. Number of any parameters of the group 1 OPERATING DATA (excluding parameters 0134 PROCESS VAR 1 and 0135 PROCESS VAR 2).										
3403	P VAR 1 MULTIP Process variable 1 multiplier.										
3404	P VAR 1 DIVISOR Process variable 1 divider.										
3405	<p>P VAR 1 SCALING Decimal point location of process variable 1, when displayed. Refer to Figure 21.</p> <table border="1" data-bbox="584 564 908 726"> <thead> <tr> <th>Value</th> <th>Display</th> </tr> </thead> <tbody> <tr> <td>0</td> <td>125</td> </tr> <tr> <td>1</td> <td>12.5</td> </tr> <tr> <td>2</td> <td>1.25</td> </tr> <tr> <td>3</td> <td>0.125</td> </tr> </tbody> </table> <p>Figure 21 Display with different decimal point locations when calculated value is 125.</p>	Value	Display	0	125	1	12.5	2	1.25	3	0.125
Value	Display										
0	125										
1	12.5										
2	1.25										
3	0.125										
3407	P VAR 2 SEL Selection of process variable 2. Number of any parameters of the group 1 OPERATING DATA (excluding parameters 0134 PROCESS VAR 1 and 0135 PROCESS VAR 2).										
3408	P VAR 2 MULTIP Process variable 2 multiplier.										
3409	P VAR 2 DIVISOR Process variable 2 divider.										
3410	P VAR 2 SCALING Decimal point location of process variable 2, when displayed.										

Example. Assume that a two pole motor is directly connected to a roll 0.1 m in diameter and the line speed is to be displayed in m/s. Since 1 Hz output equals 1 rev/s, equals $\pi \cdot 0.1$ m/s line speed, or approximately 0.314 m/s, is:

$$\text{line speed} = \frac{\text{output freq} \cdot 314}{1000} \text{ m/s}$$

The following settings are then needed:

3402 P VAR 1 SEL = 0103 (OUTPUT FREQ)

3403 P VAR 1 MULTIP = 314

3404 P VAR 1 DIVISOR = 1000

3405 P VAR 1 SCALING = 1

Check what is the decimal point location on variable selected with parameter 3402 P VAR 1 SEL.

In this case the chosen variable 0103 OUTPUT FREQ is displayed with 0.1 Hz resolution. Therefore 3405 = 1 must be selected. See Figure 21.

Group 40: PID Control

The PID Control Macro allows the ACS 160 to take a reference signal (setpoint) and an actual signal (feedback), and automatically adjust the speed of the drive to match the actual signal to the reference.

There exist two PID parameter sets (group 40 for set 1 parameters and group 41 for set 2 parameters). Normally only set 1 parameters are used. Set 2 parameters can be taken in use by parameter 4016 PID PARAM SET. Selection between parameter sets can be done eg. through a digital input.

PID sleep function can be used to stop the regulation when the output of the PID controller falls below preset limit. Regulation is resumed when the process actual value falls below preset limit. Alternatively, sleep function can be activated and deactivated through a digital input.

Figure 31 (Appendix A) shows the connections of internal signals when the PID Control macro is selected.

Code	Description
4001	<p>PID GAIN This parameter defines the gain of the PID Controller. The setting range is 0.1... 100. If you select 1, a 10 % change in error value causes the PID Controller output to change by 10 %.</p>
4002	<p>PID INTEG TIME PID controller integration time. Defined as the time in which the maximum output is achieved if a constant error value exists and the gain is 1. Integration time 1 s denotes that a 100 % change is achieved in 1 s.</p>

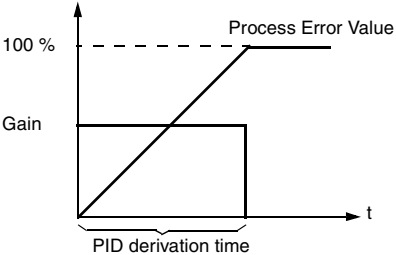
Code	Description
4003	<p>PID DERIV TIME PID controller derivation time. If the process error value changes linearly, D part adds a constant value into the PID controller output. The derivative is filtered with a 1-pole filter. The time constant of the filter is defined by parameter 4004 PID DERIV FILTER.</p> 
4004	<p>PID DERIV FILTER Time constant for the filter of D part. By increasing the filter time constant it is possible to smooth the effect of the D part and suppress noise.</p>
4005	<p>ERROR VALUE INV Process error value inversion. Normally, a decrease in feedback signal causes an increase in drive speed. If a decrease in feedback signal is desired to cause a decrease in speed, set ERROR VALUE INV to 1 (YES).</p> <p>0 = NO 1 = YES</p>
4006	<p>ACTUAL VAL SEL PID controller feedback (actual) signal selection. Feedback signal can be a combination of two actual values ACT1 and ACT2. Source for actual value 1 is selected by parameter 4007 and source for actual value 2 is selected by parameter 4008.</p> <p>1 = ACT1 Actual value 1 is used as the feedback signal.</p> <p>2 = ACT1-ACT2 Difference of actual values 1 and 2 is used as the feedback signal.</p> <p>3 = ACT1+ACT2 Sum of actual values 1 and 2.</p> <p>4 = ACT1*ACT2 Product of actual values 1 and 2.</p> <p>5 = ACT1/ACT2 Quotient of actual values 1 and 2.</p> <p>6 = MIN (A1, A2) Smaller of actual values 1 and 2.</p> <p>7 = MAX (A1, A2) Greater of actual values 1 and 2.</p> <p>8 = sqrt (A1-A2) Square root of difference of actual values 1 and 2.</p> <p>9 = sqA1 + sqA2 Sum of square roots of actual values 1 and 2.</p>

Code	Description
4007	ACT1 INPUT SEL Source for actual value 1 (ACT1). 1 = AI 1 Analogue input 1 is used as actual value 1. 2 = AI 2 Analogue input 2 is used as actual value 1.
4008	ACT2 INPUT SEL Source for actual value 2 (ACT2). 1 = AI 1 Analogue input 1 is used as actual value 2. 2 = AI 2 Analogue input 2 is used as actual value 2.
4009	ACT1 MINIMUM Minimum value for actual value 1 (ACT1). Refer to Figure 22 and to Group 13 parameters for analogue input minimum and maximum settings.
4010	ACT1 MAXIMUM Maximum value for actual value 1 (ACT1). Refer to Figure 22 and to Group 13 parameters for analogue input minimum and maximum settings.
4011	ACT2 MINIMUM Minimum value for actual value 2 (ACT2). Refer to parameter 4009.
4012	ACT2 MAXIMUM Maximum value for actual value 2 (ACT2). Refer to parameter 4010.

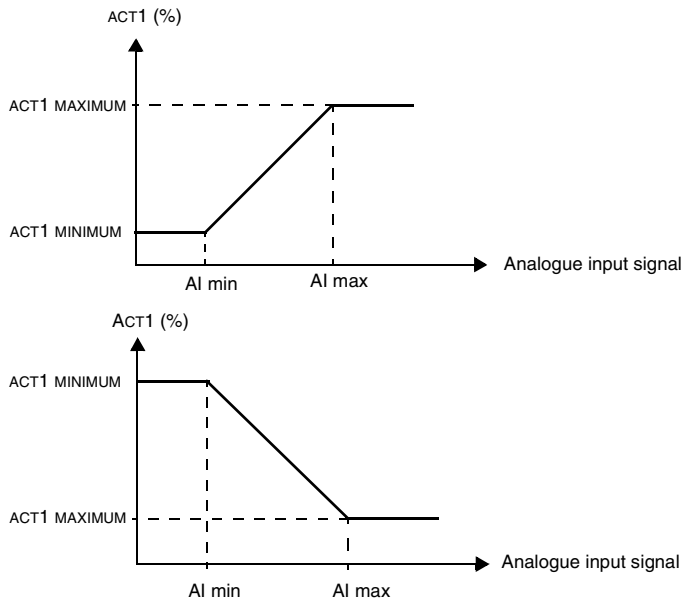

Figure 22 Actual value scaling. The range of the analogue input signal is set by parameters 1301 and 1302 or parameters 1304 and 1305, depending on the analogue input used.

Code	Description
4013	<p>PID SLEEP DELAY Time delay for the sleep function, see Figure 23. If the ACS 160 output frequency is below a set level (parameter 4014 SLEEP LEVEL) longer than PID SLEEP DELAY, ACS 160 is stopped. Alarm 28 is displayed when PID sleep is active.</p>
4014	<p>PID SLEEP LEVEL Level for activation of sleep function, see Figure 23. When the ACS 160 output frequency falls below the sleep level, the sleep delay counter is started. When the ACS 160 output frequency rises above the sleep level, the sleep delay counter is reset.</p>
4015	<p>WAKE-UP LEVEL Level for deactivation of sleep function. This parameter sets a process actual value limit for the sleep function (see Figure 23). The limit floats with the process reference.</p> <p>Non-inverted error value Applied wake-up level is according to the following formula: Limit = parameter 1107 + parameter 4015 * (set point - parameter 1107) / (parameter 1108 - parameter 1107)</p> <p>When the actual value is less than or equal to this value, the sleep function is deactivated. See Figure 24 and Figure 26.</p> <p>Inverted error value Applied wake-up level is according to the following formula: Limit = parameter 1108 + parameter 4015 * (parameter 1108 - setpoint) / (parameter 1108 - parameter 1107)</p> <p>When the actual value is higher than or equal to this value, the sleep function is deactivated. See Figure 25 and Figure 27.</p>
4016	<p>PID PARAM SET PID parameter set selection. When set 1 is selected, parameters 4001-4012 and 4019-4020 are used. When set 2 is selected, parameters 4101-4112 and 4119-4120 are used. 1...5 = DI1...DI5 PID parameter set is selected through a digital input (DI1...DI5). Parameter set 1 is used when the digital input is not active. Parameter set 2 is used when the digital input is active. 6 = SET 1 PID parameter set 1 is active. 7 = SET 2 PID parameter set 2 is active.</p>
4017	<p>WAKE-UP DELAY Delay for deactivation of PID sleep function. Refer to parameter 4015 WAKE-UP LEVEL and Figure 23.</p>
4018	<p>SLEEP SELECTION PID sleep function control. 0 = INTERNAL When INTERNAL is selected, the sleep state is controlled by the output frequency, process reference and process actual value. Refer to parameters 4015 WAKE-UP LEVEL and 4014 PID SLEEP LEVEL. 1...5 = DI1...DI5 Sleep state is activated and deactivated using a digital input.</p>

Code	Description
4019	<p>SET POINT SEL Set point selection. Defines the reference signal source for the PID controller.</p> <p>Note! When PID regulator is by-passed (parameter 8121 REG BYPASS CTRL), this parameter has no significance.</p> <p>1 = INTERNAL Process reference is a constant value set with parameter 4020 INTERNAL SETPNT.</p> <p>2 = EXTERNAL Process reference is read from a source defined with parameter 1106 EXT REF2 SELECT. The ACS 160 must be in remote mode (REM is shown on control panel display).*</p> <p>* Process reference to PID controller can also be given from the control panel in local mode (LOC is shown on control panel display) if the panel reference is given as percentage, i.e. value of parameter 1101 KEYPAD REF SEL = 2 (REF2 (%)).</p>
4020	<p>INTERNAL SETPNT Sets a constant process reference (%) for the PID controller. PID controller follows this reference if parameter 4019 SET POINT SEL is set to 1 (INTERNAL).</p>

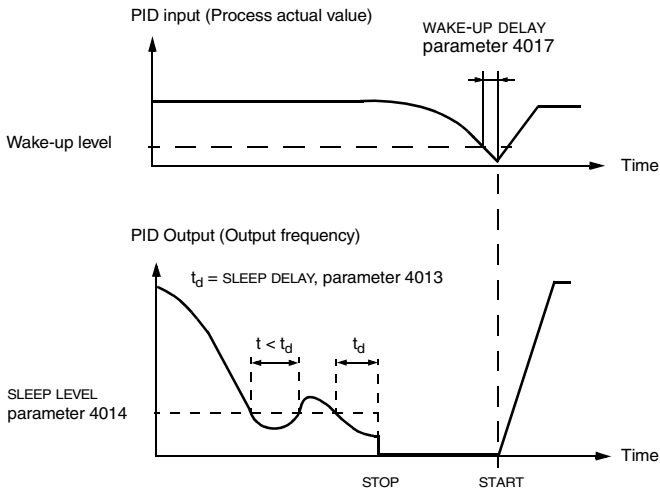

Figure 23 Sleep function operation.

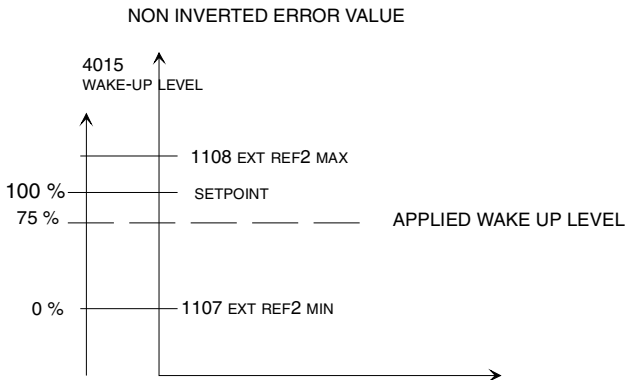

Figure 24 Example of how the applied wake-up level floats with the set point, here parameter 4015 WAKE-UP LEVEL equals to 75 %, PID control non-inverted case.

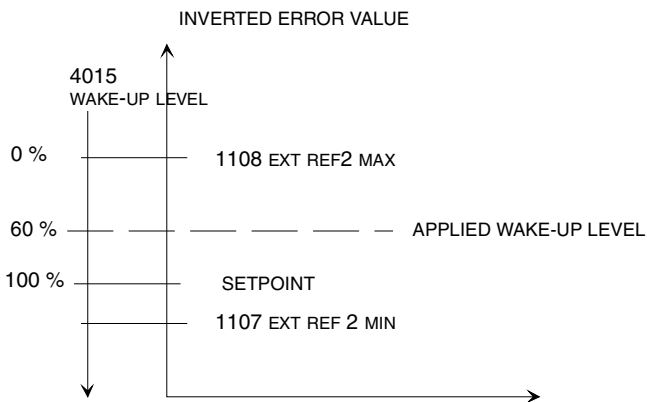

Figure 25 Example of how applied wake-up level floats with the set point, here parameter 4015 WAKE-UP LEVEL equals to 60 %, PID control inverted case.

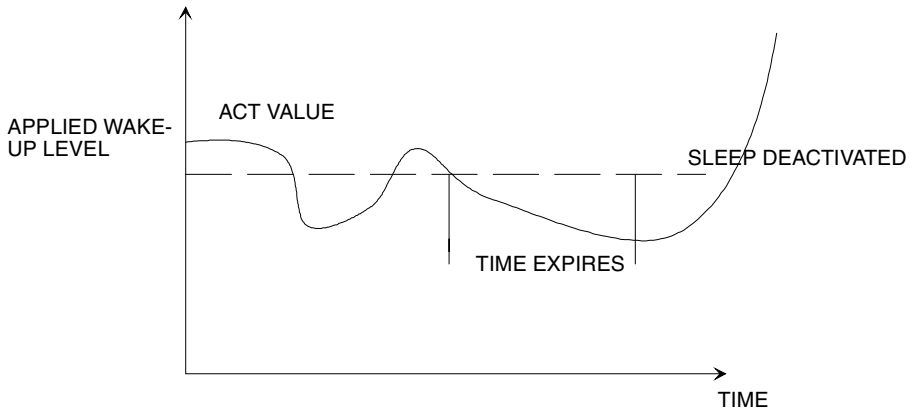

Figure 26 Wake-up level operation with non-inverted error value.

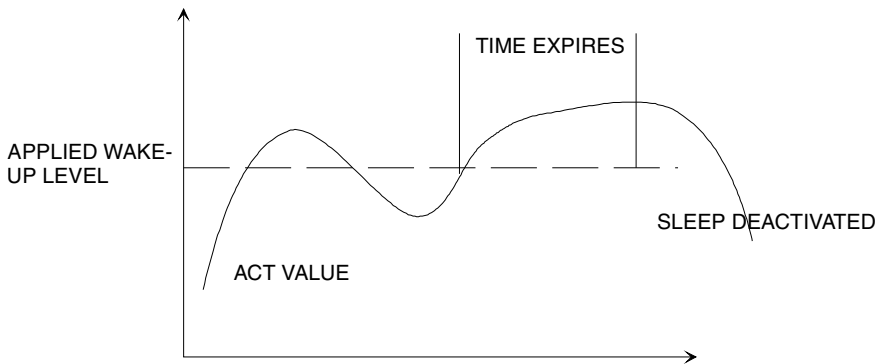

Figure 27 Wake-up level operation with inverted error value.

Group 41: PID Control (2)

Parameters of this group belong to PID parameter set 2. The operation of parameters 4101 - 4112, 4119 - 4120 is analogous with set 1 parameters 4001 - 4012, 4019 - 4020.

PID parameter set 2 can be selected by parameter 4016 PID PARAM SET.

Group 51: Ext Comm Module

Parameters of this group need to be adjusted only when an external fieldbus communication module is installed. Refer to communication module documentation for more information on these parameters. For standard Modbus communication, see Group 52.

Parameters 5204 COMM FAULT TIME and 5205 COMM FAULT FUNC can be used to detect communication loss between the drive and the fieldbus communication module.

Code	Description																						
5101	<p>FIELDBUSPAR 1 Parameter 1 of the fieldbus adapter module. Value reflects the type of adapter connected.</p> <p>Table 4 List of module types.</p> <table border="1"> <thead> <tr> <th>Value</th> <th>Module type</th> </tr> </thead> <tbody> <tr> <td>0</td> <td>No module connected.</td> </tr> <tr> <td>1</td> <td>Profibus (CFB-PDP)</td> </tr> <tr> <td>2</td> <td>Modbus *</td> </tr> <tr> <td>3</td> <td>Interbus-S (CFB-IBS)</td> </tr> <tr> <td>4</td> <td>CS31 bus *</td> </tr> <tr> <td>5</td> <td>CANopen (CFB-CAN)</td> </tr> <tr> <td>6</td> <td>DeviceNet (CFB-DEV)</td> </tr> <tr> <td>7</td> <td>LONWORKS (CFB-LON)</td> </tr> <tr> <td>8</td> <td>Modbus+ *</td> </tr> <tr> <td>9</td> <td>Others *</td> </tr> </tbody> </table> <p>* Reserved</p>	Value	Module type	0	No module connected.	1	Profibus (CFB-PDP)	2	Modbus *	3	Interbus-S (CFB-IBS)	4	CS31 bus *	5	CANopen (CFB-CAN)	6	DeviceNet (CFB-DEV)	7	LONWORKS (CFB-LON)	8	Modbus+ *	9	Others *
Value	Module type																						
0	No module connected.																						
1	Profibus (CFB-PDP)																						
2	Modbus *																						
3	Interbus-S (CFB-IBS)																						
4	CS31 bus *																						
5	CANopen (CFB-CAN)																						
6	DeviceNet (CFB-DEV)																						
7	LONWORKS (CFB-LON)																						
8	Modbus+ *																						
9	Others *																						
5102 - 5115	<p>FIELDBUSPAR 2 - FIELDBUSPAR 15 Refer to communication module documentation for more information on these parameters.</p>																						

Group 52: Standard Modbus

The ACS 160 features one serial link connector which can be used for control panel, for Modbus communication and for other fieldbus adapters. When standard Modbus communication is used parameters 5201 - 5203 are used to set up station number, communication speed and parity. An adapter is required to connect the ACS 160 either to RS232 or to RS485 type bus (type code CFB-RS).

It is also possible to connect the ACS 160 to other fieldbus systems, for example Profibus. For this purpose a fieldbus adapter is required that is able to convert the external fieldbus protocol to the standard Modbus protocol. Fieldbus communication modules of this kind are set up using Group 51 parameters.

Note! Modifications of parameters 5201 - 5203 take effect on the next power-up. Modification of station number, communication speed or parity may cause the communication to control panel or fieldbus adapter not to operate if they are connected after the drive is powered up. It is however always possible to ensure that communication starts operating simply by turning the power off from the drive, ensuring that the control panel or desired fieldbus adapter is connected, and then turning the power on again.

Code	Description
5201	STATION NUMBER Sets the slave number for the ACS 160 in Modbus network. Range: 1 - 247
5202	COMM SPEED Defines the communication speed of the ACS 160 in bits per second (bits/s). 3 = 300 bits/s 48 = 4800 bits/s 6 = 600 bits/s 96 = 9600 bits/s 12 = 1200 bits/s 192 = 19200 bits/s 24 = 2400 bits/s
5203	PARITY Defines the parity to be used with the Modbus communication. Parameter also defines the number of stop bits. With Modbus communication, the number of stop bits is 2 with no parity bit, and 1 with even or odd parity. 0 = NONE 1 = EVEN 2 = ODD
5204	COMM FAULT TIME Communication time out delay. When communication link is lost after the time set by COMM FAULT TIME, the communication fault function is activated. Parameter 5205 COMM FAULT FUNC.

Code	Description
5205	<p>COMM FAULT FUNC Communication fault function.</p> <p>0 = NOT SEL No operation.</p> <p>1 = FAULT A fault indication is displayed and the ACS 160 coasts to stop.</p> <p>2 = CONST SP 7 A warning indication is displayed and the speed is set according to parameter 1208 CONST SPEED7.</p> <p>3 = LAST SPEED A warning indication is displayed and the speed is set to the level the ACS 160 was last operating at. This value is determined by the average speed over the last 10 seconds.</p> <p>Caution: If you select CONST SPEED 7 or LAST SPEED, make sure that it is safe to continue operation in case communication is lost.</p>
5206	<p>BAD MESSAGES This diagnostics counter increases by one every time the ACS 160 finds any kind of communication error. During normal operation, this counter hardly ever increases.</p>
5207	<p>GOOD MESSAGES This diagnostics counter increases by one every time a valid Modbus message has been received by the ACS 160. During normal operation, this counter is increasing constantly.</p>
5208	<p>BUFFER OVERRUNS Longest possible message length for the ACS 160 is 32 bytes. If a message exceeding 32 bytes is received, this diagnostic counter increases by one every time a character which cannot be placed in the buffer is received.</p>
5209	<p>FRAME ERRORS This diagnostic counter increases by one every time when a character with a framing error is received from the bus.</p> <ul style="list-style-type: none"> • Communication speed settings of the devices connected in the bus differ. • Ambient noise levels may be too high.
5210	<p>PARITY ERRORS This diagnostic counter increases by one every time when a character with a parity error is received from the bus.</p> <ul style="list-style-type: none"> • Parity settings of the devices connected on the bus differ. • Ambient noise levels may be too high.
5211	<p>CRC ERRORS This diagnostic counter increases by one every time when a message with a CRC error is received.</p> <ul style="list-style-type: none"> • Ambient noise levels may be too high. • CRC calculation is not performed correctly.
5212	<p>BUSY ERRORS This diagnostic counter increases by one every time the ACS 160 receives a character from the bus while it is still processing the previous message.</p> <ul style="list-style-type: none"> • There might be two stations with the same station number. • Ambient noise levels may be too high.
5213	<p>SER FAULT MEM 1 Last Modbus exception code sent.</p>
5214	<p>SER FAULT MEM 2 Previous Modbus exception code sent.</p>
5215	<p>SER FAULT MEM 3 Oldest Modbus exception code sent.</p>

Group 54: Braking (Electromechanical Brake Control)

The versatile braking features of the ACS 160 include capability to control electromechanical brake. Electromechanical brake can be controlled by using programmable relay outputs of the ACS 160. The brake is applied when the motor is in stop (the relay output is de-energised).

Electromechanical brake control is enabled by first setting parameter 1401 RELAY OUTPUT 1 (or 1402 RELAY OUTPUT 2) to value 32 (MEC BR CNTRL). Parameters 5401 MBRK OPEN DLY and 5403 MBRK FREQ LVL are used to adjust the operation of the mechanical brake. Refer to Figure 28.

Note! Observe the relay output ratings as given in Reference Section **K**. When necessary, use an additional contactor to supply the brake coil.

Code	Description
5401	MBRK OPEN DLY Release delay for external brake. This delay specifies the time which passes from the brake open command to the moment when the brake is mechanically open. Note! Value of this parameter should be slightly longer than the actual time it takes for the external brake to release. Too large of a value may lead to overcurrent tripping as the motor shaft can not rotate due to operation of the brake.
5403	MBRK FREQ LVL The level of output frequency below which the external brake is applied. This frequency level should be low enough that the speed of the motor is reduced almost to zero during the closing delay of the external brake.

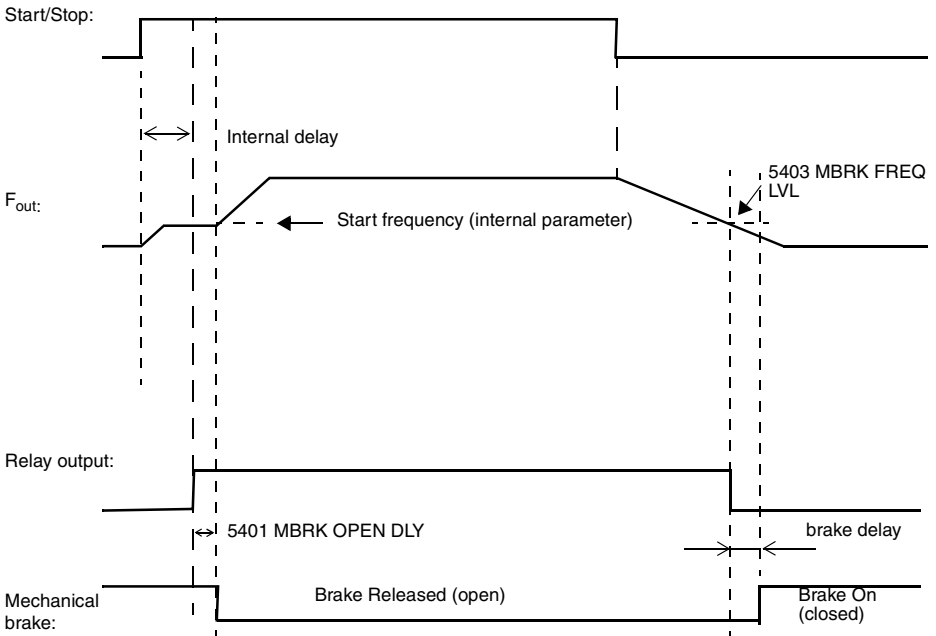

Figure 28 Operation of the electromechanical brake control.

Note! Described functionality is valid from ACS 160 SW version 1.0.0.F.

Group 82: Positioning

Built-in positioning features of the ACS 160 make it possible to use the drive in simple positioning applications, in many cases without an external PLC. Possible application examples are indexing systems and positioning systems with two absolute positions. Homing functions are also available. Operation can be combined with electromechanical brake and with dynamic braking.

Default operation of the Positioning Macro is described in Application Macro section.

Note! After selecting Positioning Macro by setting parameter 9902 APP MACRO = 14 (POSITIONING), the drive must be switched off and then on again. When Positioning Macro is selected the analogue output AO1 is not operational.

- To use positioning the ACS 160 must be equipped with an incremental pulse encoder. Parameters 8201 -8204 are used to configure it. See Table 5 for encoder specifications.
- Positioning mode is selected using parameter 8215 POS MODE. In positioning mode the drive must be controlled from external control location EXT2 (starting from SW revision 1.0.0.F).
- Tuning parameters 8218 SLOPE GAIN 1, 8220 SPEED GAIN 1 and 8229 DELTA DISTANCE are used to optimise the operation when approaching the target position.
- Parameter 8216 HOMING MODE tells how the system should find its initial position when power is turned on. In the simplest systems homing is not needed.
- There are two position reference sets. Both include target position and separate speed profiles. The position reference selection mechanism is configured using parameter 8206 POS TABLE SEL.
- Two ACS160 parameter locations are needed per position: Most significant part of a position is given as full revolutions of the axis, and least significant part is given as multiples of 1/65536 of one axis revolution.

Example

Target 1 is at the distance of 52 full axis revolutions plus one quarter of a revolution. In this case, target is stored as:

Parameter 8207 TARGET 1 LO = $1/4 * 65536 = 16384$

Parameter 8208 TARGET 1 HI = 52

Note! Due to four segment panel display, the displayed value needs to be multiplied by 10, when the parameter values goes over 9999.

Table 5 Encoder specifications

Supply voltage	24 V from terminals X1:9 (+24 V) and X1:8 (GND)
Max. current consumption	100 mA
Encoder outputs	Connected to terminals X1:14 (DI4) and X1:15 (DI5). Signal leads with opposite phase are not used
Max. encoder cable length	3 m
Max. pulse frequency	200 kHz

For further information please contact your local ABB supplier.

Code	Description
8201	ENC PULSE NUM Number of encoder pulses per revolution.
8202	ENC ERROR Defines the action of the ACS 160 in encoder error situation. 0 = NOT SEL Encoder error supervision disabled. 1 = FAULT The drive is stopped with coast stop and fault indication is given when the following conditions are fulfilled: <ul style="list-style-type: none"> • drive is running and output frequency is over 0 Hz. • no encoder pulses are detected for the time defined with parameter 8203 ENC DELAY.
8203	ENC DELAY The delay before the encoder fault is given. See parameter 8202 ENC ERROR.
8204	ENC SCALING Sets the counting direction for the position counter. 0 and positive values = DIRECTION 1. Negative values = DIRECTION 2 Example: If motor is rotating in forward direction and position counter value is counting in positive direction (see parameters 8227 POS ACT LO and 8228 POS ACT HI) DIRECTION 1 is selected. Otherwise DIRECTION 2 must be selected.

Code	Description																																																
8206	<p>POS TABLE SEL Position reference set selection.</p> <p>1 = REF SET 1 Reference set 1 is used.</p> <p>2 = REF SET 2 Reference set 2 is used.</p> <p>3 = AI2 Reference set is selected with analogue input 2 (AI2):</p> <ul style="list-style-type: none"> AI2 = 0...5 V (0...10 mA): Reference set 1 is selected. AI2 = 5...10 V (10...20 mA): Reference set 2 is selected. <p>4 = DI2 Reference set is selected with digital input 2 (DI2):</p> <ul style="list-style-type: none"> DI2 is inactive: Reference set 1 is selected. DI2 is active: Reference set 2 is selected. <p>5 = DI3 Reference set is selected with digital input 3 (DI3):</p> <ul style="list-style-type: none"> DI3 is inactive: Reference set 1 is selected. DI3 is active: Reference set 2 is selected. <p>Table 6 Reference sets when parameter 8206 = 1...5</p> <table border="1"> <thead> <tr> <th></th> <th>Reference Set 1</th> <th>Reference Set 2</th> </tr> </thead> <tbody> <tr> <td>Target position, low-part</td> <td>TARGET 1 LO (8207)</td> <td>TARGET 2 LO (8209)</td> </tr> <tr> <td>Target position, high-part</td> <td>TARGET 1 HI (8208)</td> <td>TARGET 2 HI (8210)</td> </tr> <tr> <td>Positioning frequency reference</td> <td>CONST SPEED 1 (1202)</td> <td>CONST SPEED 2 (1203)</td> </tr> <tr> <td>Target window frequency reference</td> <td>CONST SPEED 3 (1204)</td> <td>CONST SPEED 3 (1204)</td> </tr> <tr> <td>Homing frequency reference</td> <td>CONST SPEED 6 (1207)</td> <td>CONST SPEED 6 (1207)</td> </tr> <tr> <td>Acceleration time</td> <td>ACCELER TIME 1 (2202)</td> <td>ACCELER TIME 2 (2204)</td> </tr> <tr> <td>Deceleration time</td> <td>DECELER TIME 1 (2203)</td> <td>DECELER TIME 2 (2205)</td> </tr> </tbody> </table> <p>6 = SET 1 + EXT F Reference set 1 is used, except the positioning frequency reference is selected with parameter 1106 EXT REF2 SELECT.</p> <p>7 = SET 2 + EXT F Reference set 2 is used, except the positioning frequency reference is selected with parameter 1106 EXT REF2 SELECT.</p> <p>Table 7 Reference sets when parameter 8206 = 6,7</p> <table border="1"> <thead> <tr> <th></th> <th>Reference Set 1</th> <th>Reference Set 2</th> </tr> </thead> <tbody> <tr> <td>Target position, low-part</td> <td>TARGET 1 LO (8207)</td> <td>TARGET 2 LO (8209)</td> </tr> <tr> <td>Target position, high-part</td> <td>TARGET 1 HI (8208)</td> <td>TARGET 2 HI (8210)</td> </tr> <tr> <td>Positioning frequency reference</td> <td>EXT REF2 SELECT (1106) *</td> <td>EXT REF2 SELECT (1106) *</td> </tr> <tr> <td>Target window frequency reference</td> <td>CONST SPEED 3 (1204)</td> <td>CONST SPEED 3 (1204)</td> </tr> <tr> <td>Homing frequency reference</td> <td>CONST SPEED 6 (1207)</td> <td>CONST SPEED 6 (1207)</td> </tr> <tr> <td>Acceleration time</td> <td>ACCELER TIME 1 (2202)</td> <td>ACCELER TIME 2 (2204)</td> </tr> <tr> <td>Deceleration time</td> <td>DECELER TIME 1 (2203)</td> <td>DECELER TIME 2 (2205)</td> </tr> </tbody> </table> <p>Note! * When Ext Ref 2 is selected then values 0, 1 and 2 are only ones allowed for parameter 1106. Parameter 1201 CONST SPEED SEL must be set to 0 (NOT SEL). Parameter 2201 ACC/DEC 1/2 SELECT must be set to 0 (NOT SEL). Frequency reference, acceleration and deceleration times can be set only when the drive is stopped.</p>		Reference Set 1	Reference Set 2	Target position, low-part	TARGET 1 LO (8207)	TARGET 2 LO (8209)	Target position, high-part	TARGET 1 HI (8208)	TARGET 2 HI (8210)	Positioning frequency reference	CONST SPEED 1 (1202)	CONST SPEED 2 (1203)	Target window frequency reference	CONST SPEED 3 (1204)	CONST SPEED 3 (1204)	Homing frequency reference	CONST SPEED 6 (1207)	CONST SPEED 6 (1207)	Acceleration time	ACCELER TIME 1 (2202)	ACCELER TIME 2 (2204)	Deceleration time	DECELER TIME 1 (2203)	DECELER TIME 2 (2205)		Reference Set 1	Reference Set 2	Target position, low-part	TARGET 1 LO (8207)	TARGET 2 LO (8209)	Target position, high-part	TARGET 1 HI (8208)	TARGET 2 HI (8210)	Positioning frequency reference	EXT REF2 SELECT (1106) *	EXT REF2 SELECT (1106) *	Target window frequency reference	CONST SPEED 3 (1204)	CONST SPEED 3 (1204)	Homing frequency reference	CONST SPEED 6 (1207)	CONST SPEED 6 (1207)	Acceleration time	ACCELER TIME 1 (2202)	ACCELER TIME 2 (2204)	Deceleration time	DECELER TIME 1 (2203)	DECELER TIME 2 (2205)
	Reference Set 1	Reference Set 2																																															
Target position, low-part	TARGET 1 LO (8207)	TARGET 2 LO (8209)																																															
Target position, high-part	TARGET 1 HI (8208)	TARGET 2 HI (8210)																																															
Positioning frequency reference	CONST SPEED 1 (1202)	CONST SPEED 2 (1203)																																															
Target window frequency reference	CONST SPEED 3 (1204)	CONST SPEED 3 (1204)																																															
Homing frequency reference	CONST SPEED 6 (1207)	CONST SPEED 6 (1207)																																															
Acceleration time	ACCELER TIME 1 (2202)	ACCELER TIME 2 (2204)																																															
Deceleration time	DECELER TIME 1 (2203)	DECELER TIME 2 (2205)																																															
	Reference Set 1	Reference Set 2																																															
Target position, low-part	TARGET 1 LO (8207)	TARGET 2 LO (8209)																																															
Target position, high-part	TARGET 1 HI (8208)	TARGET 2 HI (8210)																																															
Positioning frequency reference	EXT REF2 SELECT (1106) *	EXT REF2 SELECT (1106) *																																															
Target window frequency reference	CONST SPEED 3 (1204)	CONST SPEED 3 (1204)																																															
Homing frequency reference	CONST SPEED 6 (1207)	CONST SPEED 6 (1207)																																															
Acceleration time	ACCELER TIME 1 (2202)	ACCELER TIME 2 (2204)																																															
Deceleration time	DECELER TIME 1 (2203)	DECELER TIME 2 (2205)																																															

Code	Description
8207	TARGET 1 LO
8208	TARGET 1 HI Target position 1 reference values. See example on page 100.
8209	TARGET 2 LO
8210	TARGET 2 HI Target position 2 reference values. See example on page 100.
8213	POS DELAY Stop delay scaling factor at positioning mode 9. Stop time at turning points can be scaled with this parameter. If the parameter value is zero, then the delay is always zero. Delay [ms] = POS DELAY * 40 / Positioning frequency reference (Hz).
8215	POS MODE Positioning mode selection. 4 = RELAT MOVE1 Selected target position is relative to previous target position. When start command is given, the position counter is first reset to zero and then corrected with the distance between actual and desired stopping position. The purpose of this is to prevent the axis to "creep" from its original home position. Correction is only made, when the previous move has reached the target window area. If two targets are used, make sure that target reference is changed only at stop-state! 5 = ABS MOVE 1 Selected target position is absolute. Position counter is not reset when start command is given. This mode is typically used when the load is moved between two positions. 6 = ABS MOVE CC1 Basic operation as in mode 5. Cyclic correction added. Positioning counter is set to the value of home position parameters 8225 HOME POS LO and 8226 HOME POS HI, when digital input 3 (DI3) state changes from inactive to active state. 7 = ABS MOVE CC2 Basic operation as in mode 5. Cyclic correction added. Positioning counter is set to the value of home position parameters 8225 HOME POS LO and 8226 HOME POS HI, when digital input 3 (DI3) state changes from active to inactive state. 8 = RELAT MOVE2 Same as mode 4, except that the position counter starts counting from the value set with parameters 8225 HOME POS LO and 8226 HOME POS HI every time when Start command is given. This position mode provides no position correction possibilities. 9 = CONT MOVE1 Selected target is absolute. Continuous move between home and target1 position. Used for example for spinning wires. A position time delay parameter 8213 POS DELAY and external frequency reference parameter 8217 AUX POS CMD can be defined.

Code	Description
8216	<p>HOMING MODE</p> <p>Homing mode is possible only when external control locations EXT2 is selected.</p> <p>0 = NOT SEL Homing is not used.</p> <p>1 - 3 = reserved</p> <p>4 = HOMING 1 Homing frequency reference is set with parameter 1207 CONST SPEED 6. Homing direction is defined with digital input 3 (DI3):</p> <ul style="list-style-type: none"> • direction is forward when DI3 is inactive. • direction is reverse when DI3 is active. <p>Home position is set to position counter when DI3 state changes. After this homing speed reference is internally forced to zero. Load decelerates from homing frequency to zero. Positioning is enabled when stop command is given.</p> <p>5 = HOMING 2 Like HOMING 1 with the following difference:</p> <ul style="list-style-type: none"> • direction is reverse when DI3 is inactive • direction is forward when DI3 is active <p>6 = HOMING 3 Like HOMING 4 and HOMING 5 with the exception that homing direction is defined with analogue input AI1:</p> <ul style="list-style-type: none"> • direction is forward when AI1 = 0...4 V (0...8 mA) • direction is reverse when AI1 = 6...10 V (12...20 mA). <p>Note! When value 4 or 5 is selected, the drive will perform homing operation when it is powered up and it receives the first start command. External control place EXT 2 must be selected. After the homing operation is completed the drive will go to positioning mode as set by parameter 8215 POS MODE.</p>
8217	<p>AUX POS CMD</p> <p>Auxiliary positioning mode commands selection.</p> <p>0 = NOT SEL</p> <p>1 = DI2 Digital input 2 (DI2) is used to give auxiliary positioning start/stop commands. This command does not start or stop the ACS 160 modulation. During homing this command acts only as start enable.</p> <p>2 = STOP 0 HZ Positioning frequency reference is set to 0 Hz when positioning target window has been reached.</p> <p>3 = STOP MODUL Modulation is stopped when positioning target window has been reached.</p> <p>4 = EXT FREQ Enables external frequency reference use at positioning mode 9. Frequency reference is selected with parameter 1106 EXT REF2 SELECT. Allowed selections: parameter 1106 (EXT REF2 SELECT) = 0,1 or 2 External frequency reference update can be controlled with digital input DI2:</p> <ul style="list-style-type: none"> • DI2 is inactive, frequency is sampled at turning points. • DI2 is active, frequency reference is sampled continuously.
8218	<p>SLOPE GAIN 1</p> <p>Frequency reference deceleration slope control. Values above 1000 delays the beginning of the deceleration ramp and make target position approach faster. Values below 1000 increase the effective deceleration time and make target position approach slower.</p>
8220	<p>SPEED GAIN 1</p> <p>Gain factor of positioning speed control during deceleration. Higher value means higher speed.</p>
8221	<p>T WINDOW LO</p>
8222	<p>T WINDOW HI</p> <p>Target position window limit, refer to example on page 100.</p> <p>Operation: When the actual value of position is inside the target area (target ref+- target window), the relay output is activated, if parameters 1401 RELAY OUTPUT 1 or 1402 RELAY OUTPUT 2 has value 34 (AT TARGET). The relay is deactivated when next position start command is given.</p>

Code	Description
8223	MAX TARGET LO
8224	<p>MAX TARGET HI Maximum target position limit, refer to example on page 100.</p> <p>Operation: When the absolute value goes above this limit, the output frequency is forced to 0 Hz. No alarm or fault indication is given.</p>
8225	HOME POS LO
8226	<p>HOME POS HI Home position, refer to example on page 100.</p> <p>This value is set to position counter in situations defined by parameters 8216 HOMING MODE and 8215 POS MODE.</p>
8227	POS ACT LO
8228	<p>POS ACT HI Position actual value, refer to example on page 100. Displays the actual position (read-only).</p>
8229	<p>DELTA DISTANCE Turning parameter. Use this together with parameters 8218 SLOPE GAIN 1 and 8220 SPEED GAIN1. If the position difference between two consecutive 4 ms time instances is smaller than this parameter value, the positioning speed is increased with the amount of parameter 8820 SPEED GAIN1 value. If the difference is greater then positioning speed is decreased.</p> <p>The purpose of parameters 8220 SPEED GAIN1 and 8229 DELTA DISTANCE is to make actual positioning speed near target depended on the load and to ensure that the target is reached.</p>

Diagnosics

General

This chapter describes the various alarm and fault codes and lists the most common causes for the particular display. If the fault cannot be cured by the given instructions, contact an ABB service representative.

Caution! Do not attempt any measurement, parts replacement or other service procedure not described in this manual. Such action will void guarantee, endanger correct operation, and increase downtime and expense.

Alarm and Fault displays

The seven-segment display unit of the control panel indicates alarms and faults using codes “ALxx” or “FLxx”, where xx is the corresponding alarm or fault code.

Alarms 1-7 arise from button operation.

The alarm and fault messages disappear when MENU, ENTER or the arrow buttons of control panel are pressed. The message will reappear after a few seconds if the keypad is not touched and the alarm or fault is still active.

Last three fault codes are stored into parameters 0128 - 0130. These fault memories can be cleared from the control panel by pressing UP and DOWN buttons simultaneously in parameter set mode or through serial communication mode by writing 0 into them.

Fault Resetting

Faults can be reset either from the control panel (by pressing START/STOP button), by digital input (Parameter 1604) or serial communication, or switching the supply voltage off for a while. When the fault has been removed, the motor can be started.

The ACS 160 can be configured to automatically reset certain faults. Refer to parameter group 31 AUTOMATIC RESET.

Warning! If an external source for start command is selected and it is active, the ACS 160 may start immediately after fault reset.

Warning! All electrical installation and maintenance work described in this chapter should only be undertaken by a qualified electrician. The Safety Instructions on the first pages of this manual must be followed.

Use of the ACS 160 without control panel

If no control panel or serial communication is in use and the fault persists, check the following:

- Motor cable connections for possible short circuit.
- The supply voltage and cables.
- If analogue input is used, check the DIP switch settings.

Table 8 Alarms

Alarm Code	Name	Description
1 *	OPERATION FAILED	Parameter upload or download failed. The software versions of the drives may not be compatible. Software version can be seen from parameter 3301 SOFTWARE VERSION.
2 *	START ACTIVE	Control panel function is not allowed while start is active.
3 *	LOCAL/REMOTE	Control panel function is not allowed in current control mode (local or remote). Control mode is local when LOC is displayed and remote mode when REM is displayed on the control panel.
5 *	BUTTON DISABLED	Control panel function is denied for any of the following reasons: <ul style="list-style-type: none"> START/STOP button is interlocked from digital input. This can happen with certain digital input configurations. Refer to section on Application Macros. REVERSE button is locked because shaft direction is fixed by parameter 1003 DIRECTION. The drive is in remote control mode and START/STOP and REVERSE buttons are not followed.
6 *	PARAM/LOCAL LOCK	Control panel function is not allowed: <ul style="list-style-type: none"> Parameter 1602 PARAMETER LOCK denies parameter editing Parameter 1605 LOCAL LOCK denies local control mode.
7 *	FACTORY MACRO	Control panel function is not allowed: Factory macro is selected and denies the parameter modifications. Factory macro is intended for applications where there is no control panel available.
10 **	OVERCURRENT	Overcurrent controller is active.
11 **	OVERVOLTAGE	Overvoltage controller is active.
12 **	DC UNDERVOLTAGE	Undervoltage controller is active.
13	DIRECTION LOCK	Rotation direction if fixed by parameter 1003 DIRECTION.
14	SERIAL COMM LOSS	Serial communication through Standard Modbus Channel is lost. <ul style="list-style-type: none"> Check connections between external control system and the ACS 160. Refer to parameters 5204 COMM FAULT TIME and 5205 COMM FAULT FUNC.
15 *, **	MODBUS EXCEPTION	Exception response is sent through Standard Modbus channel. The bus master may be sending queries which cannot be processed by the ACS 160. Last three exception response codes are stored into parameters 5213 - 5215.
16	AI1 LOSS	Analogue input 1 loss. Analogue input 1 value is less than MINIMUM AI1 (1301). See also parameter 3001 AI<MIN FUNCTION.
17	AI2 LOSS	Analogue input 2 loss. Analogue input 2 value is less than MINIMUM AI2 (1306). See also parameter 3001 AI<MIN FUNCTION.
18	PANEL LOSS	Panel communication loss. Control panel is disconnected when <ul style="list-style-type: none"> Drive is in local control mode (LOC is shown in the control panel display), or Drive is in remote control mode (REM) and is parameterised to accept start/stop, direction or reference from the panel. Refer to parameters in groups 10 COMMAND INPUTS and 11 REFERENCE SELECT. See also parameter 3002 PANEL LOSS.
19 **	ACS160 OVERTEMP	ACS 160 overtemperature condition. This alarm is given when the temperature reaches 95% of the trip limit.
20	MOTOR OVERTEMP	Motor overtemperature condition as estimated by the ACS 160. Refer to parameters 3004 – 3008.
21	UNDERLOAD	Motor load is too low. Check for a problem in the driven equipment. Refer to parameters 3013 – 3015.
22	MOTOR STALL	Motor is operating in the stall region. This may be caused by excessive load or insufficient motor power. Refer to parameters 3009 – 3012.
23		Reserved.
24		Reserved.

Alarm Code	Name	Description
25		Reserved.
26 **	OUTPUT OVERLOAD	Inverter overload condition. The ACS 160 output current exceeds the ratings given in Reference Section P.
27 *	AUTOMATIC RESET	ACS 160 is about to perform automatic fault reset operation. As a result, the drive may start after the reset operation. Refer to parameter group 31 AUTOMATIC RESET.
28 *	PID SLEEP	PID sleep function is active. The drive may accelerate when PID sleep function is deactivated. Refer to parameters 4018 SLEEP SELECTION, 4013 PID SLEEP DELAY, 4014 PID SLEEP LEVEL and 4015 WAKE-UP LEVEL.
29		Reserved.
30		Reserved.
31	BR RES OVERLOAD	Brake resistor is nearly overloaded. Refer to brake resistor instructions.

Note! Alarms (*) will not cause relay output RO1 (RO2) to activate when the relay output is configured to indicate alarm condition in general. (Parameter 1401 RELAY OUTPUT 1 (1402 RELAY OUTPUT 2) has value 5 (ALARM) or 13 (FLT/ALARM)).

Note! Alarms (**) will be shown only if parameter 1608 DISPLAY ALARMS is set to 1 (YES)

Table 9 Faults.

Fault Code	Name	Description
1	OVERCURRENT	Output current is excessive. <ul style="list-style-type: none"> Motor load may be too high Acceleration time may be too short (parameters 2201 ACCELER TIME 1 and 2203 ACCELER TIME 2). Motor or motor cable is faulty or connected wrong.
2	DC OVERVOLTAGE	Intermediate circuit DC voltage is excessive. <ul style="list-style-type: none"> Check mains for static or transient overvoltages Deceleration time may be too short (parameters 2202 DECELER TIME 1 and 2204 DECELER TIME 2) Brake chopper (if present) may be underdimensioned
3	ACS160 OVERTEMP	ACS 160 heat sink temperature is excessive. Temperature trip limit is 105 °C. <ul style="list-style-type: none"> Check air flow and fan operation. Check motor power against unit power.
4 **	SHORT CIRCUIT	Fault current. Possible reasons for this fault are: <ul style="list-style-type: none"> There is a short-circuit in the motor cable(s) or motor Supply disturbances
5	OUTPUT OVERLOAD	Inverter overload condition. The ACS 160 output current exceeds the ratings given in Reference Section P.
6	DC UNDERVOLTAGE	Intermediate circuit DC voltage is not sufficient. <ul style="list-style-type: none"> Mains phase may be missing Fuse may be blown
7	ANALOGUE INPUT 1	Analogue input 1 loss. Analogue input value is less than MINIMUM AI1 (1301). See also parameter 3001 AI<MIN FUNCTION.
8	ANALOGUE INPUT 2	Analogue input 2 loss. Analogue input value is less than MINIMUM AI2 (1306). See also parameter 3001 AI<MIN FUNCTION.
9	MOTOR OVERTEMP	Motor overtemperature condition as estimated by the ACS 160. Refer to parameters 3004 – 3008.
10	PANEL LOSS	Panel communication loss. Control panel is disconnected when the drive is receiving start, stop and direction commands from the panel. <ul style="list-style-type: none"> - Drive is in local control mode (LOC is shown in the control panel display), or - Drive is in remote control mode (REM is shown) and is parameterised to accept start/stop, direction or reference from the panel. Refer to parameters in groups 10 COMMAND INPUTS and 11 REFERENCE SELECT. See also parameter 3002 PANEL LOSS.
11	PARAMETERING	Parameter values are inconsistent: <ul style="list-style-type: none"> MINIMUM AI1 > MAXIMUM AI1 (parameters 1301, 1302) MINIMUM AI2 > MAXIMUM AI2 (parameters 1304, 1305) MINIMUM FREQ > MAXIMUM FREQ (parameters 2007, 2008)
12	MOTOR STALL	Motor stall. This may be caused by excessive load or insufficient motor power. Refer to parameters 3009 – 3012.
13	SERIAL COMM LOSS	Serial communication through Standard Modbus Channel is lost. <ul style="list-style-type: none"> Check connections between external control system and the ACS 160. Refer to parameters 5204 COMM FAULT TIME and 5205 COMM FAULT FUNC.
14	EXTERNAL FAULT SIGNAL	External fault is active. See parameter 3003 EXTERNAL FAULT.
15 **	OUTPUT EARTH FAULT	Earth fault. The load on the incoming mains system is out of balance. <ul style="list-style-type: none"> There may be a fault in the motor or motor cable. Motor cable may be too long.
16 **	DC BUS RIPPLE	<ul style="list-style-type: none"> Ripple voltages on the DC bus are too large. Mains phase may be missing Fuse may be blown

17	UNDERLOAD	Motor load is too low. Check for a problem in the driven equipment. Refer to parameters 3013 – 3015.
18		Reserved
19		Reserved.
20 **	AI OUT OF RANGE	Analogue input out of range. Check AI level.
21 - 29 **	HARDWARE ERROR	Hardware error. Contact supplier.
30	BR RES OVERLOAD	Brake resistor is overloaded. Refer to parameter 2005 OVERVOLT CTRL.
31	ENCODER FAULT	Positioning macro is used, but the drive is not receiving pulses. Check the encoder and its connections.
Full display blinking		Serial link failure. Bad connection between the control panel and the ACS 160.

Note! Faults (**) are indicated by a red blinking LED and are reset by turning the power off for a while.

Appendix A

Control signals

The drive can receive its control signals through the digital and analogue inputs, from the control panel or through serial communications. Using parameters in groups 10, 11, 12 and 16 it is possible to define sources for start and stop signal, direction, frequency reference, run enable signal, EXT1/EXT2 selection signal and for fault reset signal.

Figure 29 illustrates this principle, showing how the parameters are used to select sources for controlling signals.

By selecting application macro using parameter 9902 APP MACRO the values of the parameters are set to their macro dependent values. Figure 30 and Figure 31 show how drive's internal signals are affected when various macros are selected.

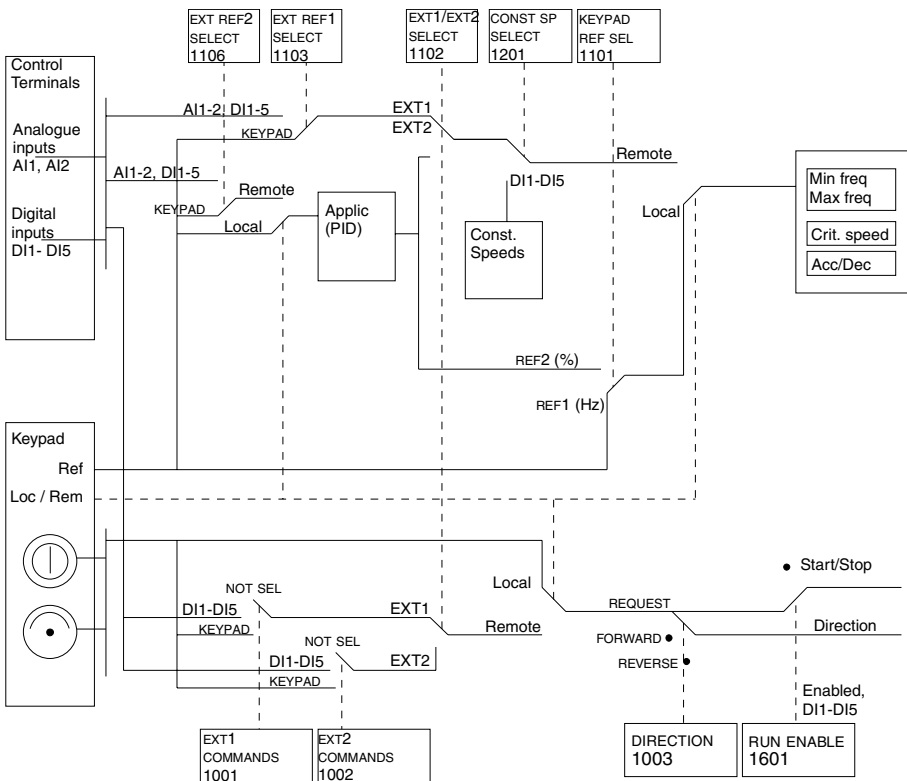

Figure 29 Selecting control location and control source.

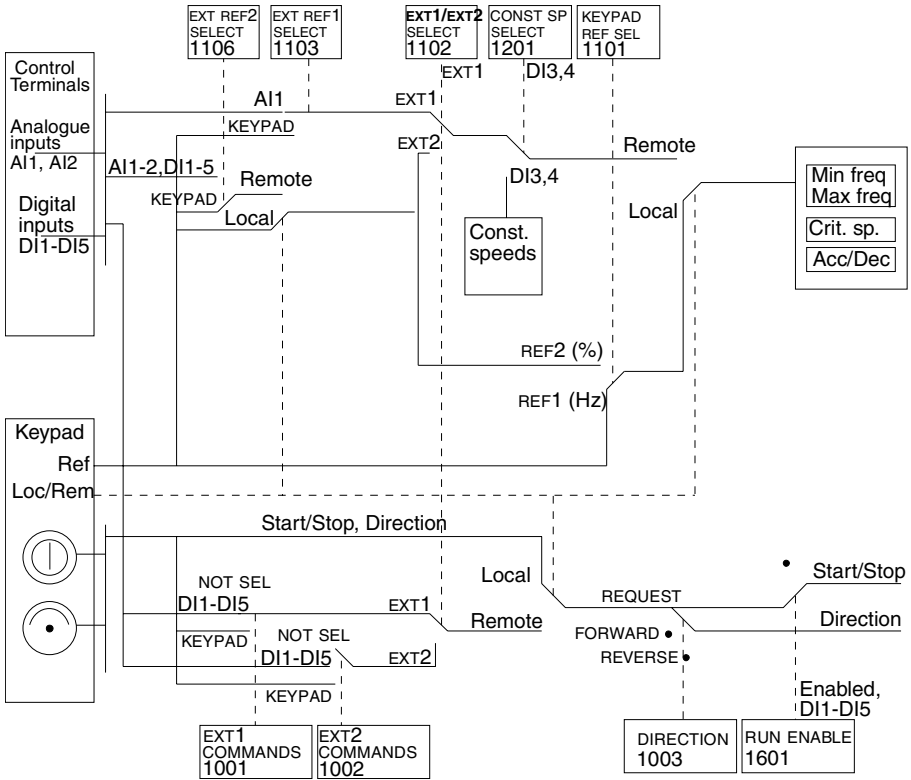

Figure 30 The control signal connections of the ABB Standard, Alternate and Premagnetise macros.

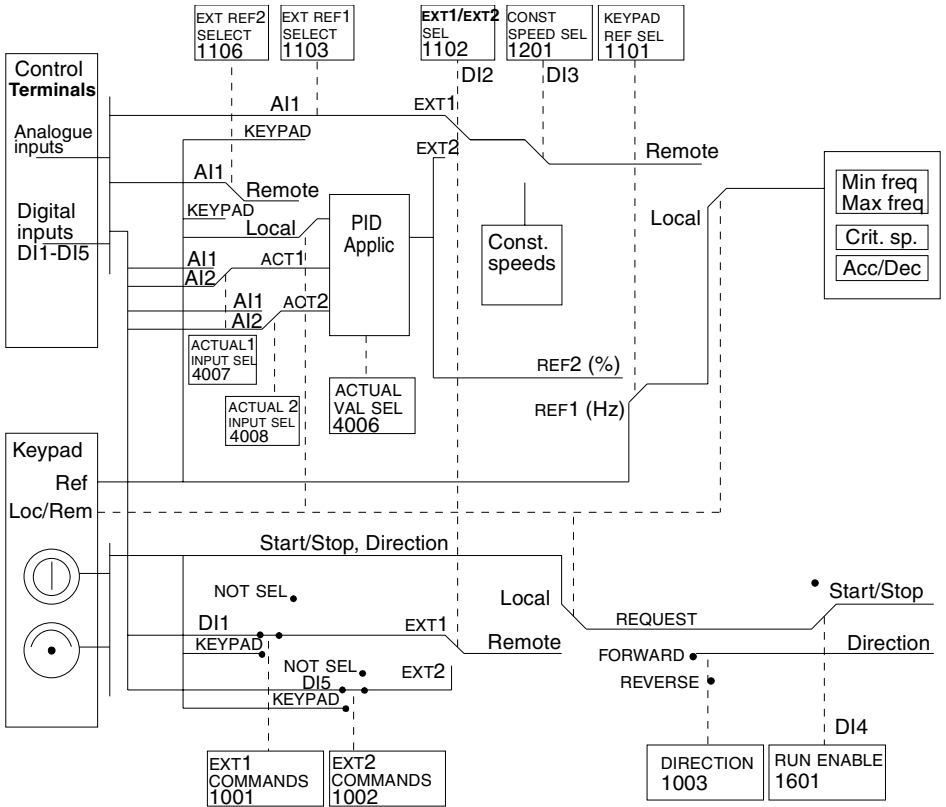
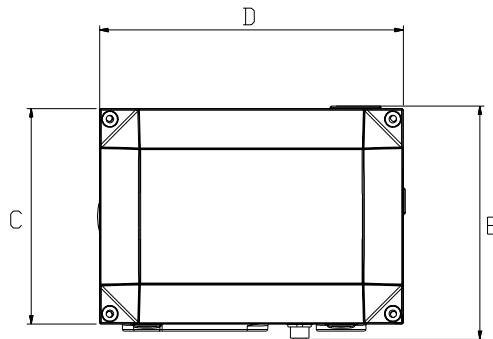
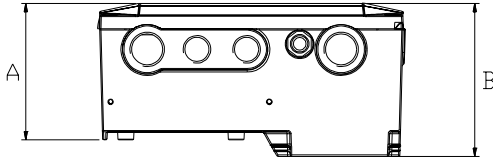

Figure 31 The control signal connections of the PID Control macro.

Appendix B

Dimensions

Motor Mounted



Converter type ACS 163-	Frame Size	A (mm)	B (mm)	C (mm)	D (mm)	E (mm)	Weight (kg)
1K1-3-A...2K7-3-A	R1	99	112	157	221	171	3.9
4K1-3-A	R2	99	112	157	261	171	4.6
1K1-3-B... 2K7-3-B	R1	135	149	157	221	171	5.5
4K1-3-B	R2	135	149	157	261	171	6.3

Converter type ACS 163-	Frame Size	A (in)	B (in)	C (in)	D (in)	E (in)	Weight (lb)
1K1-3-R...2K1-3-R	R1	3.9	4.4	6.2	8.7	6.7	8.6
4K1-3-R	R2	3.9	4.4	6.2	10.3	6.7	10.14
1K1-3-S... 2K1-3-S	R1	5.3	5.9	6.2	8.7	6.7	12.13
4K1-3-S	R2	5.3	5.9	6.2	10.3	6.7	13.89

Wall mounted

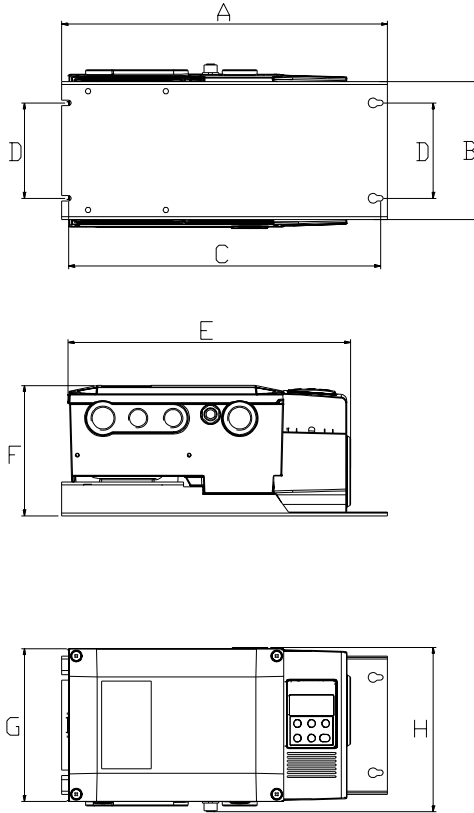

Converter type ACS 163-	Frame size	A (mm)	B (mm)	C (mm)	D (mm)	E (mm)	F (mm)	G (mm)	H (mm)	Weight (kg)
1K1-3-D...2K7-3-D	R1	317	149	303	98	290	134	157	171	5.1
4K1-3-D	R2	357	149	343	98	330	134	157	171	5.8
1K1-3-E... 2K7-3-E	R1	317	149	303	98	290	171	157	171	6.7
4K1-3-E	R2	357	149	343	98	330	171	157	171	7.5

Converter type ACS 163-	Frame size	A (in)	B (in)	C (in)	D (in)	E (in)	F (in)	G (in)	H (in)	Weight (lb)
1K1-3-U...2K1-3-U	R1	12.5	5.87	11.93	3.86	11.4	5.28	6.18	6.73	11.24
4K1-3-U	R2	14.1	5.87	13.5	3.86	13.0	5.28	6.18	6.73	12.79
1K1-3-V... 2K1-3-V	R1	12.5	5.87	11.93	3.86	11.4	6.73	6.18	6.73	14.77
4K1-3-V	R2	14.1	5.87	13.5	3.86	13.0	6.73	6.18	6.73	16.53

Appendix C

EMC Instructions and Maximum Cable Lengths

Mandatory Installation Instruction According to the EMC Directive for type ACS 160 frequency converters

EMC stands for Electromagnetic Compatibility. This is the ability of electrical and electronic equipment to operate without problems within an electromagnetic environment and without disturbing or interfering with nearby equipment.

The EMC Directive defines the requirements for immunity and emissions of electrical equipment used in European Economic Area. The EMC product standard EN 61800-3 covers the requirements stated for frequency converters. Depending on the type of ACS 160 frequency converters the requirements of EN 61800-3 for Second Environment and First Environment, restricted and unrestricted distribution are met. For further information refer to the following pages of this appendix.

Product standard EN 61800-3 (Adjustable speed electrical power drive systems - Part 3: EMC product standard including specific test methods) defines **First Environment** as environment that includes domestic premises. It also includes establishments directly connected without intermediate transformers to a low voltage power supply network which supplies buildings used for domestic purposes.

Second Environment includes establishments other than those directly connected to a low voltage power supply network which supplies buildings used for domestic purposes.

The following section describes the various markings used to verify the correct usage of directives and rules.

CE Marking

A CE mark is attached to ACS 160 frequency converters to verify that the unit follows the provisions of the European Low Voltage and EMC Directives (Directive 73/23/EEC, as amended by 93/68/EEC and Directive 89/336/EEC, as amended by 93/68/EEC).

To ensure compatibility follow the instructions given in this manual and the instructions delivered with different accessories.

Cabling Instructions

Keep individual unscreened wires between the cable clamps and the screw terminals as short as possible. Route control cables away from power cables.

Mains Cable

A four conductor cable (three phase with protective earth) is recommended for the mains cabling. Shielding is not necessary. Dimension the cables and fuses in accordance with the input current. Always pay attention to local legislation when sizing the cables and fuses.

Motor Cable (wall mounting)

The motor cable must be a symmetrical three conductor cable with a concentric PE conductor or a four conductor cable with a concentric shield, however, a symmetrical constructed PE conductor is always recommended. Minimum requirement for the motor cable screen is presented in Figure 32.

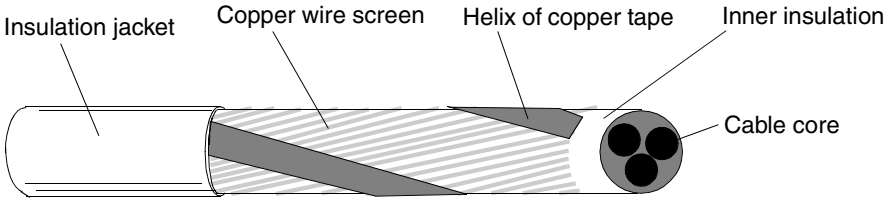

Figure 32 Minimum requirement for motor cable screen (e.g. MCMK, NK Cables).

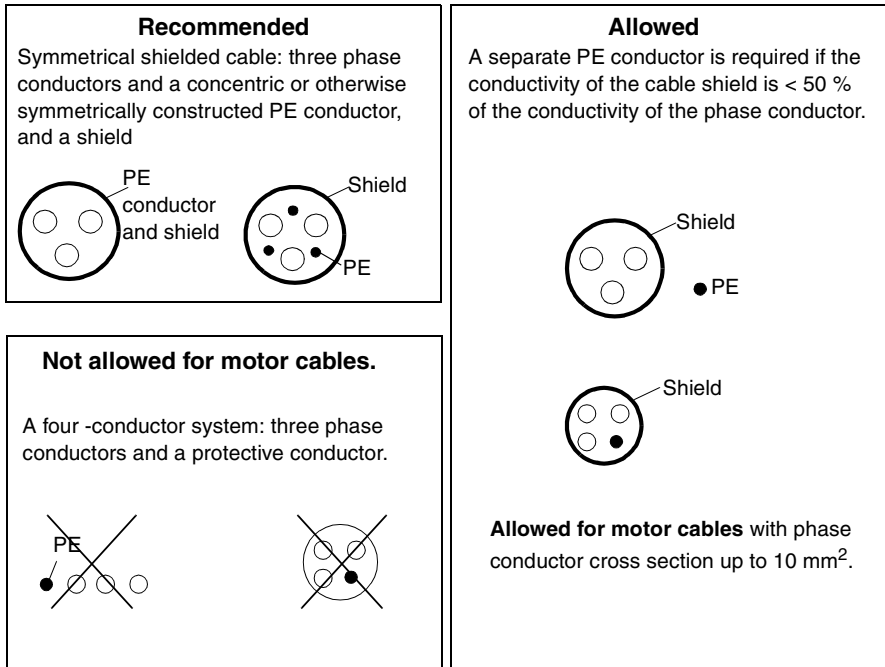

Figure 33 Cable recommendations and restrictions.

The general rule for cable screen effectiveness is: the better and tighter the screen of the cable, the lower the radiated emission level. Example of an effective construction is presented in Figure 34.

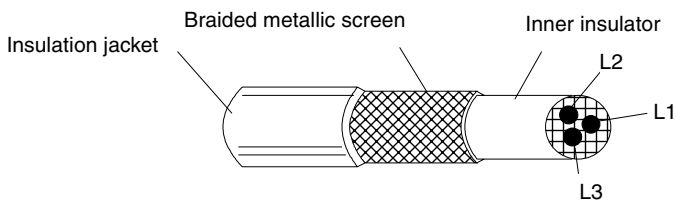

Figure 34 Effective motor cable screen (e.g. Ölflex-Servo-FD 780 CP, Lappkabel or MCCMK, NK Cables).

Clamp the cable shield into the gland plate at the converter end and twist the cable screen wires together into a bundle not longer than five times its width and connect it to the terminal marked \perp , if you are using cable without a separate PE conductor.

At the motor end the motor cable screen must be earthed 360 degrees with an EMC cable gland (e.g. ZEMREX SCG Screened cable glands) or the screen wires must be twisted together into a bundle not longer than five times its width and connected to the PE terminal of the motor.

Control Cables

Control cables must be multi-core cables with a braided copper wire screen.

The screen must be twisted together into a bundle not longer than five times its width and connected to terminal X1:1 (digital and analogue I/O).

Route the control cables as far away as possible from the mains and motor cables (at least 20 cm). Where control cables must cross power cables make sure they are at an angle as near 90 degrees as possible. Also the cable routing must be done so that the distance from the sides of the converter is at least 20 cm to avoid excessive radiation to the cable.

A double shielded twisted pair cable is recommended for the analogue signals. Employ one individually shielded pair for each signal. Do not use common return for different analogue signals.

A double shielded cable is the best alternative for low voltage digital signals but single shielded twisted multipair cable is also usable (see Figure 35).

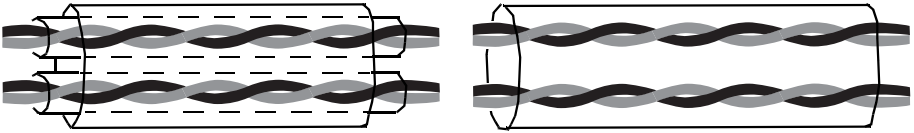

Figure 35 A double shielded twisted pair cable on the left and a single shielded twisted multipair cable on the right.

The analogue and digital input signals should be run in separate, screened cables.

Relay-controlled signals, providing their voltage does not exceed 48 V, can be run in the same cables as digital input signals. It is recommended that the relay-controlled signals be run as twisted pairs.

Never mix 24 VDC and 115/230 VAC signals in the same cable.

Note! When the overriding control equipment and the ACS 160 are installed inside the same cabinet, these recommendations might be overly cautious. If the customer plans to test the entire installation, there is an opportunity to save some costs by relaxing these recommendations, for example by using unshielded cable for the digital inputs. But the customer must verify this.

Control Panel Cable

When mounting control panel far away from the converter use CA-PAN-L

Route the control panel cable as far away as possible from the mains and motor cables (at least 20 cm). Also the cable routing must be done so that the distance from the sides of the converter is at least 20 cm (8 in) to avoid excessive radiation to the cable.

Wall Mounted Units

Compliance with EN61800-3 EMC Standard

Second Environment

Use a converter type which complies with the 2nd environment EMC requirements as specified in Table 10 and follow the instructions for all cable screen connections.

The motor cable lengths have to be limited as specified in Table 10 and must have effective screen according to Figure 34. At the motor end, the cable screen must be earthed 360 degrees with an EMC cable gland (e.g. Zemrex SCG screened cable glands).

Table 10 Maximum motor cable lengths (m / ft) to comply with EN 61800-3 2nd Environment

Wall mounting with EMC filter	Input voltage Switching frequency							
2nd Environment	Restricted Distribution				Unrestricted Distribution			
Type	400 V		480 V		400 V		480 V	
	4 kHz m / ft	8 kHz m / ft	4 kHz m / ft	8 kHz m / ft	4 kHz m / ft	8 kHz m / ft	4 kHz m / ft	8 kHz m / ft
ACS 163-1K1-3-E /-V	40 / 131	20 / 66	20 / 66	10 / 33	40 / 131	20 / 66	20 / 66	10 / 33
ACS 163-1K6-3-E /-V	60 / 197	20 / 66	20 / 66	10 / 33	60 / 197	20 / 66	20 / 66	10 / 33
ACS 163-2K1-3-E /-V	80 / 262	20 / 66	20 / 66	10 / 33	80 / 262	20 / 66	20 / 66	10 / 33
ACS 163-2K7-3-E	90 / 295	50 / 164	40 / 131	30 / 98	90 / 295	50 / 164	40 / 131	30 / 98
ACS 163-4K1-3-E /-V	100 / 328	100 / 328	80 / 262	80 / 262	100 / 328	100 / 328	80 / 262	80 / 262

First Environment

Use a converter type which complies with the 1st environment EMC requirements as specified in Table 11 and follow the instructions for all cable screen connections.

The motor cable lengths have to be limited as specified in Table 11 and must have effective screen according to Figure 34. At the motor end, the cable screen must be earthed 360 degrees with an EMC cable gland (e.g. Zemrex SCG screened cable glands).

Table 11 Maximum cable lengths (m / ft) to comply with EN 61800-3 1st Environment

Wall mounting with EMC filter	Input voltage Switching frequency							
1st Environment	Restricted Distribution				Unrestricted Distribution			
Type	400 V		480 V		400 V		480 V	
	4 kHz m / ft	8 kHz m / ft	4 kHz m / ft	8 kHz m / ft	4 kHz m / ft	8 kHz m / ft	4 kHz m / ft	8 kHz m / ft
ACS 163-1K1-3-E /-V	10 / 33	10 / 33	10 / 33	10 / 33	5 / 16	5 / 16	5 / 16	5 / 16
ACS 163-1K6-3-E /-V	10 / 33	10 / 33	10 / 33	10 / 33	5 / 16	5 / 16	5 / 16	5 / 16
ACS 163-2K1-3-E /-V	10 / 33	10 / 33	10 / 33	10 / 33	5 / 16	5 / 16	5 / 16	5 / 16
ACS 163-2K7-3-E	10 / 33	10 / 33	10 / 33	10 / 33	5 / 16	5 / 16	5 / 16	5 / 16
ACS 163-4K1-3-E /-V	10 / 33	10 / 33	10 / 33	10 / 33	5 / 16	5 / 16	5 / 16	5 / 16

Non-compliance with EN 61800-3 EMC Standard

When EMC requirements do not need to be fulfilled, the maximum motor cable lengths are specified in Table 12 below.

Table 12 Maximum motor cable lengths (m / ft)

Wall mounting without EMC filter	Input voltage Switching frequency			
	400 V		500 V	
	4 kHz m / ft	8kHz m / ft	4kHz m / ft	8kHz m / ft
ACS 163-1K1-3-D / -U	40 / 131	20 / 66	20 / 66	10 / 33
ACS 163-1K6-3-D / -U	60 / 197	40 / 131	20 / 66	10 / 33
ACS 163-2K1-3-D / -U	80 / 262	60 / 197	20 / 66	10 / 33
ACS 163-2K7-3-D	100 / 328	80 / 262	40 / 131	30 / 98
ACS 163-4K1-3-D / -U	100 / 328	100 / 328	80 / 262	80 / 262

Output chokes can be used to increase motor cable length as specified in Table 13. The enclosure rating for output chokes is IP20

Table 13 Maximum motor cable lengths with output chokes (m / ft)

Type	Input choke	output choke ¹⁾	Max motor cable length (m / ft)
ACS 163-1K1-3-D / -U	ACS-CHK-A3	ACS-CHK-B3	60 / 197
ACS 163-1K6-3-D / -U	ACS-CHK-A3	ACS-CHK-B3	80 / 262
ACS 163-2K1-3-D / -U	ACS-CHK-B3	ACS-CHK-B3	100 / 328
ACS 163-2K7-3-D	ACS-CHK-B3	ACS-CHK-C3	120 ²⁾ / 394
ACS 163-4K1-3-D / -U	ACS-CHK-C3	ACS-CHK-C3	140 ²⁾ / 459

1) Supply voltage 380-480, switching frequency 4 kHz.

2) If the supply voltage is higher than or equal to 440 V the maximum cable length is 100 m.

Motor Mounted Units

Compliance with EN61800-3 EMC Standard

Second Environment

ACS 160 types ACS 163-xKx-3-B, -S comply with the requirements of EN 61800-3 Second Environment, Unrestricted and Restricted Distribution, with switching frequency of 4 kHz or 8 kHz, when mounted on the top of the motor.

For EMC information concerning ACS 160 types 163-xKx-3-A, -R please contact your local ABB supplier.

First Environment

ACS 160 types ACS 163-xKx-3-B, -S comply with the requirements of EN 61800-3 First Environment, Unrestricted and Restricted Distribution, with switching frequency of 4 kHz or 8 kHz, when mounted on the top of the motor.

Line Current Harmonics

The product standard EN 61800-3 refers to EN 61000-3-2 which specifies limits for harmonic current emissions for equipment intended to be connected to public low-voltage distribution systems.

Low-Voltage Public Supply Network

The limits and requirements of the EN 61000-3-2 apply for equipment with rated current ≤ 16 A. The ACS 160 is a professional equipment to be used in trades, professions, or industries and is not intended for sale to the general public.

The ACS 160 with a total rated power greater than 1 kW conforms with EN 61000-3-2. Below 1 kW, use the following units to comply with class A limits of EN 61000-3-2: ACS163-1K1-3-B, -S, -E, -V and ACS163-1K6-3-B, -S, -E, -V.

Industrial Networks

If ACS 160 is used in an industrial installation for which the EN 61000-3-2 is not relevant, a reasonable economical approach which considers the total installation shall be used.

Typically a single low power equipment like ACS 160 does not cause a significant voltage distortion to network. However, the user shall be aware of the values of the harmonics currents and voltages occurring within the power supply system before connecting the ACS 160, as well as the internal impedance of the supply system. The current harmonic levels of the ACS 160 under rated load conditions are available on request and the assessment procedure given in appendix B of the EN 61800-3 may be used as guide.

Distribution Networks Isolated from Earth

ACS 160 types 163-xKx-B, S,-E, -V cannot be used in an isolated, or high impedance earthed industrial distribution networks.



ABB Oy
BAU Drives
P.O. Box 184
00381 Helsinki
FINLAND
Telephone +358-10-2211
Telefax +358-10-222 2681

ABB Inc.
Drives & Power Electronics
16250 W. Glendale Drive
New Berlin, WI 53151
USA
Telephone (262) 785-3200
(800) 243-4384
Telefax (262) 780-5135

3BFE 64364120 REV C
EN

Effective: 17. 5. 2002

© 2002 ABB Oy

Subject to change without prior notice.