

Allen-Bradley

SLC 500™ RTD/Resistance Input Module

(Catalog Number 1746-NR8)

User Manual

**Rockwell
Automation**

Important User Information

Because of the variety of uses for the products described in this publication, those responsible for the application and use of this control equipment must satisfy themselves that all necessary steps have been taken to assure that each application and use meets all performance and safety requirements, including any applicable laws, regulations, codes and standards.

The illustrations, charts, sample programs and layout examples shown in this guide are intended solely for purposes of example. Since there are many variables and requirements associated with any particular installation, Allen-Bradley does not assume responsibility or liability (to include intellectual property liability) for actual use based upon the examples shown in this publication.

Allen-Bradley publication SGI-1.1, *Safety Guidelines for the Application, Installation and Maintenance of Solid-State Control* (available from your local Allen-Bradley office), describes some important differences between solid-state equipment and electromechanical devices that should be taken into consideration when applying products such as those described in this publication.

Reproduction of the contents of this copyrighted publication, in whole or part, without written permission of Rockwell Automation, is prohibited.

Throughout this manual we use notes to make you aware of safety considerations:

ATTENTION

Identifies information about practices or circumstances that can lead to personal injury or death, property damage or economic loss

Attention statements help you to:

- identify a hazard
- avoid a hazard
- recognize the consequences

IMPORTANT

Identifies information that is critical for successful application and understanding of the product.

S.L.C. 500 is a trademark of Rockwell Automation.

PLC-5 is a registered trademark of Rockwell Automation.

Belden is a trademark of Belden Inc.

Preface	Who Should Use This Manual	P-1
	Purpose of This Manual	P-1
	Related Documentation	P-2
	Common Techniques Used in this Manual	P-3
	Rockwell Automation Support	P-3
	Local Product Support	P-3
	Technical Product Assistance.	P-3
	Your Questions or Comments on this Manual	P-3
	Chapter 1	
Overview	Description	1-1
	RTD Compatibility	1-3
	Resistance Device Compatibility	1-5
	Hardware Overview	1-5
	General Diagnostic Features	1-6
	System Overview.	1-7
	System Operation	1-7
	Module to Processor Communication.	1-10
	Chapter 2	
Installation and Wiring	Compliance to Europe Union Directives.	2-1
	EMC Directive	2-1
	Safety Considerations	2-2
	Electrostatic Damage.	2-2
	Hazardous Location Considerations	2-2
	Power Requirements	2-3
	Module Location in Chassis	2-4
	Modular Chassis Considerations	2-4
	Fixed Expansion Chassis Considerations	2-4
	General Considerations	2-5
	Module Installation and Removal	2-5
	Removing the Terminal Block.	2-6
	Installing the Module	2-7
	Removing the Module.	2-7
	Terminal Wiring	2-8
	Wiring Considerations	2-8
	Wiring Resistance Devices (Potentiometers) to the Module	2-11
	Wiring Input Devices to the Module.	2-14
	Calibration	2-15
	Factory Calibration	2-15
	Autocalibration	2-15
	Single-Point Calibration	2-16

Preliminary Operating Considerations

Chapter 3

Module ID Code	3-1
Module Addressing	3-2
Output Image - Configuration Words	3-4
Input Image - Data Words and Status Words	3-4
Channel Filter Frequency Selection	3-5
1746-NR8 Channel Step Response	3-5
Effective Resolution	3-6
Channel Cut-Off Frequency	3-7
Channel Autocalibration	3-10
Update Time and Scanning Process	3-10
Input Response	3-12
Output Response	3-12

Channel Configuration, Data, and Status

Chapter 4

Channel Configuration	4-1
Channel Configuration Procedure	4-3
Configure Each Channel	4-3
Enter the Configuration Data	4-4
Input Type Selection (Bits 0 through 3)	4-6
Data Format Selection (Bits 4 and 5)	4-6
Broken Input Selection (Bits 6 and 7)	4-16
Temperature Units Selection (Bit 8)	4-17
Filter Frequency Selection (Bits 9 and 10)	4-17
Channel Enable Selection (Bit 11)	4-17
Excitation Current Selection (Bit 12)	4-18
Calibration Disable (Bit 13)	4-18
Lead Resistance Measurement Enable (Bits 14 and 15)	4-18
Channel Data Word	4-19
Channel Status Checking	4-19
Input Type Status (Bits 0 through 3)	4-22
Data Format Status (Bits 4 and 5)	4-22
Broken Input Status (Bits 6 and 7)	4-22
Temperature Units Status (Bit 8)	4-22
Channel Filter Frequency (Bits 9 and 10)	4-23
Channel Enable Status (Bit 11)	4-23
Calibration Error (Bit 12)	4-23
Broken Input Error (Bit 13)	4-23
Out-Of-Range Error (Bit 14)	4-24
Configuration Error (Bit 15)	4-24

	Chapter 5	
Ladder Programming Examples	Device Configuration	5-1
	Initial Programming	5-2
	Dynamic Programming.	5-4
	Verifying Channel Configuration Changes	5-4
	Interfacing to the PID Instruction.	5-5
	Using the Proportional Counts Data Format with the User-set Scaling (Class 3).	5-7
	Monitoring Channel Status Bits	5-8
	Invoking Autocalibration	5-10
	Chapter 6	
Module Diagnostics and Troubleshooting	Module Operation vs. Channel Operation	6-1
	Power-Up Diagnostics.	6-2
	Channel Diagnostics	6-2
	LED Indicators	6-2
	Error Codes.	6-3
	Channel Status LEDs (Green).	6-4
	Module Status LED (Green).	6-5
	Replacement Parts.	6-7
	Contacting Rockwell Automation	6-7
	Chapter 7	
Application Examples	Basic Example	7-1
	Channel Configuration	7-1
	Program Listing.	7-2
	Supplementary Example	7-3
	Channel Configuration	7-4
	Program Setup and Operation Summary.	7-6
	Program Listing.	7-6
	Appendix A	
Specifications	Electrical Specifications	A-1
	Physical Specifications.	A-1
	Environmental Specifications	A-2
	Input Specifications.	A-2
	Module Accuracy	
	RTD Temperature Ranges, Resolution, and Repeatability	A-3
	RTD Accuracy and Temperature Drift Specifications	A-4
	Resistance Device Compatibility	A-5
	Cable Specifications	A-5
	RTD Standards.	A-5

Configuration Worksheet for RTD/ Resistance Module	Appendix B
	Glossary
	Index

Read this preface to familiarize yourself with the rest of the manual. This preface covers the following topics:

- who should use this manual
- the purpose of this manual
- terms and abbreviations
- conventions used in this manual
- Allen-Bradley support

Who Should Use This Manual

Use this manual if you are responsible for designing, installing, programming, or troubleshooting control systems that use Allen-Bradley small logic controllers.

You should have a basic understanding of SLC 500™ products. You should understand programmable controllers and be able to interpret the ladder logic instructions required to control your application. If you do not, contact your local Allen-Bradley representative for information on available training courses before using this product.

Purpose of This Manual

This manual is a reference guide for the 1746-NR8 RTD/Resistance Input Module. The manual:

- gives you an overview of system operation
- explains the procedures you need to install and wire the module at the customer site
- provides ladder programming examples
- provides an application example of how this input module can be used to control a process

Related Documentation

The following documents contain information that may be helpful to you as you use Allen-Bradley SLC™ products. To obtain a copy of any of the Allen-Bradley documents listed, contact your local Allen-Bradley office or distributor.

For	Read this Document	Document Number
An overview of the SLC 500 family of products	SLC 500 System Overview	1747-S0001A-US-P
A description on how to install and use your Modular SLC 500 programmable controller	Installation and Operation Manual for Modular Hardware Style Programmable Controllers	1747-6.2
A description on how to install and use your Fixed SLC 500 programmable controller	Installation & Operation Manual for Fixed Hardware Style Programmable Controllers	1747-6.21
A reference manual that contains status file data, instruction set, and troubleshooting information about APS	SLC 500 and MicroLogix™ 1000 Instruction Set Reference Manual	1747-6.15
A procedural and reference manual for technical personnel who use an HHT to develop control applications	Allen-Bradley Hand-Held Terminal User's Manual	1747-NP002
An introduction to HHT for first-time users, containing basic concepts but focusing on simple tasks and exercises, and allowing the reader to begin programming in the shortest time possible	Getting Started Guide for HHT	1747-NM009
A resource manual and user's guide containing information about the analog modules used in your SLC 500 system.	SLC 500 Analog I/O Modules User's Manual	1746-6.4
In-depth information on grounding and wiring Allen-Bradley programmable controllers	Allen-Bradley Programmable Controller Grounding and Wiring Guidelines	1770-4.1
A description of important differences between solid-state programmable controller products and hard-wired electromechanical devices	Application Considerations for Solid-State Controls	SGL-1.1
A complete listing of current Allen-Bradley documentation, including ordering instructions. Also indicates whether the documents are available on CD-ROM or in multi-languages.	Allen-Bradley Publication Index	SD499
A glossary of industrial automation terms and abbreviations	Allen-Bradley Industrial Automation Glossary	AG-7.1
An article on wire sizes and types for grounding electrical equipment	National Electrical Code	Published by the National Fire Protection Association of Boston, MA.

Common Techniques Used in this Manual

The following conventions are used throughout this manual:

- Bulleted lists such as this one provide information, not procedural steps.
- Numbered lists provide sequential steps or hierarchical information.
- *Italic* type is used for emphasis.

Rockwell Automation Support

Rockwell Automation offers support services worldwide, with over 75 Sales/Support Offices, 512 authorized Distributors and 260 authorized Systems Integrators located throughout the United States alone, plus Rockwell Automation representatives in every major country in the world.

Local Product Support

Contact your local Rockwell Automation representative for:

- sales and order support
- product technical training
- warranty support
- support service agreements

Technical Product Assistance

If you need to contact Rockwell Automation for technical assistance, please review the information in the *Module Diagnostics and Troubleshooting* chapter first. Then call your local Rockwell Automation representative.

Your Questions or Comments on this Manual

If you have any suggestions for how this manual could be made more useful to you, please contact us at the address below:

Rockwell Automation
Control and Information Group
Technical Communication, Dept. A602V
P.O. Box 2086
Milwaukee, WI 53201-2086

Overview

This chapter describes the 8-channel **1746-NR8 RTD/Resistance Input Module** and explains how the SLC controller gathers RTD (Resistance Temperature Detector) temperature or resistance-initiated analog input from the module. Included is:

- a general description of the module's hardware and software features
- an overview of system operation

For the rest of the manual, the **1746-NR8 RTD/Resistance Input Module** is referred to as simply the **RTD module**.

The RTD module receives and stores digitally converted analog data from RTDs or other resistance inputs such as potentiometers into its image table for retrieval by all fixed and modular SLC 500 processors. An RTD consists of a temperature-sensing element connected by 2, 3, or 4 wires that provide input to the RTD module. The module supports connections from any combination of up to eight RTDs of various types (for example: platinum, nickel, copper, or nickel-iron) or other resistance inputs.

Description

The RTD module supplies a small current to each RTD connected to the module inputs (up to 8 input channels). The module provides on-board scaling and converts RTD input to temperature (°C °F or reports resistance input in ohms).

Each input channel is individually configurable for a specific input device. Broken sensor detection (open- or short-circuit) is provided for each input channel. In addition, the module provides indication if the input signal is out-of-range. For more detail on module functionality, refer to the subsection entitled **System Overview** later in this chapter.

Figure 1.1 Simplified RTD Module Circuit

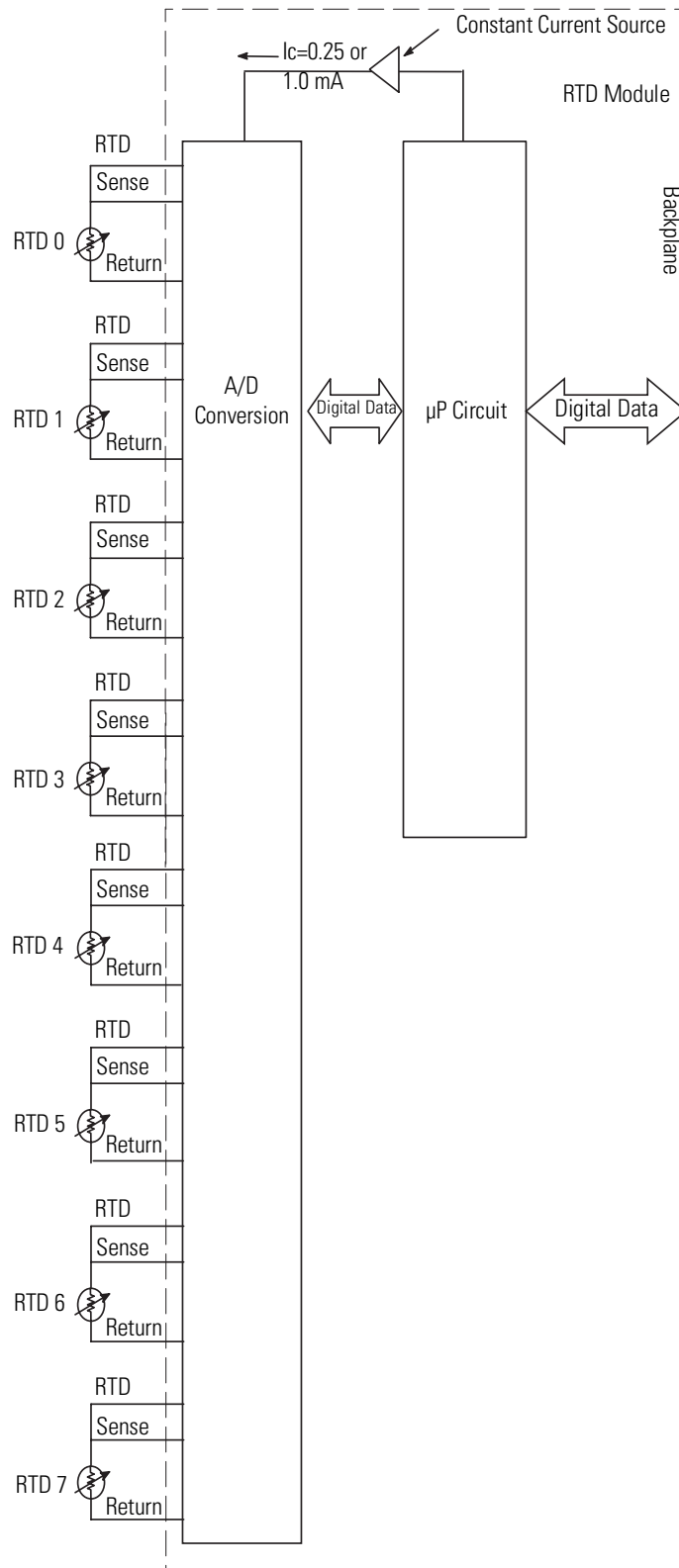

RTD Compatibility

The following table lists the RTD types used with the RTD module and gives each type's associated temperature range, resolution, and repeatability specifications. The next table shows the accuracy and temperature drift specifications for the RTDs.

Table 1.1 RTD Temperature Ranges, Resolution, and Repeatability

Input Type		Temp. Range (0.25 mA Excitation) ⁽¹⁾	Temp. Range (1.0 mA Excitation) ⁽¹⁾	Resolution	Repeatability (28 Hz, 50/60 Hz)
Platinum (385) ⁽²⁾	100Ω	-200°C to +850°C (-328°F to +1562°F)	-200°C to +850°C (-328°F to +1562°F)	0.1°C (0.1°F)	± 0.2°C (± 0.4°F)
	200Ω	-200°C to +850°C (-328°F to +1562°F)	-200°C to +850°C (-328°F to +1562°F)	0.1°C (0.1°F)	± 0.2°C (± 0.4°F)
	500Ω	-200°C to +850°C (-328°F to +1562°F)	-200°C to +390°C (-328°F to +698°F)	0.1°C (0.1°F)	± 0.2°C (± 0.4°F)
	1000Ω	-200°C to +850°C (-328°F to +1562°F)	-200°C to +50°C (-328°F to +122°F)	0.1°C (0.1°F)	± 0.2°C (± 0.4°F)
Platinum (3916) ⁽²⁾	100Ω	-200°C to +630°C (-328°F to +1166°F)	-200°C to +630°C (-328°F to +1166°F)	0.1°C (0.1°F)	± 0.2°C (± 0.4°F)
	200Ω	-200°C to +630°C (-328°F to +1166°F)	-200°C to +630°C (-328°F to +1166°F)	0.1°C (0.1°F)	± 0.2°C (± 0.4°F)
	500Ω	-200°C to +630°C (-328°F to +1166°F)	-200°C to +380°C (-328°F to +698°F)	0.1°C (0.1°F)	± 0.2°C (± 0.4°F)
	1000Ω	-200°C to +630°C (-328°F to +1166°F)	-200°C to +50°C (-328°F to +122°F)	0.1°C (0.1°F)	± 0.2°C (± 0.4°F)
Copper (426) ^{(2) (3)}	10Ω	-100°C to +260°C (-328°F to +500°F)	-100°C to +260°C (-328°F to +500°F)	0.1°C (0.1°F)	± 0.2°C (± 0.4°F)
Nickel (618) ^{(2) (4)}	120Ω	-100°C to +260°C (-328°F to +500°F)	-100°C to +260°C (-328°F to +500°F)	0.1°C (0.1°F)	± 0.1°C (± 0.2°F)
Nickel (672) ⁽²⁾	120Ω	-80°C to +260°C (-328°F to +500°F)	-80°C to +260°C (-328°F to +500°F)	0.1°C (0.1°F)	± 0.1°C (± 0.2°F)
Nickel Iron (518) ⁽²⁾	604Ω	-200°C to +200°C (-328°F to +392°F)	-200°C to +180°C (-328°F to +338°F)	0.1°C (0.1°F)	± 0.1°C (± 0.2°F)

(1) The temperature range for the 1000Ω, 500Ω, and 604Ω RTD is dependent on the excitation current.

(2) The digits following the RTD type represent the temperature coefficient of resistance (α), which is defined as the resistance change per ohm per °C. For instance, Platinum 385 refers to a platinum RTD with $\alpha = 0.00385$ ohms/ohm · °C or simply 0.00385 /°C.

(3) Actual value at 0°C is 9.042Ω per SAMA standard RC21-4-1966.

(4) Actual value at 0°C is 100Ω per DIN standard.

IMPORTANT

The exact signal range valid for each input type is dependent upon the excitation current magnitude that you select when configuring the module. For details on excitation current, refer to Appendix A.

Table 1.2 RTD Accuracy and Temperature Drift Specifications

Input Type		0.25 mA Excitation		1.0 mA Excitation	
		Accuracy	Temperature Drift	Accuracy	Temperature Drift
Platinum (385)	100Ω	±0.5°C (±0.9°F)	±0.012°C/°C (±0.012°F/°F)	±0.7°C (±1.3°F)	±0.020°C/°C (±0.020°F/°F)
	200Ω	±0.6°C (±1.1°F)	±0.015°C/°C (±0.015°F/°F)	±0.7°C (±1.3°F)	±0.020°C/°C (±0.020°F/°F)
	500Ω	±0.7°C (±1.3°F)	±0.020°C/°C (±0.020°F/°F)	±0.5°C (±0.9°F)	±0.012°C/°C (±0.012°F/°F)
	1000Ω	±1.2°C (±2.2°F)	±0.035°C/°C (±0.035°F/°F)	±0.4°C (±0.7°F)	±0.010°C/°C (±0.010°F/°F)
Platinum (3916)	10 Ω	±0.4°C (±0.7°F)	±0.010°C/°C (±0.010°F/°F)	±0.6°C (±1.1°F)	±0.015°C/°C (±0.015°F/°F)
	200Ω	±0.5°C (±0.9°F)	±0.011°C/°C (±0.011°F/°F)	±0.6°C (±1.1°F)	±0.015°C/°C (±0.015°F/°F)
	500Ω	±0.6°C (±1.1°F)	±0.015°C/°C (±0.015°F/°F)	±0.4°C (±0.7°F)	±0.012°C/°C (±0.012°F/°F)
	1000Ω	±0.9°C (±1.6°F)	±0.026°C/°C (±0.026°F/°F)	±0.3°C (±0.6°F)	±0.010°C/°C (±0.010°F/°F)
Copper (426)	10Ω	±0.5°C (±0.9°F)	±0.008°C/°C (±0.008°F/°F)	±0.8°C (±1.4°F)	±0.008°C/°C (±0.008°F/°F)
Nickel (618)	120Ω	±0.2°C (±0.4°F)	±0.003°C/°C (±0.003°F/°F)	±0.2°C (±0.4°F)	±0.005°C/°C (±0.005°F/°F)
Nickel (672)	120Ω	±0.2°C (±0.4°F)	±0.003°C/°C (±0.003°F/°F)	±0.2°C (±0.4°F)	±0.005°C/°C (±0.005°F/°F)
Nickel Iron (518)	604Ω	±0.3°C (±0.5°F)	±0.008°C/°C (±0.008°F/°F)	±0.3°C (±0.5°F)	±0.008°C/°C (±0.008°F/°F)
Resistance	150Ω	±0.2Ω	±0.004Ω/°C (±0.002Ω/°F)	±0.15Ω	±0.003Ω/°C (±0.002Ω/°F)
	500Ω	±0.5Ω	±0.012Ω/°C (±0.007Ω/°F)	±0.5Ω	±0.012Ω/°C (±0.007Ω/°F)
	1000Ω	±1.0Ω	±0.025Ω/°C (±0.014Ω/°F)	±1.0Ω	±0.025Ω/°C (±0.014Ω/°F)
	3000Ω	±1.5Ω	±0.040Ω/°C (±0.023Ω/°F)	±1.2Ω	±0.040Ω/°C (±0.023Ω/°F)

Resistance Device Compatibility

The table below lists the resistance input types you can use with the RTD module and gives each type's associated specifications.

Table 1.3 Resistance Input Specifications

Input Type		Resistance Range (0.25 mA Excitation)	Resistance Range (1.0 mA Excitation)	Accuracy ⁽¹⁾	Temperature Drift	Resolution	Repeatability
Resistance	150Ω	0Ω to 150Ω	0Ω to 150Ω	(2)	±0.004Ω/°C (±0.002Ω/°F) ⁽³⁾	0.01Ω	0.04Ω
	500Ω	0Ω to 500Ω	0Ω to 500Ω	0.5Ω	±0.012Ω/°C (±0.007Ω/°F)	0.1Ω	0.2Ω
	1000Ω	0Ω to 1000Ω	0Ω to 1000Ω	1.0Ω	0.025Ω/°C (0.014Ω/°F)	0.1Ω	0.2Ω
	3000Ω	0Ω to 3000Ω	0Ω to 1200Ω	1.5Ω	0.040Ω/°C (0.023Ω/°F)	0.1Ω	0.2Ω

(1) The accuracy values assume that the module was calibrated within the specified temperature range of 0°C to 60°C (32°F to 140°F).

(2) The accuracy for 150Ω is dependent on the excitation current: 0.2Ω at 0.25 mA and 0.15Ω at 1.0 mA

(3) The temperature drift for 150Ω is dependent on the excitation current: 0.006Ω/°C at 0.25 mA and 0.004Ω at 1.0 mA

Hardware Overview

The RTD module occupies one slot in an SLC 500:

- modular system, except the processor slot (0)
- fixed system expansion chassis (1746-A2)

The module uses eight input words and eight output words for Class 1 and 16 input words and 24 output words for Class 3.

IMPORTANT

If the RTD module resides in a remote configuration with a SLC 500 Remote I/O Adapter Module (1747-ASB), use block transfer for configuration and data retrieval. Block transfer requires a 1747-SN Remote I/O Scanner (Series B) or PLC[®] processor.

As shown in the illustration below and table that follows, the module contains a removable terminal block (item 3) providing connection for any mix of eight RTD sensors or resistance input devices. There are no output channels on the module. Module configuration is done via the user program. There are no DIP switches.

Figure 1.2 RTD Module Hardware

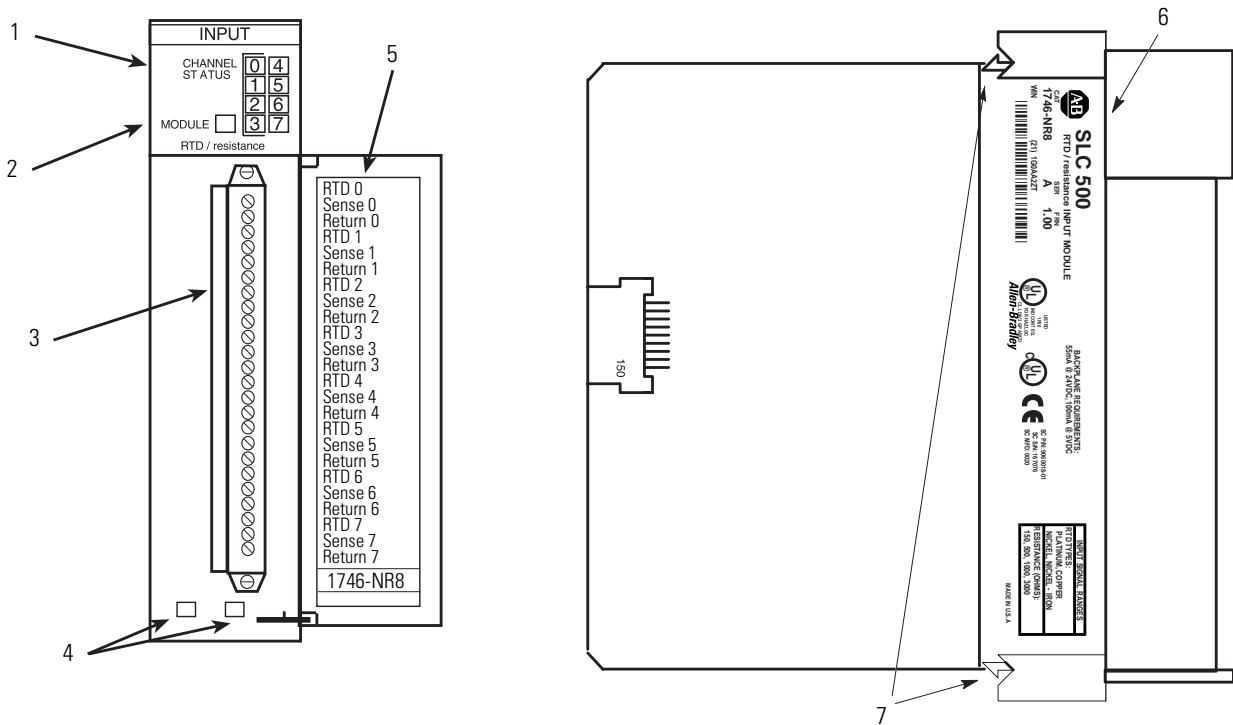

Table 1.4 Hardware Features

Item	Description	Function
1	Channel Status LED Indicators (green)	Displays operating and fault status of channels 0, 1, 2, 3, 4, 5, 6, and 7
2	Module Status LED (green)	Displays module operating and fault status
3	Removable Terminal Block	Provides physical connection to input devices (Catalog # 1746-RT35)
4	Cable Tie Slots	Secures wiring from module
5	Door Label	Provides terminal identification
6	Side Label (Nameplate)	Provides module information
7	Self-Locking Tabs	Secures module in chassis slot

General Diagnostic Features

The RTD module contains diagnostic features that can be used to help you identify the source of problems that may occur during power up or during normal channel operation. These power-up and channel diagnostics are explained in Chapter 6, *Module Diagnostics and Troubleshooting*.

The RTD module communicates to the SLC 500 processor through the parallel backplane interface and receives +5V dc and +24V dc power from the SLC 500 power supply through the backplane. No external power supply is required. You may install as many RTD modules in your system as the power supply can support, as shown in the illustration below.

System Overview

Figure 1.3 RTD Configuration

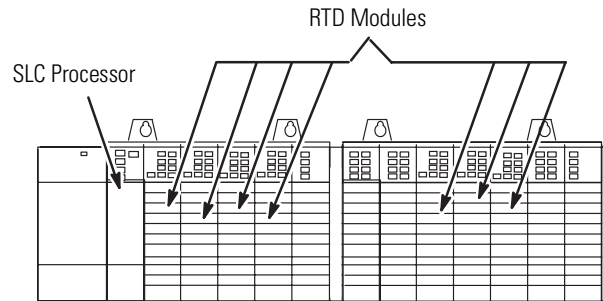

Each individual channel on the RTD module can receive input signals from 2, 3 or 4-wire RTD sensors or from resistance input devices. You configure each channel to accept either input. When configured for RTD input types, the module converts the RTD readings into linearized, digital temperature readings in °C or °F. When configured for resistance inputs, the module provides a linear resistance value in ohms.

IMPORTANT

The RTD module is designed to accept input from RTD sensors with up to 3 wires. When using 4-wire RTD sensors, one of the 2 lead compensation wires is not used and the 4-wire sensor is treated like a 3-wire sensor. Lead wire compensation is provided via the third wire. Refer to Wiring Considerations on page 2-8 for more information.

System Operation

The RTD module has 3 operational states:

- power-up
- module operation
- error (module error and channel error)

Power-up

At power-up, the RTD module checks its internal circuits, memory, and basic functions via hardware and software diagnostics. During this time, the module status LED remains off, and the channel status LEDs are turned on. If no faults are found during the power-up diagnostics, the module status LED is turned on, and the channel status LEDs are turned off.

After power-up checks are complete, the RTD module waits for valid channel configuration data from your SLC ladder logic program (channel status LEDs off). After configuration data is written to one or more channel configuration words and their channel enable bits are set by the user program, the channel status LEDs go on and the module continuously converts the RTD or resistance input to a value within the range you selected for the enabled channels. The module is now operating in its normal state.

Each time a channel is read by the module, that data value is tested by the module for a fault condition, for example, open-circuit, short-circuit, over-range, and under range. If such a condition is detected, a unique bit is set in the channel status word and the channel status LED flashes, indicating a channel error condition.

The SLC processor reads the converted RTD or resistance data from the module at the end of the program scan or when commanded by the ladder program. The processor and RTD module determine that the backplane data transfer was made without error and the data is used in your ladder program.

Module Operation

Each input channel consists of an RTD connection, which provides:

- excitation current
- a sense connection, which detects lead-wire resistance
- a return connection, which reads the RTD or resistance value

Each of these analog inputs are multiplexed to an analog converter.

The A/D converter cycles between reading the RTD or resistance value, the lead wire resistance, and the excitation current. From these readings, an accurate temperature or resistance is returned to the user program.

The RTD module is isolated from the chassis backplane and chassis ground. The isolation is limited to 500V ac. Optocouplers are used to communicate across the isolation barrier. Channel-to-channel common-mode isolation is limited to ± 5 volts.

LED Status

The illustration below shows the RTD module LED panel consisting of nine LEDs. The state of the LEDs (for example, off, on, or flashing) depends on the operational state of the module (see table on page 1-9).

Figure 1.4 LED Indicators

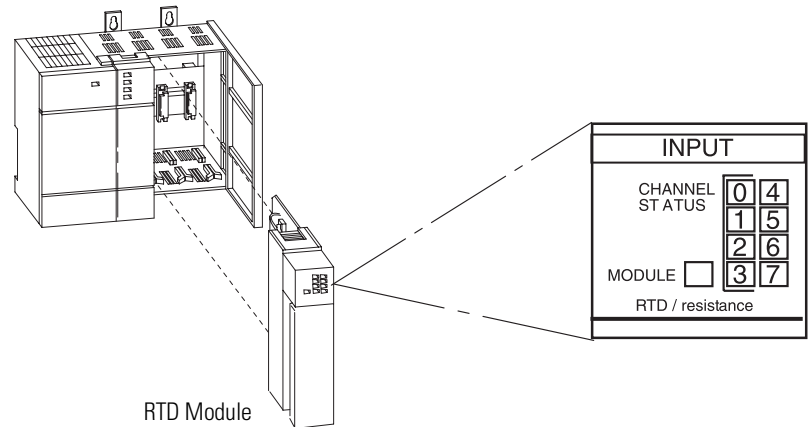

The purpose of the LEDs is as follows:

- Channel Status - One LED for each of the 8 input channels indicates if the channel is enabled, disabled, or is not operating as configured, due to an error.
- Module Status - If OFF or flashing at any time, other than at powerup, this LED indicates that non-recoverable module errors (for example, diagnostic or operating errors) have occurred. The LED is ON if there are no module errors.

The status of each LED, during each of the operational states (for example, powerup, module operation and error), is depicted in the following table.

LED	Power-up ⁽¹⁾	Module Operation (No Error) ⁽²⁾	Module Error	Channel Error
Ch 0 to 7 Status	On	On/Off	Off ⁽³⁾	Flashes
Mod. Status	Off	On	Flashes/Off	On

(1) Module is disabled during powerup.

(2) Channel status LED is On if the respective channel is enabled and Off if the channel is disabled.

(3) Error if channel is enabled.

Module to Processor Communication

As shown in the following illustration, the RTD module communicates with the SLC processor through the backplane of the chassis. The RTD module transfers data to/receives data from the processor by means of an image table. The image table consists of eight input words and eight output words when configured for Class 1 operation; 16 input words and 24 output words when configured for Class 3 operation. Data transmitted from the module to the processor is called the *input image* (for example, Channel Data Words and Channel Status Words). Conversely, data transmitted from the processor to the module is called the *output image* (for example, Channel Configuration Words and Scaling Limit Words). Details about the input and output images are found in “Module Addressing” on page 3-2.

Figure 1.5 Communication Flow

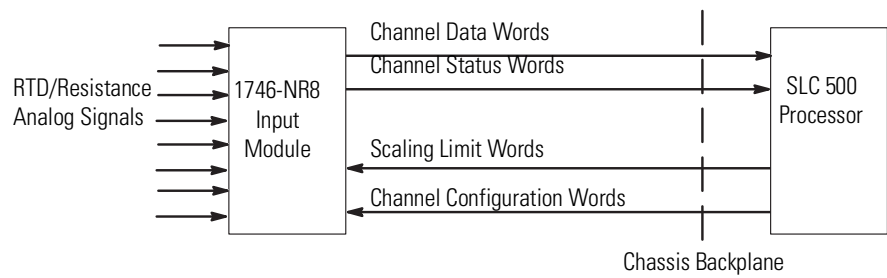

The Channel Configuration Words (output image) contain user-defined configuration information for the specified input channel. This information is used by the module to configure and operate each channel. The Channel Status Words (input image) contain status information about the channel’s current configuration and operational state. The input data values of the analog input channel are contained in the Channel Data Word (input image), which is valid only when the channel is enabled and there are no channel errors (for example, broken sensor or overrange.)

The user-set Scaling Limit Words (output image) provide a user-definable scaling range for the temperature resistance data when using the proportional counts data type.

Installation and Wiring

This chapter tells you how to:

- comply to European union directives
- avoid electrostatic damage
- determine the RTD module's chassis power requirement
- choose a location for the RTD module in the SLC chassis
- install the RTD module
- wire the RTD module's terminal block

This product is approved for installation within the European Union and EEA regions. It has been designed and tested to meet the following directives.

Compliance to Europe Union Directives

EMC Directive

This product is tested to meet Council Directive 89/336/EEC Electromagnetic Compatibility (EMC) and the following standards, in whole or in part, documented in a technical construction file:

- EN 50081-2
EMC - Generic Emission Standard, Part 2 - Industrial Environment
- EN 50082-2
EMC - Generic Immunity Standard, Part 2 - Industrial Environment

This product is intended for use in an industrial environment.

Safety Considerations

Electrostatic Damage

Electrostatic discharge can damage semiconductor devices inside this module if you touch backplane connector pins or other sensitive areas. Guard against electrostatic damage by observing the precautions listed next.

ATTENTION

Electrostatic discharge can degrade performance or cause permanent damage. Handle the module as stated below.

- Wear an approved wrist strap grounding device when handling the module.
 - Touch a grounded object to rid yourself of electrostatic charge before handling the module.
 - Handle the module from the front, away from the backplane connector. Do not touch backplane connector pins.
 - Keep the module in its static-shield bag when not in use, or during shipment.
-

Hazardous Location Considerations

This equipment is suitable for use in Class I, Division 2, Groups A, B, C, D or non-hazardous locations only. The following WARNING statement applies to use in hazardous locations.

EXPLOSION HAZARD

- Substitution of components may impair suitability for Class I, Division 2.
 - Do not replace components or disconnect equipment unless power has been switched off.
 - Do not connect or disconnect components unless power has been switched off.
 - All wiring must comply with N.E.C. article 501-4(b).
-

Power Requirements

The RTD module receives its power through the SLC500 chassis backplane from the fixed or modular +5V dc/+24V dc chassis power supply. The maximum current drawn by the module is shown in the table below.

5V dc	24V dc
0.100A	0.055A

When you are using a *modular system* configuration, add the values shown in the table above to the requirements of all other modules in the SLC chassis to prevent overloading the chassis power supply.

When you are using a *fixed system* controller, refer to the *Important* note about module compatibility in a 2-slot expansion chassis on page 2-4.

Module Location in Chassis

Fixed Controller Compatibility Table

	NR8	5V dc	24V dc
IA4	•	0.035	-
IA8	•	0.050	-
IA16	•	0.085	-
IM4	•	0.035	-
IM8	•	0.050	-
IM16	•	0.085	-
OA8	•	0.185	-
OA16		0.370	-
OAP12		0.370	-
IB8	•	0.050	-
IB16	•	0.085	-
IB32	•	0.050	-
ITB16	•	0.085	-
IV8	•	0.050	-
IV16	•	0.085	-
IV32	•	0.085	-
ITV16	•	0.085	-
IC16	•	0.085	-
IG16	•	0.140	-
IH16	•	0.085	-
OB8	•	0.135	-
OB16	•	0.280	-
OB32 Series D or later	•	0.190	-
OB16E	•	0.135	-
OBP8	•	0.135	-
OBP16	•	0.250	-
OG16	•	0.180	-
OVP16	•	0.250	-
OV8	•	0.135	-
OV16	•	0.270	-
OV32 Series D or later	•	0.190	-
IN16	•	0.085	-
OW4	•	0.045	0.045
OW8	•	0.085	0.090
OW16		0.170	0.180
OX8	•	0.085	0.090
IO4	•	0.030	0.025
IO8	•	0.060	0.045
IO12	•	0.090	0.070
NI4	•	0.025	0.085
NI8		0.200	0.100
NI16I	•	0.125	0.075
NI16V	•	0.125	0.075
NIO4I		0.055	0.145
NIO4V	•	0.055	0.115
FIO4I	•	0.055	0.150
FIO4V	•	0.055	0.120
NO4I		0.055	0.195
NO4V		0.055	0.195
NT4	•	0.060	0.040
NT8	•	0.120	0.070
INT4	•	0.110	0.085
NR4	•	0.050	0.050
HSCE	•	0.320	-
HSCE2	•	0.250	-
BAS	•	0.150	0.040
BASn	•	0.150	0.125
KE	•	0.150	0.040
KEn	•	0.150	0.145
HS	•	0.300	-
HSTP1	•	0.200	-

Modular Chassis Considerations

Place your RTD module in any slot of an SLC 500 modular chassis (except slot 0) or a modular expansion chassis. Slot 0 is reserved for the modular processor or adapter modules.

Fixed Expansion Chassis Considerations

IMPORTANT

The 2-slot, SLC 500 fixed I/O expansion chassis (1746-A2) supports only specific combinations of modules. If you are using the RTD module in a 2-slot expansion chassis with another SLC I/O or communication module, refer to the table at the left to determine whether the combination can be supported.

IMPORTANT

When using the table, be aware that there are certain conditions that affect the compatibility characteristics of the BASIC module (BAS) and the DH-485/RS-232C module (KE).

When you use the BAS module or the KE module to supply power to a 1747-AIC Link Coupler, the link coupler draws its power through the module. The higher current drawn by the AIC at 24V dc is calculated and recorded in the table for the modules identified as BASn (BAS networked) or KEn (KE networked). Make sure to refer to these modules if your application uses the BAS or KE module in this way.

General Considerations

Most applications require installation in an industrial enclosure to reduce the effects of electrical interference. RTD inputs are susceptible to electrical noises due to the small amplitudes of their signal.

Group your modules to minimize adverse effects from radiated electrical noise and heat. Consider the following conditions when selecting a slot for the RTD module. Position the module in a slot:

- away from power lines, load lines and other sources of electrical noise such as hard-contact switches, relays, and AC motor drives
- away from modules which generate significant radiated heat, such as the 32-point I/O modules

Module Installation and Removal

When installing the module in a chassis, it is not necessary to remove the terminal block from the module. However, if the terminal block is removed, use the write-on label located on the side of the terminal block, as shown below, to identify the module location and type.

SLOT ____	RACK ____
● MODULE _____	

Removing the Terminal Block

ATTENTION



Never install, remove, or wire modules with power applied to the chassis or devices wired to the module. To avoid cracking the removable terminal block, alternate the removal of the slotted terminal block release screws.

1. Loosen the two terminal block release screws.

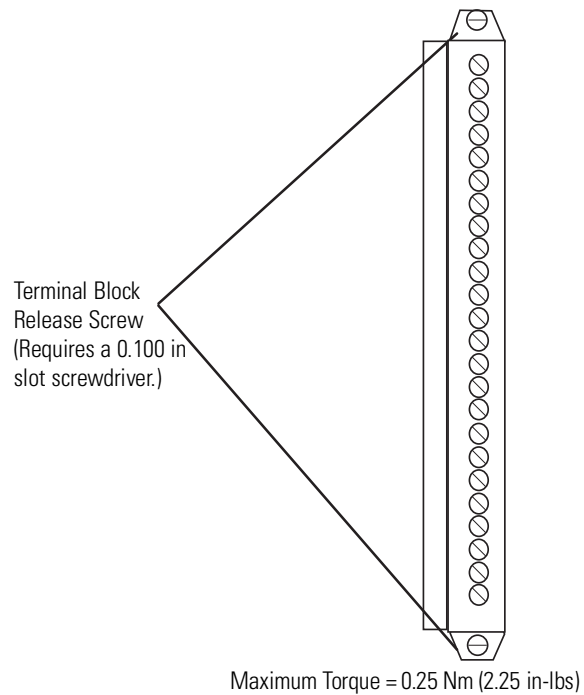

2. Grasp the terminal block at the top and bottom and pull outward and down.

Installing the Module

1. Align the circuit board of the RTD module with the card guides located at the top and bottom of the chassis, as shown in the following illustration.

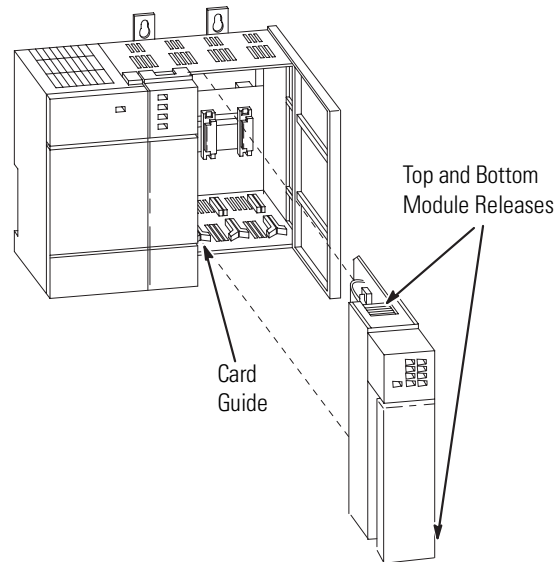

2. Slide the module into the chassis until both top and bottom retaining clips are secured. Apply firm even pressure on the module to attach it to its backplane connector. Never force the module into the slot.
3. Cover all unused slots with the Card Slot Filler, Catalog Number 1746-N2.

Removing the Module

1. Press the releases at the top and bottom of the module and slide the module out of the chassis slot.
2. Cover all unused slots with the Card Slot Filler, Catalog Number 1746-N2.

The RTD module contains an 24-position, removable terminal block. The terminal pin-out is shown in the illustration on page 2-8.

Terminal Wiring

ATTENTION



Disconnect power to the SLC before attempting to install, remove, or wire the removable terminal wiring block. To avoid cracking the removable terminal block, alternate the removal of the terminal block release screws.

Figure 2.1 Terminal Block

(Terminal Block Spare Part Number 1746-RT35)

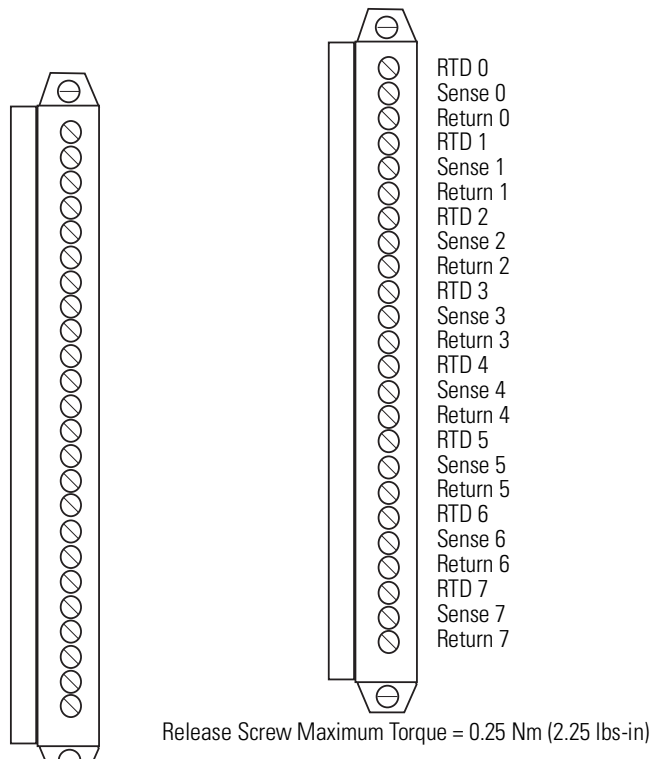

Wiring Considerations

Follow the guidelines below when planning your system wiring.

Since the operating principle of the RTD module is based on the measurement of resistance, take special care in selecting your input cable. For 2-wire or 3-wire configuration, select a cable that has a consistent impedance throughout its entire length.

Configuration	Recommended Cable
2-wire	Belden™ #9501 or equivalent
3-wire less than 30.48m (100 ft.)	Belden #9533 or equivalent
3-wire greater than 30.48m (100 ft.) or high humidity conditions	Belden #83503 or equivalent

For a 3-wire configuration, the module can compensate for a maximum cable length associated with an overall cable impedance of 25 ohms.

IMPORTANT

Details of cable specifications are shown on page A-5.

Three configurations of RTDs can be connected to the RTD module, namely:

- 2-wire RTD, which is composed of 2 RTD lead wires (RTD and Return)
- 3-wire RTD, which is composed of a Sense and 2 RTD lead wires (RTD and Return)
- 4-wire RTD, which is composed of 2 Sense and 2 RTD lead wires (RTD and Return). The second sense wire of a 4-wire RTD is left open. It does not matter which sense wire is left open.

IMPORTANT

The RTD module requires three wires to compensate for lead resistance error. We recommend that you do not use 2-wire RTDs if long cable runs are required, as it reduces the accuracy of the system. However, if a 2-wire configuration is required, reduce the effect of the lead wire resistance by using a lower gauge wire for the cable (for example, use AWG #16 instead of AWG #24). Also, use cable that has a lower resistance per foot of wire. The module's terminal block accepts one AWG #14 gauge wire.

Observe the following wiring guidelines:

- To limit overall cable impedance, keep input cables as short as possible. Locate your I/O chassis as near the RTD sensors as your application permits.
- Ground the shield drain wire at one end only. The preferred location is at the chassis mounting tab of the rack, under the RTD module. Refer to IEEE Std. 518, Section 6.4.2.7 or contact your sensor manufacturer for additional details.
- Route RTD/resistance input wiring away from any high-voltage I/O wiring, power lines, and load lines.
- Tighten terminal screws using a flat-head screwdriver. Each screw should be turned tight enough to immobilize the wire's end. Excessive tightening can strip the terminal screw. The torque applied to each screw should not exceed 0.25 Nm (2.25 in-lbs) for each terminal.
- Follow system grounding and wiring guidelines found in your *SLC 500 Installation and Operation Manual*, publication 1747-6.2.

Figure 2.2 RTD Connections to Terminal Block

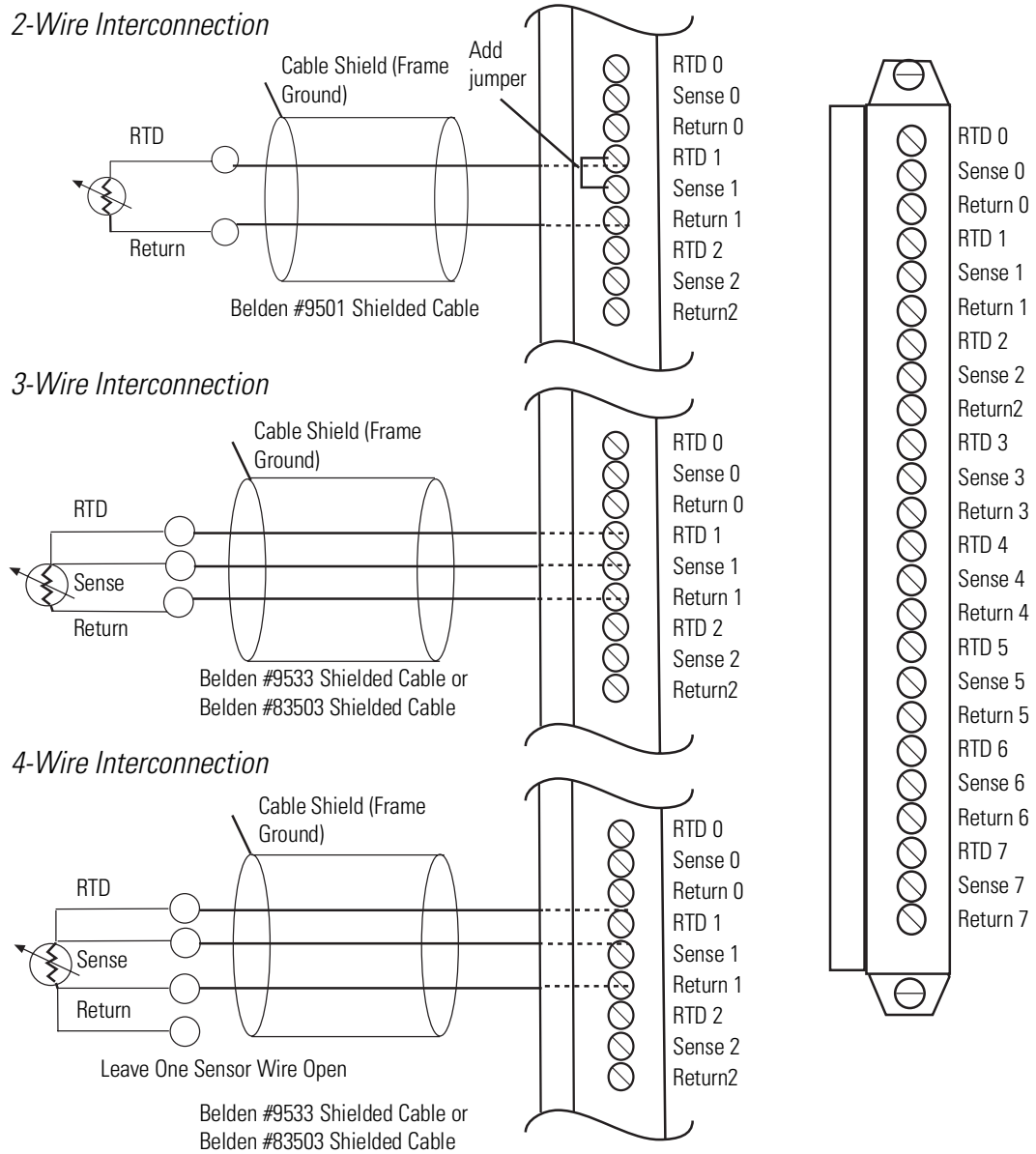

When using a 3-wire configuration, the module compensates for resistance error due to lead wire length. For example, in a 3-wire configuration, the module reads the resistance due to the length of one of the wires and assumes that the resistance of the other wire is equal. If the resistances of the individual lead wires are much different, an error may exist. The closer the resistance values are to each other, the greater the amount of error that is eliminated.

IMPORTANT

To ensure temperature or resistance value accuracy, the resistance difference of the cable lead wires must be equal to or less than 0.01Ω .

There are several ways to insure that the lead values match as closely as possible. They are as follows:

- Keep lead resistance as small as possible and less than 25Ω
- Use quality cable that has a small tolerance impedance rating.
- Use a heavy-gauge lead wire which has less resistance per foot.

Wiring Resistance Devices (Potentiometers) to the Module

Potentiometer wiring requires the same type of cable as that for the RTD described in the previous subsection. Potentiometers can be connected to the RTD module as a 2-wire connection or a 3-wire connection.

Figure 2.32-Wire Potentiometer Connections to Terminal Block

For details on wiring a potentiometer to the module, see page 2-8.

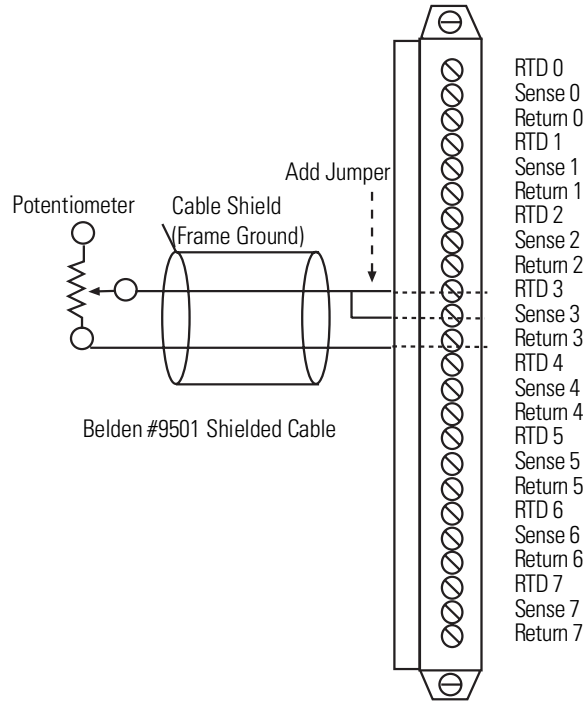

Potentiometer wiper arm can be connected to either the RTD or return terminal depending on whether the user wants increasing or decreasing resistance.

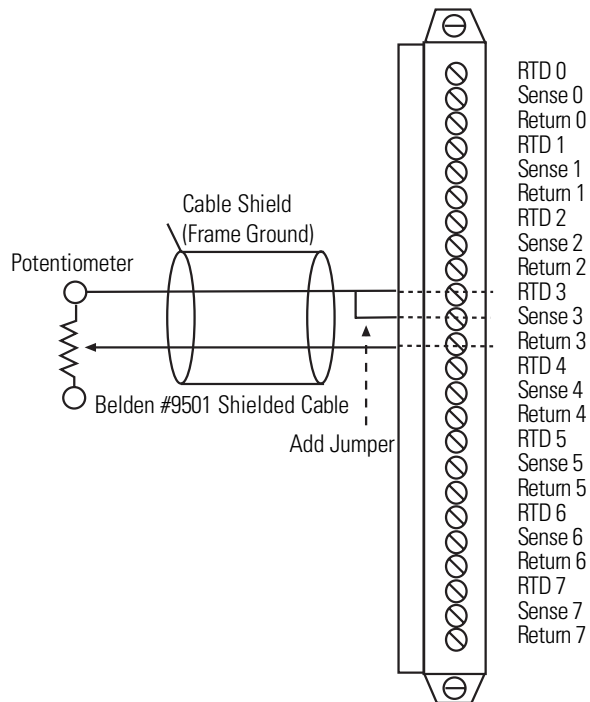
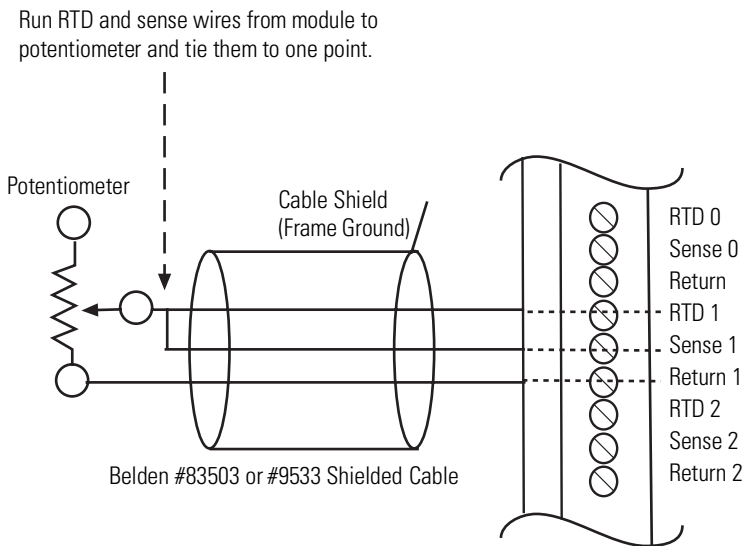
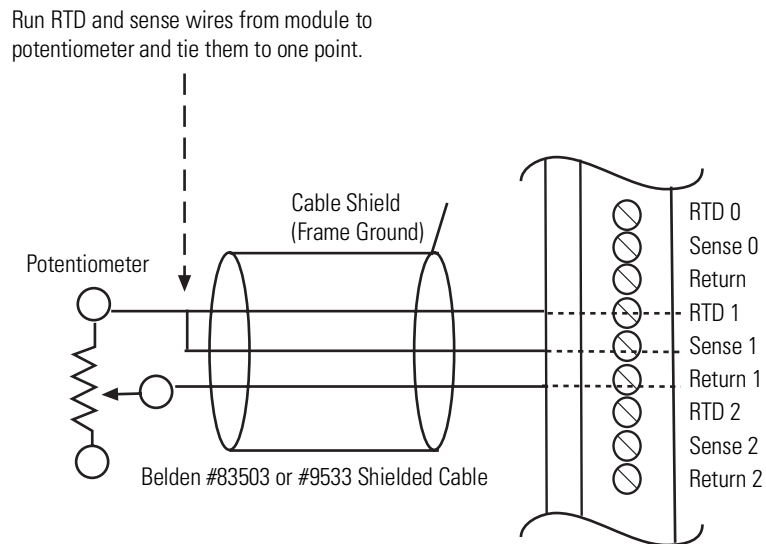

Figure 2.43-Wire Potentiometer Connections to Terminal Block

For details on wiring a potentiometer to the module, see page 2-8.



Potentiometer wiper arm can be connected to either the RTD or return terminal depending on whether the user wants increasing or decreasing resistance.



Wiring Input Devices to the Module

To wire your 1746-NR8 module, follow these steps as shown in the illustration below:

1. At each end of the cable, strip some casing to expose the individual wires.
2. Trim the signal wires to 5.08-cm (2-inch) lengths. Strip about 4.76 mm (3/16 inch) of insulation away to expose the end of the wire.
3. At one end of the cable twist the drain wire and foil shield together, bend them away from the cable, and apply shrink wrap. Then earth ground at the frame ground of the rack.
4. At the other end of the cable, cut the drain wire and foil shield back to the cable and apply shrink wrap.
5. Connect the signal wires to the 1746-NR8 terminal block and the input.
6. Repeat steps 1 through 5 for each channel on the 1746-NR8 module.

Figure 2.5 Shielded Cable

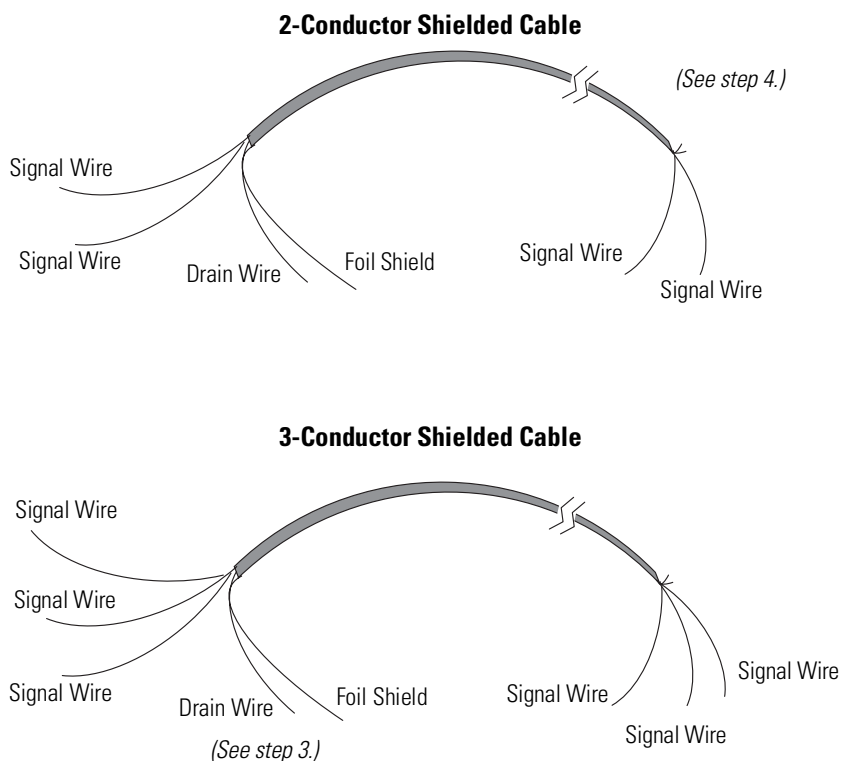

Calibration

The accuracy of a system that uses the RTD module is determined by the following:

- the accuracy of the RTD
- resistance mismatch of the cable wires that connect the RTD to the module
- the accuracy of the RTD module

For optimal performance at the customer site, the RTD module is calibrated at the factory prior to shipment. In addition, an autocalibration feature further ensures that the module performs to specification over the life of the product.

Factory Calibration

The 2-pin calibration connector, on the RTD module circuit board, is used for factory setup only.

Autocalibration

When a channel becomes enabled, the module configures the channel and performs an autocalibration on the module if the combination of input type and excitation current are unique to that channel. Autocalibration performs A/D conversions on the zero voltage and the full-scale voltage of the A/D converter.

IMPORTANT

Channel calibration time is shown in “Channel Autocalibration” on page 3-10.

These conversions generate offset (zero reference) and full scale (span reference) coefficients that are saved and used by the module to perform future A/D conversions.

You can command your module to perform an autocalibration cycle once every 5 minutes by setting any channel's calibration disable bit to 0. To disable autocalibration, all channel's calibration disable bits must be set to 1. You can control the module's autocalibration time by disabling autocalibration, and then setting any channel's calibration disable bit to 0, waiting at least one module scan time and then resetting that channel's calibration disable bit to 1. Several scan cycles are required to perform an autocalibration (see page 3-10). It is important to remember that during autocalibration the module is not converting input data.

TIP

To maintain system accuracy we recommend that you periodically perform an autocalibration cycle, for example:

- whenever an event occurs that greatly changes the internal temperature of the control cabinet, such as opening or closing its door
- at a convenient time when the system is not making product, such as during a shift change

An autocalibration programming example is provided on page 5-10.

Single-Point Calibration

Single-point calibration is an optional procedure that can be used to improve the accuracy of the RTD module and cable combination to greater than $\pm 0.2^{\circ}\text{C}$ (when the RTD is operating at $\pm 50^{\circ}\text{C}$ of the calibration temperature). The offset, determined by the single-point calibration, can be used to compensate for inaccuracies in the RTD module and cable combination.

After single-point calibration is performed, additional calibrations only need to be performed if the cable is disturbed or degraded. (RTD replacement should not affect the accuracy of the procedure.) However, periodic autocalibrations should be performed. Follow the steps below to perform a single-point calibration:

1. Cycle power to the SLC 500 chassis.
2. Select a calibration temperature that is near the control point ($\pm 10^{\circ}\text{C}$).
3. Determine the exact resistance ($\pm 0.01 \Omega$) equivalent to the calibration temperature by using a published temperature vs. resistance chart.
4. Replace the RTD with the fixed-precision resistor. (We recommend you use a 2 ppm temperature coefficient resistor.)
5. Use the RTD module to determine the temperature equivalent to the fixed precision resistor and cable combination.
6. Calculate the offset value by subtracting the calculated calibration temperature from the measured temperature.
7. Reconnect the RTD to the cable.
8. Use ladder logic to apply (subtract) the offset from the measured temperature to obtain corrected temperature.

Preliminary Operating Considerations

This chapter explains how the RTD module and the SLC processor communicate through the module's input and output image. It lists the preliminary setup and operation required before the RTD module can function in a 1746 I/O system. Topics discussed include how to:

- enter the module ID code
- address your RTD module
- select the proper input filter for each channel
- calculate the RTD module update time
- interpret the RTD module response to slot disabling

Module ID Code

The module identification code is a unique number encoded for each 1746 I/O module. The code defines for the processor the type of I/O or specialty module residing in a specific slot in the 1746 chassis.

To manually enter the module ID code, select (*other*) from the list of modules on the system I/O configuration display. The module ID code for the RTD module is shown below:

Operating Class	ID Code
Class 1	3508
Class 3	12708

No special I/O configuration information is required for Class 1. The module ID code automatically assigns the correct number of input and output words. For Class 3 the user must assign the correct number of input and output words (16 and 24).

Module Addressing

The memory map shown in the following illustration displays how the output and input image tables are defined for the RTD module.

Figure 3.1 Class 1 Memory Map

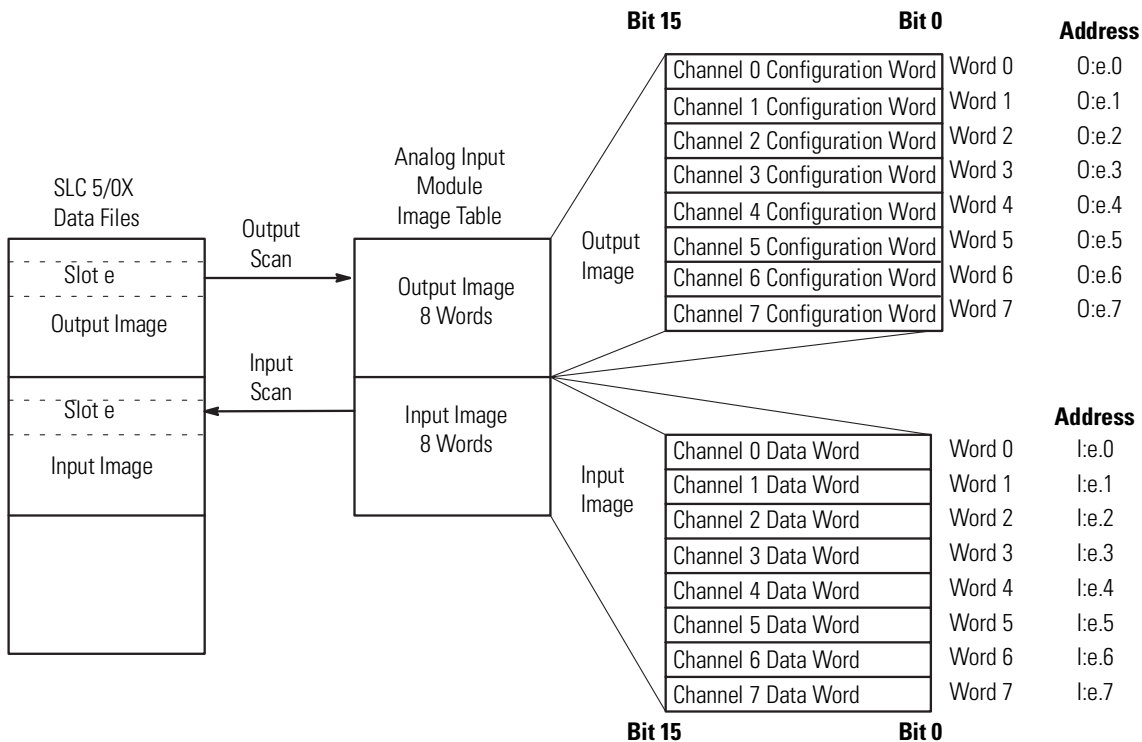
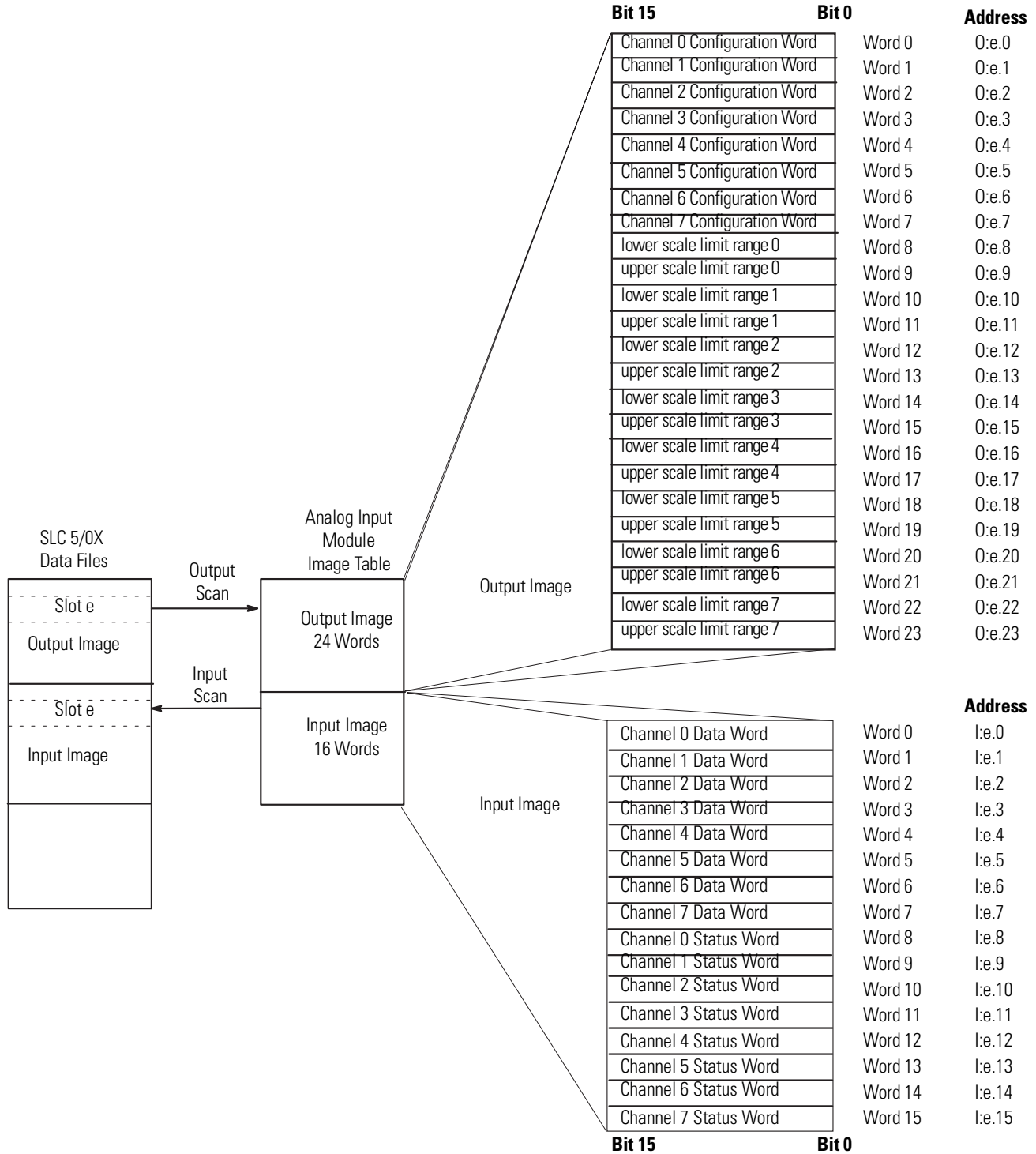

Figure 3.2 Class 3 Memory Map



Output Image - Configuration Words

The RTD module output image (defined as the output from the CPU to the RTD module) contains information that you configure to define the way a specific channel on the RTD module works. The 1746-NR8 uses an 8-word output image when operating in a Class 1 mode and 24-word output image when operating in Class 3 mode. These words take the place of configuration DIP switches on the module. Output words 0 through 7 are used to define the operation of the module; output words 8 through 23 are used for special user-set scaling using the proportional counts data format. Each output word 0 through 7 configures a single channel.

Example - If you want to configure channel 2 on the RTD module located in slot 4 in the SLC chassis, your address would be O:4.2.

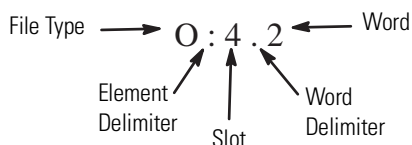

Chapter 4 gives you detailed bit information about the data content of the configuration word.

Input Image - Data Words and Status Words

The 8-word RTD module input image (defined as the input from the RTD module to the CPU) represents data words and status words.

Input words 0 through 7 (data words) hold the input data that represent the temperature value of the RTD input or ohmic value of the resistance inputs for channels 0 through 7. This data word is valid only when the channel is enabled and there are no channel errors.

When operating in Class 3 mode, input words 8 through 15 (status words) contain the status of channels 0 through 7 respectively. The status bits for a particular channel reflect the configuration settings that you have entered into the output image configuration word for that channel and provide information about the channel's operational state. To receive valid status information, the channel must be enabled and the channel must have processed any configuration changes that may have been made to the configuration word.

Example - To obtain the status of channel 2 (input word 6) of the RTD module located in slot 3 in the SLC chassis, use address I:3.6.

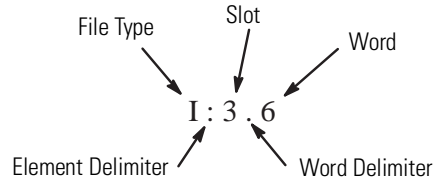

Chapter 4 gives you detailed bit information about the content of the data word and the status word.

Channel Filter Frequency Selection

The RTD module uses a digital filter that provides noise rejection for the input signals. The digital filter is programmable, allowing you to select from four filter frequencies for each channel.

Selecting a low value (for example, 28 Hz) for the channel filter frequency provides greater noise rejection for a channel, but also increases the channel update time. Selecting a high value for the channel filter frequency provides lesser noise rejection, but decreases the channel update time.

The Notch Frequencies table in the next section shows the available filter frequencies, as well as the associated minimum normal mode rejection (NMR), cut-off frequency, and step response for each filter frequency. The graphs on page 3-8 and page 3-9 show the input channel frequency response for each filter frequency selection.

1746-NR8 Channel Step Response

The channel filter frequency determines the channel's step response. The step response is the time required for the analog input signal to reach 100% of its expected final value. This means that if an input signal changes faster than the channel step response, a portion of that signal is attenuated by the channel filter. The table below shows the step response for each filter frequency.

Table 3.1 Notch Frequencies

Filter Frequency	50 Hz NMR	60 Hz NMR	3 dB Cut-Off Frequency	Step Response
28 Hz	110 dB	95 dB	7.80 Hz	120 msec
50/60 Hz	65 dB	65 dB	13.65 Hz	68.6 msec
800 Hz	-	-	209.8 Hz	3.75 msec
6400 Hz	-	-	1677 Hz	1.47 msec

Effective Resolution

The effective resolution for an input channel depends upon the filter frequency selected for that channel. The following table displays the effective resolution for the various input types and filter frequencies:

Table 3.2 Effective Resolution for RTD and Resistance Inputs

Input Type	Filter Frequency			
	28 Hz	50/60 Hz	800 Hz	6400 Hz
100Ω Pt RTD (385) ⁽¹⁾	± 0.1°C (± 0.1°F)	± 0.1°C (± 0.1°F)	± 0.2°C (± 0.4°F)	± 0.8°C (± 1.4°F)
200Ω Pt RTD (385) ⁽¹⁾	± 0.1°C (± 0.1°F)	± 0.1°C (± 0.1°F)	± 0.2°C (± 0.4°F)	± 0.8°C (± 1.4°F)
500Ω Pt RTD (385) ⁽¹⁾	± 0.1°C (± 0.1°F)	± 0.1°C (± 0.1°F)	± 0.2°C (± 0.4°F)	± 0.8°C (± 1.4°F)
1000Ω Pt RTD (385) ⁽¹⁾	± 0.1°C (± 0.1°F)	± 0.1°C (± 0.1°F)	± 0.2°C (± 0.4°F)	± 0.8°C (± 1.4°F)
100Ω Pt RTD (3916) ⁽¹⁾	± 0.1°C (± 0.1°F)	± 0.1°C (± 0.1°F)	± 0.2°C (± 0.4°F)	± 0.8°C (± 1.4°F)
200Ω Pt RTD (3916) ⁽¹⁾	± 0.1°C (± 0.1°F)	± 0.1°C (± 0.1°F)	± 0.2°C (± 0.4°F)	± 0.8°C (± 1.4°F)
500Ω Pt RTD (3916) ⁽¹⁾	± 0.1°C (± 0.1°F)	± 0.1°C (± 0.1°F)	± 0.2°C (± 0.4°F)	± 0.8°C (± 1.4°F)
1000Ω Pt RTD (3916) ⁽¹⁾	± 0.1°C (± 0.1°F)	± 0.1°C (± 0.1°F)	± 0.2°C (± 0.4°F)	± 0.8°C (± 1.4°F)
10Ω Cu RTD (426) ⁽¹⁾⁽²⁾	± 0.1°C (± 0.1°F)	± 0.1°C (± 0.2°F)	± 0.4°C (± 0.7°F)	± 1.0°C (± 1.8°F)
120Ω Ni RTD (618) ⁽¹⁾⁽³⁾	± 0.1°C (± 0.1°F)	± 0.1°C (± 0.1°F)	± 0.1°C (± 0.1°F)	± 0.3°C (± 0.5°F)
120Ω Ni RTD (672) ⁽¹⁾	± 0.1°C (± 0.1°F)	± 0.1°C (± 0.1°F)	± 0.1°C (± 0.1°F)	± 0.3°C (± 0.5°F)
604Ω NiFe RTD (518) ⁽¹⁾	± 0.1°C (± 0.1°F)	± 0.1°C (± 0.1°F)	± 0.1°C (± 0.1°F)	± 0.3°C (± 0.5°F)
150Ω Resistance Input	± 0.01Ω	± 0.01Ω	± 0.02Ω	± 0.08Ω
500Ω Resistance Input	± 0.1Ω	± 0.1Ω	± 0.1Ω	± 0.4Ω
1000Ω Resistance Input	± 0.1Ω	± 0.1Ω	± 0.2Ω	± 0.6Ω
3000Ω Resistance Input	± 0.1Ω	± 0.1Ω	± 0.3Ω	± 1.0Ω

(1) The digits following the RTD type represent the temperature coefficient of resistance (α), which is defined as the resistance change per ohm per °C. For instance, Platinum 385 refers to a platinum RTD with $\alpha = 0.00385$ ohms/ohm-°C or simply 0.00385 /°C.

(2) Actual value at 0°C is 9.042Ω per SAMA standard RC21-4-1966.

(3) Actual value at 0°C is 100Ω per DIN standard.

Channel Cut-Off Frequency

The channel filter frequency selection determines a channel's cut-off frequency, also called the -3 dB frequency. The cut-off frequency is defined as the point on the input channel frequency response curve where frequency components of the input signal are passed with 3 dB of attenuation. All frequency components at or below the cut-off frequency are passed by the digital filter with less than 3 dB of attenuation. All frequency components above the cut-off frequency are increasingly attenuated, as shown in the following illustrations.

The cut-off frequency for each input channel is defined by its filter frequency selection. The table on page 3-5 shows the input channel cut-off frequency for each filter frequency. Choose a filter frequency so that your fastest changing signal is below that of the filter's cut-off frequency. The cut-off frequency should not be confused with update time. The cut-off frequency relates how the digital filter attenuates frequency components of the input signal. The update time defines the rate at which an input channel is scanned and its channel data word updated. See page 3-10 for determining the channel update time.

Figure 3.3 28 Hz Filter Frequency Response

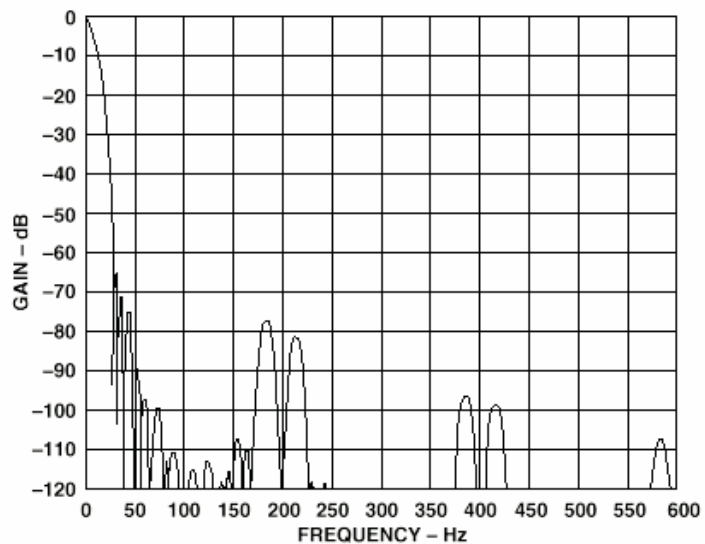

Figure 3.4 50/60 Hz Filter Frequency Response

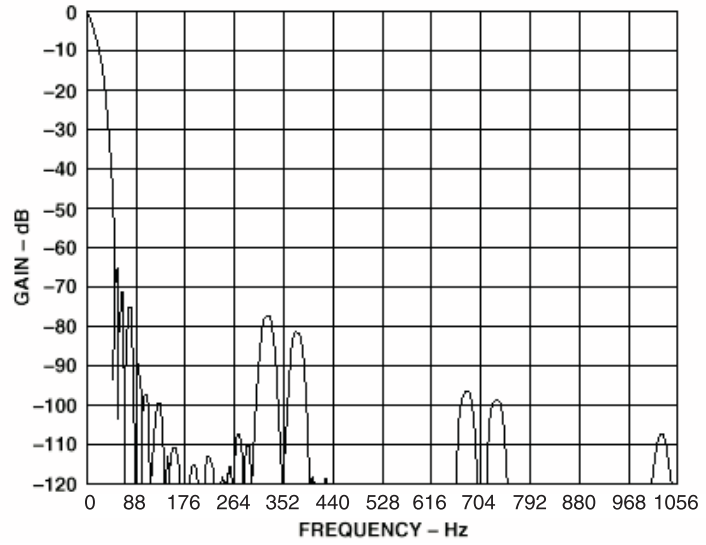

Figure 3.5 800 Hz Filter Frequency Response

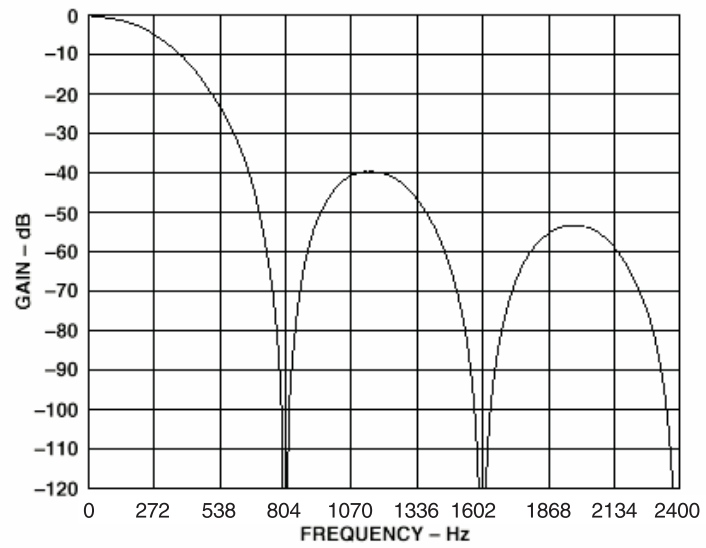
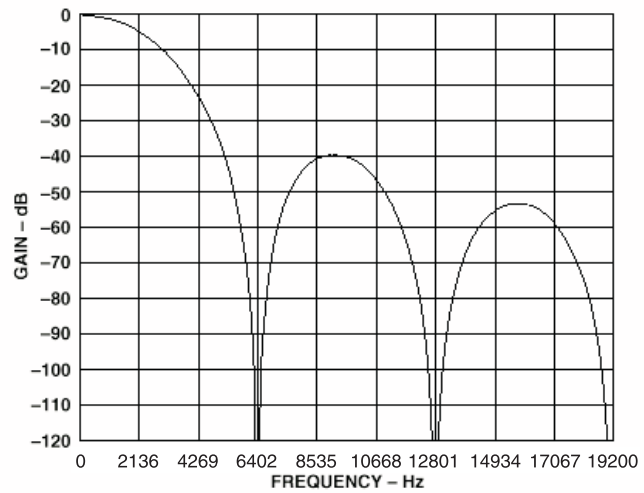

Figure 3.6 6400 Hz Filter Frequency Response

This section shows how to determine the channel update time and channel autocalibration time. In addition, the scanning process is briefly described.

The RTD module channel update time is defined as the time required for the module to sample and convert (scan) the input signal of an enabled input channel and make the resulting data value available to the SLC processor for update.

Channel Autocalibration

Upon entry into the channel enabled state, the module configures that channel and performs an autocalibration on the module if the combination of input and excitation current are unique to that channel. Module calibration takes precedence over channel scanning. Module calibration time is dependent on the number of unique input type and excitation current combinations and is equal to 510 msec +(125 msec x number of unique combinations).

Update Time and Scanning Process

The illustration on page 3-11 shows the scanning process for the RTD module assuming that the module is running normally and more than one channel is enabled. The scanning cycle is shown for the situation where channels 0 and 1 are enabled and channels 2 through 7 are not used.

Channel scan time is a function of the filter frequency, as shown in the following table:

Table 3.3 Channel Scan Time

Filter Frequency	Channel Scan Time ⁽¹⁾	With Lead Resistance
28 Hz	125 ms	250 ms
50/60 Hz	75 ms	147 ms
800 Hz	10 ms	18 ms
6400 Hz	6 ms	10 ms

(1) The module-scan time is obtained by summing up the channel-scan time for each enabled channel. For example, if 3 channels are enabled with lead resistance and the 50/60 Hz filter is selected, the module-scan time is 3 x 147 ms = 441 ms.

The *fastest module update time* occurs when only one channel with a 6400 Hz filter frequency is enabled and lead resistance measurement is disabled.

Module Update Time = 6 ms

With 3 channels enabled, the module update time is:
 3 channels x 6 ms/channel = 18 ms. The *slowest module update time* occurs when eight channels, each using a 28 Hz filter frequency and with lead resistance measurement always enabled.

Module Update Time = 8 x 250 ms = 2000 ms

Figure 3.7 Scanning Cycle

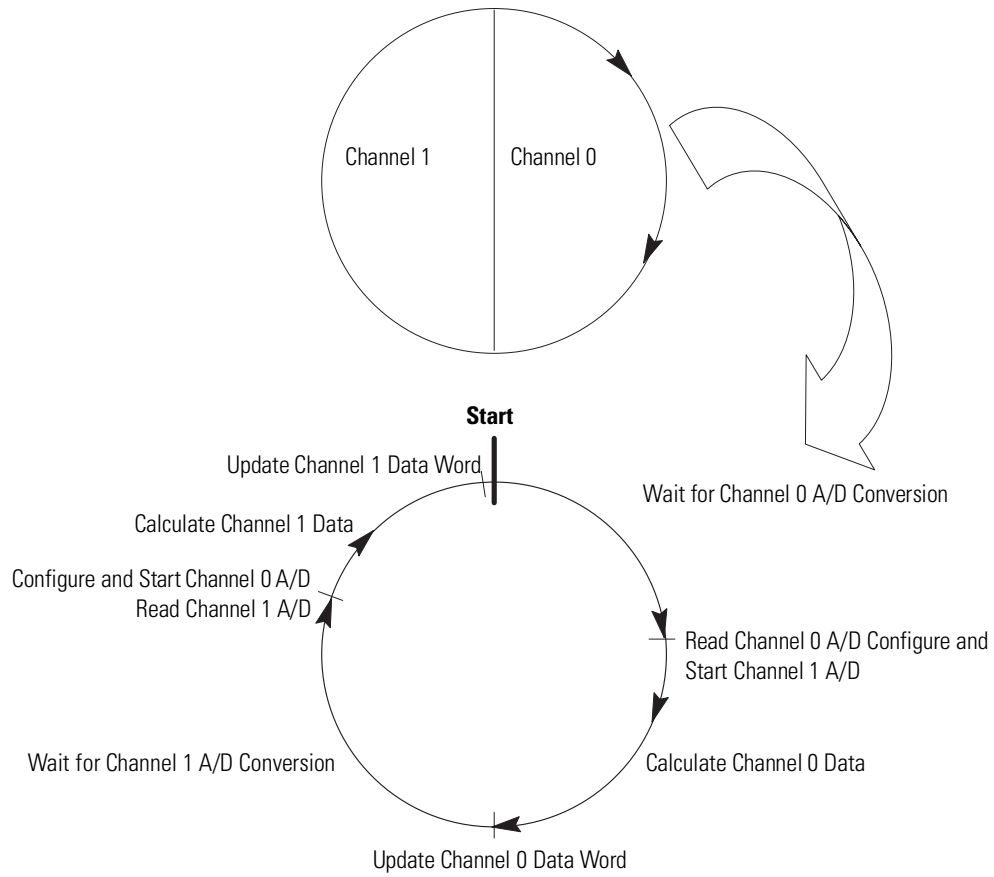

The table below gives you the turn-on, turn-off, and reconfiguration times for enabling or disabling a channel.

	Description	Duration
Turn-On Time	The time it takes to make converted data available in the data word and to set the status bit (transition from 0 to 1) in the status word, after setting the enable bit in the configuration word.	Requires up to one module update time plus 510 msec + 125 milliseconds x the number of unique input type and excitation current combinations.
Turn-Off Time	The time it takes to reset the status bit (transition from 1 to 0) in the status word and to zero the data word, after resetting the enable bit in the configuration word.	Requires up to one module update time.
Reconfiguration Time	The time it takes to change a channel configuration if the new device type and excitation current are a unique combination. The enable bit remains in a steady state of 1. (Changing temperature/resistance units or data format does not require reconfiguration time.)	Requires up to one module update time plus 510 msec + 125 milliseconds x the number of unique input type and excitation current combinations.

By writing to the status file in your modular SLC processor you can disable any chassis slot. Refer to your SLC programming manual for the slot disable/enable procedure.

Input Response

When an RTD slot is disabled, the RTD module continues to update its input image table. However, the SLC processor does not read inputs from a module that is disabled. Therefore, when the processor disables the RTD module slot, the module inputs appearing in the processor input image remain in their last state and the module's updated image table is not read. When the processor re-enables the module slot, the current state of the module inputs are read by the processor during the subsequent scan.

Output Response

The SLC processor may change the RTD module output data (configuration) as it appears in the processor output image. However, this data is not transferred to the RTD module when the slot is disabled. The outputs are held in their last state. When the slot is re-enabled, the data in the processor image is transferred to the RTD module.

Channel Configuration, Data, and Status

This chapter examines the channel configuration word and the channel status word bit by bit, and explains how the module uses configuration data and generates status during operation. It gives you information about how to:

- configure a channel
- examine channel input data
- check a channel's status

Channel Configuration

The channel configuration word is a part of the RTD module's output image as shown in the illustration below. Output words 0 through 7 correspond to channels 0 through 7 on the module. Setting the condition of bits 0 through 15 in these words via your ladder logic program causes the channel to operate as you choose (for example, RTD type, reading in °C). Output words 8 through 23 (Class 3 only) are used to further define the channel configuration to allow you to choose a scaling format other than the module default when using the proportional counts data format. You can use words 8 and 9 to define a user-set range for channel 0, words 10 and 11 for channel 1, etc.

A bit-by-bit examination of the configuration word is provided in the table on page 4-5. Programming is discussed in Chapter 5. Addressing is explained in Chapter 3.

Figure 4.1 Module Output Image (Configuration Word)

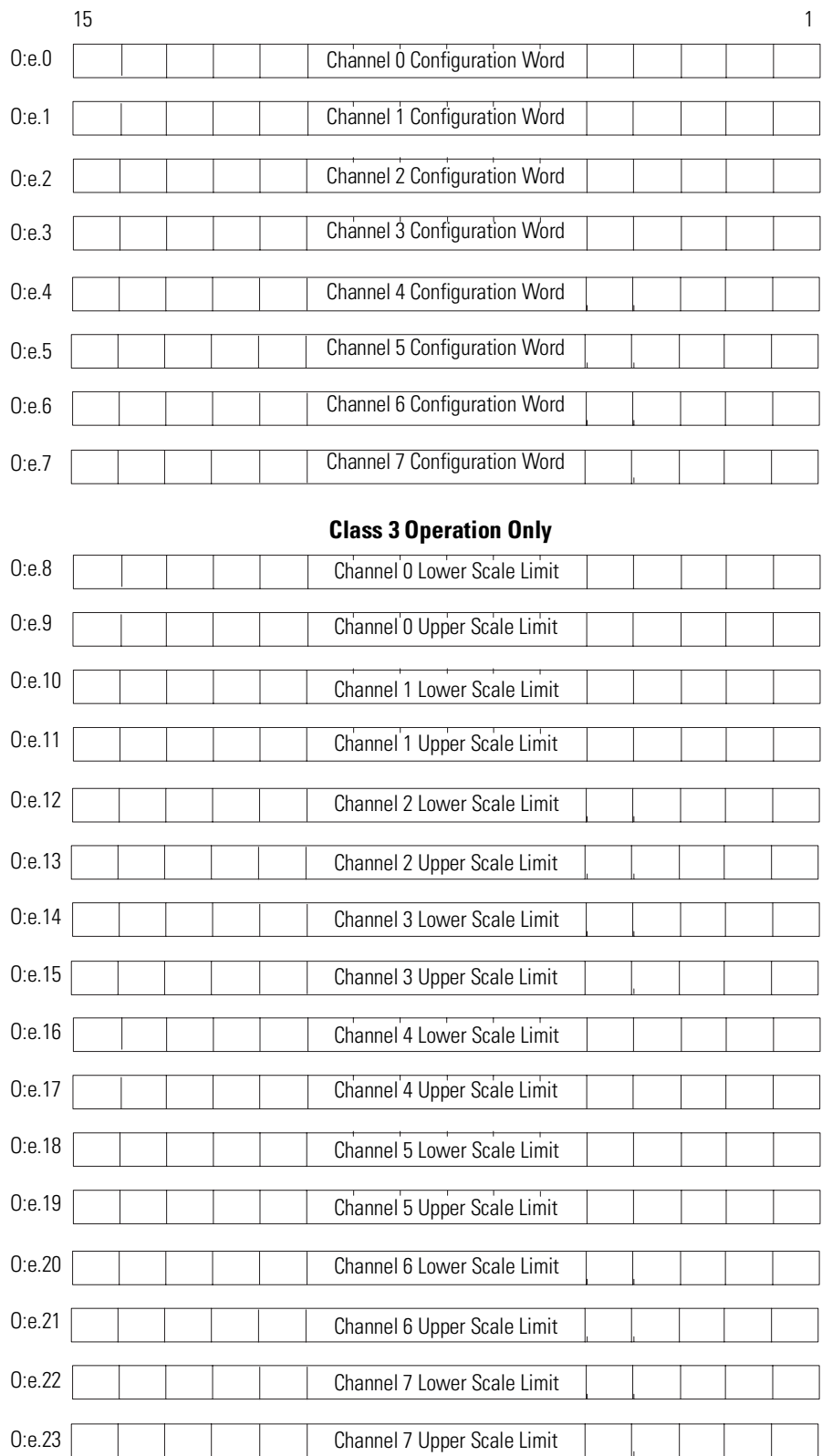

Module default settings for configuration words 0 through 7 are all zeros. Scaling defaults are explained on page 4-9 under the explanation for the User-set Scaling Select bits 13 and 14.

Channel Configuration Procedure

The channel configuration word consists of bit fields, the settings of which determine how the channel operates. This procedure looks at each bit field separately and helps you configure a channel for operation. Refer to the table on page 4-5 and the bit field descriptions that follow for complete configuration information. See page B-1 for a configuration worksheet that can assist your channel configuration.

Configure Each Channel

1. Determine the input device type (RTD type or resistance input) for a channel and enter its respective 4-digit binary code in bit field 0-3 (Input Type Selection) of the channel configuration word.
2. Select a data format for the data word value. Your selection determines how the analog input value from the A/D converter is expressed in the data word. Enter your 2-digit binary code in bit field 4 and 5 (Data Format Selection) of the channel configuration word. If you have chosen proportional counts data format, you may define the scaling range. The default values for the limit registers are 0. If the lower limit and the upper limit are both 0, the module uses -32,768 as the lower limit and +32,767 as the upper limit. If the lower limit is equal to the upper limit, a configuration error occurs. Otherwise, the module uses limit values in these registers. Make sure to enter the lower and upper limits in the scale limit registers for that channel, if you want user-defined scaling. An example on page 4-9 (user-set scaling) explains how to do this.
3. Determine the desired state for the channel data word if a broken input condition is detected for that channel (open-circuit or short-circuit). Enter the 2-digit binary code in bit field 6 and 7 (Broken Input Selection) of the channel configuration word.
4. If the channel is configured for RTD inputs and engineering units data format, determine if you want the channel data word to read in degrees Fahrenheit or degrees Celsius and enter a one or a zero in bit 8 (Temperature Units) of the configuration word. If the channel is configured for a resistance input, this field is ignored.

5. Determine the desired input filter frequency for the channel and enter the 2-digit binary code in bit 9 and 10 (Filter Frequency Selection) of the channel configuration word. A lower filter frequency increases the channel update time, but also increases the noise rejection and channel resolution. A higher filter frequency decreases the channel update time, but also decreases the noise rejection and channel resolution.
6. Determine which channels are used in your program and enable them. Place a one in bit 11 (channel Enable) if the channel is to be used. Place a zero in bit 11 if the channel will not be used.
7. Select the excitation current for the input channel. A zero in bit 12 provides an excitation current of 1.0 mA; a 1 provides 0.25 mA. Select the excitation current value based on RTD vendor recommendations and the *Input Specifications* table, page A-2.
8. Select the lead resistance measurement option. The module can disable lead resistance measurement, periodically measure the lead resistance, or measure the lead resistance on each acquisition for each one of the 8 channels. Setting a channel's lead-resistance enable bits to 00 disables the lead resistance measurement. Setting a channel's lead resistance enable bits 01 enables the periodic measurement of the lead resistance, which occurs once every 5 minutes. Setting a channel's lead resistance enable bits to 10 enables measurement of the lead resistance on each acquisition cycle.
9. Build the channel configuration word using the configuration worksheet on page B-1 for every channel on each RTD module repeating the procedures given in steps 1 through 9.

Enter the Configuration Data

Following the steps outlined in Chapter 5 (*Ladder Programming Examples*), enter your configuration data into your ladder program and copy it to the RTD module.

Table 4.1 Channel Configuration Word (O:e.0 through O:e.7) - Bit Definitions

Define	To Select	Make these bit settings in the Channel Configuration Word															
		15	14	13	12	11	10	9	8	7	6	5	4	3	2	1	0
Input type selection	100 Pt (385)													0	0	0	0
	200 Pt (385)													0	0	0	1
	500 Pt (385)													0	0	1	0
	1000 Pt (385)													0	0	1	1
	100 Pt (3916)													0	1	0	0
	200 Pt (3916)													0	1	0	1
	500 Pt (3916)													0	1	1	0
	1000 Pt (3916)													0	1	1	1
	10 Cu (426) ⁽¹⁾													1	0	0	0
	120 Ni (618) ⁽²⁾													1	0	0	1
	120 Ni (672)													1	0	1	0
	604 NiFe (518)													1	0	1	1
	150Ω Resistance Input													1	1	0	0
	500Ω Resistance Input													1	1	0	1
	1000Ω Resistance Input													1	1	1	0
3000Ω Resistance Input													1	1	1	1	
Data format selection	Engineering units x 1 ⁽³⁾												0	0			
	Engineering units x 10 ⁽⁴⁾												0	1			
	Scaled-for-PID												1	0			
	proportional counts												1	1			
Broken input selection	Set to Zero												0	0			
	Set to Upscale												0	1			
	Set to Downscale												1	0			
	Invalid												1	1			
Temperature units selection	Degrees C ⁽⁵⁾											0					
	Degrees F ⁽⁵⁾											1					
Filter frequency selection	28 Hz								0	0							
	50/60 Hz								0	1							
	800 Hz								1	0							
	6400 Hz								1	1							
Channel enable	Channel Disabled								0								
	Channel Enabled								1								
Excitation current selection	1.0 mA								0								
	0.25 mA								1								
Cal. Disable	Enable								0								
	Disable								1								
Lead R. Enable	Disable	0	0														
	Periodic	0	1														
	Always	1	0														
	Invalid	1	1														

(1) Actual value at 0 °C is 9.042Ω per SAMA standard RC21-4-1966.

(2) Actual value at 0 °C is 100Ω per DIN standard.

(3) Values are in 0.1 degree /step or 0.1Ω/step for all resistance input types, except 150Ω. For the 150Ω resistance input type, the values are in 0.01Ω/step.

(4) Values are in 1 degree /step or 1Ω/step for all resistance input types, except 150Ω. For the 150Ω resistance input type, the values are in 0.1Ω/step.

(5) This bit is ignored when a resistance device is selected.

Input Type Selection (Bits 0 through 3)

The input type bit field lets you configure the channel for the type of input device you have connected to the module. Valid input devices are shown in the previous table.

Data Format Selection (Bits 4 and 5)

The data format bit field lets you define the format for the channel data word contained in the module input image. Valid data types are engineering units, scaled-for-PID, and proportional counts. If you select proportional counts and are operating in Class 3, you have the option of using user-defined scaling (output registers O:8 through O:23). Unless you specify otherwise, the data is scaled to the full scale range for that channel.

Table 4.2 Bit Descriptions for Data Format Select

Binary Value	Select	Description
00	engineering units x 1	Express values in 0.1 degree or 0.1 Ω or 0.01 Ω for 150 Ω pot., only
01	engineering units x 10	Express values in 1 degree or 1 Ω or 0.1 Ω for 150 Ω pot., only.
10	scaled-for-PID	The input signal range for the selected input type is its full scale input range. The signal range is scaled into a 0 to 16383 range, which is what the SLC processor expects in the PID function.
11	proportional counts	The input signal range is proportional to your selected input type and scaled into a -32768 to +32767 range (default) or user-set range, based on the scale limit words (O:e.8 to O:e.23)

Using Scaled-For-PID and Proportional Counts Formats

The RTD module provides eight options for displaying input channel data. These are 0.1°F, 0.1°C, 1°F, 1°C, 0.1 Ω , 1 Ω , Scaled-for-PID, and Proportional Counts. The first six options represent real engineering units and do not require explanation. The Scaled-for-PID selection allows you to directly interface RTD Data into a PID instruction without intermediate scale operations and Proportional Counts selection provides the highest display resolution, but also require you to manually convert the channel data to real Engineering Units.

Default scaling can be selected for scaled-for-PID data format and proportional counts data format. *User-set scaling* can be defined for proportional counts data format. For a description of default scaling, see page 4-7 (scaled-for-PID data format) and page 4-8 (proportional counts data format). For a description of user-set scaling using proportional counts data format, see page 4-9.

The equations on page 4-11 show how to convert from Scaled-for-PID to Engineering Units, Engineering Units to Scaled-for-PID, Proportional Counts to Engineering Units, and Engineering Units to Proportional Counts. To perform the conversions, you must know the defined temperature or resistance range for the channel's input type. Refer to the Channel Data Word Format in the tables on page 4-13 and page 4-14. The lowest possible value for an input type is S_{LOW} and the highest possible value is S_{HIGH} .

Scaled-for-PID - If the user selects scaled-for-PID as the data format, the data word for that channel is a number between 0 and 16383. Zero (0) corresponds to the lowest temperature value of the RTD type or the lowest resistance value (ohms). The value 16383 corresponds to the highest temperature value for that RTD or the highest resistance value (ohms). For example, if a 100 Ω Platinum RTD ($\alpha = 0.003916$) is selected, then the relationship of temperature and module counts is:

Temperature	Counts
-200°C	0
+630°C	16383

The following illustration shows the linear relationship between output counts and temperature when one uses scaled-or-PID data format.

Figure 4.2 Linear Relationship Between Temperature and PID Counts

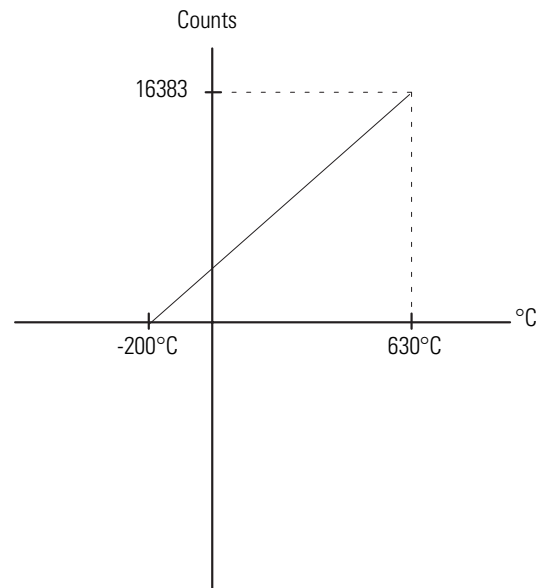

Proportional Counts Data Format - If the user selects proportional counts data format and uses the default limits of 0, the data word for that channel is a number between -32,768 and +32,767. This provides the greatest resolution of all scaling options. The value -32,768 corresponds to the lowest temperature value of the RTD type or the lowest resistance value (ohms). The value 32,767 corresponds to the highest temperature value for that RTD or the highest resistance value (ohms). For example, if a 100 Ω Platinum RTD (3916) is selected, then the relationship of temperature and module counts is:

Temperature	Counts
-200°C	-32768
+630°C	+32767

The following illustration shows the linear relationship between output counts and temperature when one uses proportional counts data format.

Figure 4.3 Linear Relationship Between Temperature and Proportional Counts

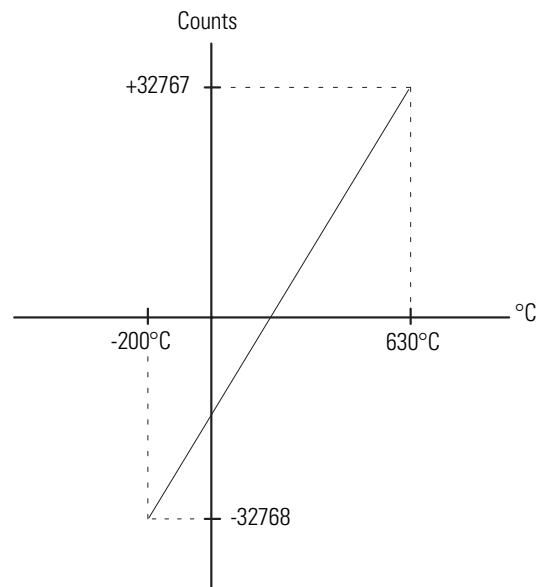

User-Set Scaling

Proportional Counts - If the user wants to configure the module to scale the data word to something other than -32,768 to +32,767, the user defines what the upper and lower limits are going to be. However, the maximum range remains -32,768 to +32,767. The user defines what the upper and lower limits are going to be by placing the range in the user-set scaling words for that channel. The module scales the input data to the upper and lower limit in an linear relationship. The following example clarifies this feature. In this example, the RTD module channel that is configured for user-set scaling is channel 3. As shown in the following illustration, the user has programmed the channel 3 configuration word for 1000Ω potentiometer (bits 0 to 3): proportional counts data format (bits 4 and 5): and configuration words 14 and 15 for scaling. The program for the following example is described on page 5-4 in chapter 5.

The user desires to control the line speed of a conveyor. A 1000Ω potentiometer is used to sense the conveyor line speed. The line speed varies between 3 ft./minute (0 ohms) and 50 ft./minute (1000 ohms).

As shown in the illustration on below, the user selects a 1000Ω potentiometer as the input type. If the user chooses engineering units as the data format, the module data word is a value between 0 and 1000 ohms. However, if the user chooses the proportional counts data format and utilizes the user-set scaling feature, the number 3 can be entered in O:e.14 and the number 50 in O:e.15. In this situation, the RTD module returns a number between 3 and 50 in its data word. This action saves the user time in ladder programming.

Figure 4.4 User-set Scaling Using Proportional Counts Data Format

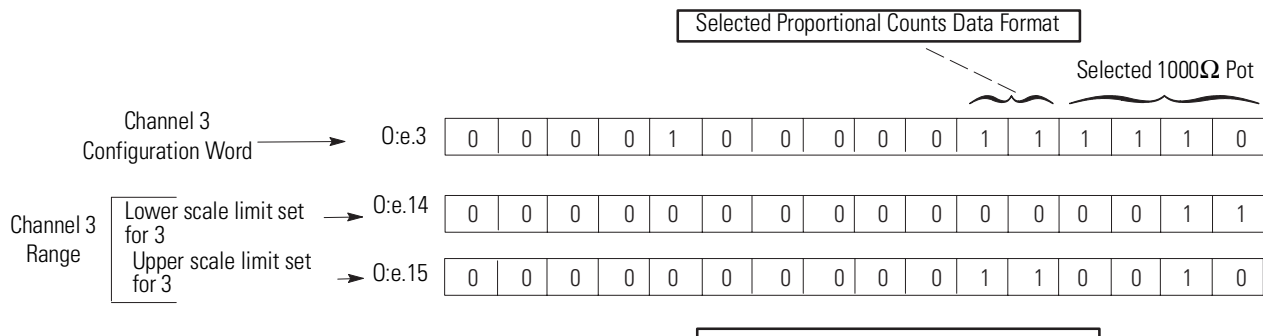

Configuration Words For User-set Scaling (Words 8 to 23)

The following illustration shows the address of the user-set limit scale words used to define the lower value and the upper value of the user-set scale words. You can use the words for a channel when proportional counts mode is selected for that channel

Any time proportional counts is selected and the upper limit is not zero, but is equal to the lower limit, a configuration error occurs. For example, if both scaling limits are 0, or if the lower range value is greater than or equal to the upper range value, a configuration error occurs.

Figure 4.5 Limit Scale Words

Channel 0	O:e.8	<input type="text"/>	<input type="text"/>	<input type="text"/>	<input type="text"/>	<input type="text"/>	Defines lower scale limit for Ch 0	<input type="text"/>	<input type="text"/>	<input type="text"/>	<input type="text"/>	<input type="text"/>
	O:e.9	<input type="text"/>	<input type="text"/>	<input type="text"/>	<input type="text"/>	<input type="text"/>	Defines upper scale limit for Ch 0	<input type="text"/>	<input type="text"/>	<input type="text"/>	<input type="text"/>	<input type="text"/>
Channel 1	O:e.10	<input type="text"/>	<input type="text"/>	<input type="text"/>	<input type="text"/>	<input type="text"/>	Defines lower scale limit for Ch 1	<input type="text"/>	<input type="text"/>	<input type="text"/>	<input type="text"/>	<input type="text"/>
	O:e.11	<input type="text"/>	<input type="text"/>	<input type="text"/>	<input type="text"/>	<input type="text"/>	Defines upper scale limit for Ch 1	<input type="text"/>	<input type="text"/>	<input type="text"/>	<input type="text"/>	<input type="text"/>
Channel 2	O:e.12	<input type="text"/>	<input type="text"/>	<input type="text"/>	<input type="text"/>	<input type="text"/>	Defines lower scale limit for Ch 2	<input type="text"/>	<input type="text"/>	<input type="text"/>	<input type="text"/>	<input type="text"/>
	O:e.13	<input type="text"/>	<input type="text"/>	<input type="text"/>	<input type="text"/>	<input type="text"/>	Defines upper scale limit for Ch 2	<input type="text"/>	<input type="text"/>	<input type="text"/>	<input type="text"/>	<input type="text"/>
Channel 3	O:e.14	<input type="text"/>	<input type="text"/>	<input type="text"/>	<input type="text"/>	<input type="text"/>	Defines lower scale limit for Ch 3	<input type="text"/>	<input type="text"/>	<input type="text"/>	<input type="text"/>	<input type="text"/>
	O:e.15	<input type="text"/>	<input type="text"/>	<input type="text"/>	<input type="text"/>	<input type="text"/>	Defines upper scale limit for Ch 3	<input type="text"/>	<input type="text"/>	<input type="text"/>	<input type="text"/>	<input type="text"/>
Channel 4	O:e.16	<input type="text"/>	<input type="text"/>	<input type="text"/>	<input type="text"/>	<input type="text"/>	Defines lower scale limit for Ch 4	<input type="text"/>	<input type="text"/>	<input type="text"/>	<input type="text"/>	<input type="text"/>
	O:e.17	<input type="text"/>	<input type="text"/>	<input type="text"/>	<input type="text"/>	<input type="text"/>	Defines upper scale limit for Ch 4	<input type="text"/>	<input type="text"/>	<input type="text"/>	<input type="text"/>	<input type="text"/>
Channel 5	O:e.18	<input type="text"/>	<input type="text"/>	<input type="text"/>	<input type="text"/>	<input type="text"/>	Defines lower scale limit for Ch 5	<input type="text"/>	<input type="text"/>	<input type="text"/>	<input type="text"/>	<input type="text"/>
	O:e.19	<input type="text"/>	<input type="text"/>	<input type="text"/>	<input type="text"/>	<input type="text"/>	Defines upper scale limit for Ch 5	<input type="text"/>	<input type="text"/>	<input type="text"/>	<input type="text"/>	<input type="text"/>
Channel 6	O:e.20	<input type="text"/>	<input type="text"/>	<input type="text"/>	<input type="text"/>	<input type="text"/>	Defines lower scale limit for Ch 6	<input type="text"/>	<input type="text"/>	<input type="text"/>	<input type="text"/>	<input type="text"/>
	O:e.21	<input type="text"/>	<input type="text"/>	<input type="text"/>	<input type="text"/>	<input type="text"/>	Defines upper scale limit for Ch 6	<input type="text"/>	<input type="text"/>	<input type="text"/>	<input type="text"/>	<input type="text"/>
Channel 7	O:e.22	<input type="text"/>	<input type="text"/>	<input type="text"/>	<input type="text"/>	<input type="text"/>	Defines lower scale limit for Ch 7	<input type="text"/>	<input type="text"/>	<input type="text"/>	<input type="text"/>	<input type="text"/>
	O:e.23	<input type="text"/>	<input type="text"/>	<input type="text"/>	<input type="text"/>	<input type="text"/>	Defines upper scale limit for Ch 7	<input type="text"/>	<input type="text"/>	<input type="text"/>	<input type="text"/>	<input type="text"/>

Scaling Examples

The following examples are using the default scaling ranges:

Scaled-for-PID to Engineering Units

Equation:

$$\text{Engr Units Equivalent} = \text{SLOW} + \left[(\text{SHIGH} - \text{SLOW}) \times \left(\frac{\text{Scaled-for-PID value displayed}}{16383} \right) \right]$$

Assume that the input type is an RTD, Platinum (200Ω, α = 0.00385°C, range = -200°C to +850°C), scaled-for-PID display type. Channel data = 3421.

Want to calculate °C equivalent.

From Channel Data Word Format, S_{LOW} = -200°C and S_{HIGH} = 850°C.

Solution:

$$\text{Engr Units Equivalent} = 200^\circ\text{C} + \left[(850^\circ\text{C} - (-200^\circ\text{C})) \times \left(\frac{3421}{16383} \right) \right] = 19.25^\circ\text{C}$$

Engineering Units to Scaled-for-PID

Equation:

$$\text{Scaled-for-PID Equivalent} = 16383 \times \left[\frac{(\text{Engr Units desired} - \text{SLOW})}{(\text{SHIGH} - \text{SLOW})} \right]$$

Assume that the input type is an RTD, Platinum (200Ω, α = 0.00385°C, range = -200°C to +850°C), scaled-for-PID display type. Desired channel temperature = 344°C.

Want to calculate Scaled-for-PID equivalent.

From Channel Data Word Format, S_{LOW} = -200°C and S_{HIGH} = 850°C.

Solution:

$$\text{Scaled-for-PID Equivalent} = 16383 \times \left[\frac{344^\circ\text{C} + (-200^\circ\text{C})}{850^\circ\text{C} - (-200^\circ\text{C})} \right] = 8488$$

Proportional Counts to Engineering Units

Equation:

$$\text{Engr Units Equivalent} = \text{SLOW} + \left\{ (\text{SHIGH} - \text{SLOW}) \times \left[\frac{(\text{Proportional Counts value displayed} + 32768)}{65536} \right] \right\}$$

Assume that input type is a potentiometer (1000Ω, range = 0 to 1000Ω), proportional counts display type. Channel data = 21567.

Want to calculate ohms equivalent.

From Channel Data Word Format, S_{LOW} = 0Ω and S_{HIGH} = 1000Ω

Solution:

$$\text{Engr Units Equivalent} = 0 \Omega + \left\{ [1000 \text{ ohms} - 0 \text{ ohms}] \times \left[\frac{(21567 + 32768)}{65536} \right] \right\} = 826 \text{ ohms}$$

Engineering Units to Proportional Counts

Equation:

$$\text{Proportional Counts Equivalent} = \left\{ 65536 \times \left[\frac{(\text{Engr Units desired} - \text{SLOW})}{(\text{SHIGH} - \text{SLOW})} \right] \right\} - 32768$$

Assume that input type is a potentiometer (3000Ω, range = 0 to 3000Ω), proportional counts display type. Desired channel resistance value = 1809Ω. Want to calculate Proportional Counts equivalent.

From Channel Data Word Format, S_{LOW} = 0Ω and S_{HIGH} = 3000Ω

Solution:

$$\text{Prop. Counts} = \{65536 \times [1809 \text{ ohms} - 0 \text{ ohms}]\} - 32768 = 670$$

The following table shows the temperature ranges of several 1746-NR8 RTDs. The table applies to both 0.25 and 1.0 mA excitation currents. The temperature ranges of the remaining RTDs vary with excitation current, for example, 1000Ω Platinum 385, 1000Ω Platinum 3916, and 10Ω Copper 426.

Table 4.3 Data Formats for RTD Temperature Ranges for 0.25 and 1.0 mA Excitation Current

RTD Input Type	Data Format					
	Engineering Units x 1		Engineering Units x 10		Scaled-for-PID	Proportional Counts (Default)
	0.1°C	0.1°F	1.0°C	1.0°F		
100Ω Platinum (385)	-2000 to +8500	-3280 to +15620	-200 to +850	-328 to +1562	0 to 16383	-32768 to 32767
200Ω Platinum (385)	-2000 to +6300	-3280 to +6300	-200 to +630	-328 to +630	0 to 16383	-32768 to 32767
100Ω Platinum (3916)	-2000 to +6300	-3280 to +6300	-200 to +630	-328 to +630	0 to 16383	-32768 to 32767
200Ω Platinum (3916)	-2000 to +6300	-3280 to +6300	-200 to +630	-328 to +630	0 to 16383	-32768 to 32767
120Ω Nickel (672)	-800 to +2600	-3280 to +5000	-80 to +260	-328 to +500	0 to 16383	-32768 to 32767
120Ω Nickel (618) ⁽¹⁾	-1000 to +2600	-3280 to +5000	-100 to +260	-328 to +500	0 to 16383	-32768 to 32767
10Ω Copper (426)	-1000 to +2600	-3280 to +5000	-100 to +260	-328 to +500	0 to 16383	-32768 to 32767

(1) Actual value at 0 °C is 100Ω per DIN standard.

Table 4.4 Data Format for 500Ω Platinum RTD (385)

Excitation Current	Data Format					
	Engineering Units x 1		Engineering Units x 10		Scaled-for-PID	Proportional Counts (Default)
	0.1°C	0.1°F	1.0°C	1.0°F		
0.25 mA	-2000 to +8500	-3280 to +15620	-200 to +850	-328 to +1562	0 to 16383	-32768 to 32767
1.0 mA	-2000 to +3900	-3280 to +6980	-200 to +390	-328 to +698	0 to 16383	-32768 to 32767

Table 4.5 Data Format for 1000Ω Platinum RTD (385)

Excitation Current	Data Format					
	Engineering Units x 1		Engineering Units x 10		Scaled-for-PID	Proportional Counts (Default)
	0.1°C	0.1°F	1.0°C	1.0°F		
0.25 mA	-2000 to +8500	-3280 to +15620	-200 to +850	-328 to +1562	0 to 16383	-32768 to 32767
1.0 mA	-2000 to +500	-3280 to +1220	-200 to +50	-328 to +122	0 to 16383	-32768 to 32767

Table 4.6 Data Format for 500Ω Platinum RTD (3916)

Excitation Current	Data Format					
	Engineering Units x 1		Engineering Units x 10		Scaled-for-PID	Proportional Counts (Default)
	0.1°C	0.1°F	1.0°C	1.0°F		
0.25 mA	-2000 to +6300	-3280 to +11660	-200 to +630	-328 to +1166	0 to 16383	-32768 to 32767
1.0 mA	-2000 to +3800	-3280 to +6980	-200 to +380	-328 to +698	0 to 16383	-32768 to 32767

Table 4.7 Data Format for 1000Ω Platinum RTD (3916)

Excitation Current	Data Format					
	Engineering Units x 1		Engineering Units x 10		Scaled-for-PID	Proportional Counts (Default)
	0.1°C	0.1°F	1.0°C	1.0°F		
0.25 mA	-2000 to +6300	-3280 to +11660	-200 to +630	-328 to +1166	0 to 16383	-32768 to 32767
1.0 mA	-2000 to +500	-3280 to +1220	-200 to +50	-328 to +122	0 to 16383	-32768 to 32767

Table 4.8 Data Format for 604Ω Nickel Iron RTD (518)

Excitation Current	Data Format					
	Engineering Units x 1		Engineering Units x 10		Scaled-for-PID	Proportional Counts (Default)
	0.1°C	0.1°F	1.0°C	1.0°F		
0.25 mA	-2000 to +2000	-3280 to +3920	-200 to +200	-328 to +392	0 to 16383	-32768 to 32767
1.0 mA	-2000 to +1800	-3280 to +3380	-200 to +180	-328 to +338	0 to 16383	-32768 to 32767

The following tables show the resistance ranges provided by the 1746-NR8.

Table 4.9 Data Format for 150Ω Resistance Input

Resistance Input Type	Data Format			
	Engineering Units x 1	Engineering Units x 10	Scaled-for-PID	Proportional Counts (Default)
	0.01Ω ⁽¹⁾	0.1Ω ⁽¹⁾		
150Ω	0 to 15000	0 to 1500	0 to 16383	-32768 to 32767

(1) When ohms are selected, the temperature-units selection (bit 8) is ignored.

Table 4.10 Data Format for 500Ω and 1000Ω Resistance Input

Resistance Input Type	Data Format			
	Engineering Units x 1	Engineering Units x 10	Scaled-for-PID	Proportional Counts (Default)
	0.1 Ω ⁽¹⁾	1.0Ω ⁽¹⁾		
500Ω	0 to 5000	0 to 500	0 to 16383	-32768 to 32767
1000Ω	0 to 10000	0 to 1000	0 to 16383	-32768 to 32767

(1) When ohms are selected, the temperature-units selection (bit 8) is ignored.

Table 4.11 Data Format for 3000Ω Resistance Input

Excitation Current	Data Format			
	Engineering Units x 1	Engineering Units x 10	Scaled-for-PID	Proportional Counts (Default)
	0.1 Ω ⁽¹⁾	1.0 Ω ⁽¹⁾		
0.25 mA	0 to 30000	0 to 3000	0 to 16383	-32768 to 32767
1.0 mA	0 to 12000	0 to 1200	0 to 16383	-32768 to 32767

(1) When ohms are selected, the temperature-units selection (bit 8) is ignored.

The following table shows the data resolution provided by the 1746-NR8 for RTD input types using the various data formats. The table applies to both 0.25 and 1.0 mA excitation currents. The data resolution of the remaining RTDs vary with excitation current.

Table 4.12 Channel Data Word Resolution for RTDs

RTD Input Type	Data Format (Bits 4 and 5) ⁽¹⁾							
	Engineering Units x 1		Engineering Units x 10		Scaled-for-PID		Proportional Counts (Default)	
	°C	°F	°C	°F	°C	°F	°C	°F
100Ω Platinum 385	0.1°C/step	0.1°F/step	1°C/step	1°F/step	0.0641°C/step	0.1154°F/step	0.0160°C/step	0.0288°F/step
200Ω Platinum 385	0.1°C/step	0.1°F/step	1°C/step	1°F/step	0.0641°C/step	0.1154°F/step	0.0160°C/step	0.0288°F/step
100Ω Platinum 3916	0.1°C/step	0.1°F/step	1°C/step	1°F/step	0.0507°C/step	0.0912°F/step	0.0127°C/step	0.0228°F/step
200Ω Platinum 3916	0.1°C/step	0.1°F/step	1°C/step	1°F/step	0.0507°C/step	0.0912°F/step	0.012 °C/step	0.0228°F/step
10Ω Copper 426	0.1°C/step	0.1°F/step	1°C/step	1°F/step	0.0220°C/step	0.0396°F/step	0.0051°C/step	0.0099°F/step
120Ω Nickel 618 ⁽²⁾	0.1°C/step	0.1°F/step	1°C/step	1°F/step	0.0220°C/step	0.0396°F/step	0.0051°C/step	0.0099°F/step
120Ω Nickel 672	0.1°C/step	0.1°F/step	1°C/step	1°F/step	0.0208°C/step	0.0374°F/step	0.005 °C/step	0.0093°F/step

(1) When ohms are selected, the temperature-units selection (bit 8) is ignored. Analog input data is the same for either °C or °F selection.

(2) Actual value at 0°C is 100Ω per DIN standard.

Table 4.13 Channel Data Word Resolution for 500Ω Platinum (385)

Excitation Current	Data Format (Bits 4 and 5) ⁽¹⁾							
	Engineering Units x 1		Engineering Units x 10		Scaled-for-PID		Proportional Counts (Default)	
	°C	°F	°C	°F	°C	°F	°C	°F
0.25 mA	0.1°C/step	0.1°F/step	1°C/step	1°F/step	0.0641°C/step	0.1154°F/step	0.0160°C/step	0.0288°F/step
1.0 mA	0.1°C/step	0.1°F/step	1°C/step	1°F/step	0.0360°C/step	0.0648°F/step	0.0090°C/step	0.0162°F/step

(1)

Table 4.14 Channel Data Word Resolution for 1000Ω Platinum (385)

Excitation Current	Data Format (Bits 4 and 5) ⁽¹⁾							
	Engineering Units x 1		Engineering Units x 10		Scaled-for-PID		Proportional Counts (Default)	
	°C	°F	°C	°F	°C	°F	°C	°F
0.25 mA	0.1°C/step	0.1°F/step	1°C/step	1°F/step	0.0641°C/step	0.1154°F/step	0.0160°C/step	0.0288°F/step
1.0 mA	0.1°C/step	0.1°F/step	1°C/step	1°F/step	0.0153°C/step	0.0275°F/step	0.0038°C/step	0.0069°F/step

(1)

Table 4.15 Channel Data Word Resolution for 500Ω Platinum (3916)

Excitation Current	Data Format (Bits 4 and 5) ⁽¹⁾							
	Engineering Units x 1		Engineering Units x 10		Scaled-for-PID		Proportional Counts (Default)	
	°C	°F	°C	°F	°C	°F	°C	°F
0.25 mA	0.1°C/step	0.1°F/step	1°C/step	1°F/step	0.0507°C/step	0.0912°F/step	0.0127°C/step	0.0228°F/step
1.0 mA	0.1°C/step	0.1°F/step	1°C/step	1°F/step	0.0354°C/step	0.0637°F/step	0.0089°C/step	0.0159°F/step

(1)

Table 4.16 Channel Data Word Resolution for 1000Ω Platinum (3916)

Excitation Current	Data Format (Bits 4 and 5) ⁽¹⁾							
	Engineering Units x 1		Engineering Units x 10		Scaled-for-PID		Proportional Counts (Default)	
	°C	°F	°C	°F	°C	°F	°C	°F
0.25 mA	0.1°C/step	0.1°F/step	1°C/step	1°F/step	0.0507°C/step	0.0912°F/step	0.0127°C/step	0.0228°F/step
1.0 mA	0.1°C/step	0.1°F/step	1°C/step	1°F/step	0.0153°C/step	0.0275°F/step	0.0038°C/step	0.0104°F/step

(1)

Table 4.17 Channel Data Word Resolution for 604Ω Nickel Iron (518)

Excitation Current	Data Format (Bits 4 and 5) ⁽¹⁾							
	Engineering Units x 1		Engineering Units x 10		Scaled-for-PID		Proportional Counts (Default)	
	°C	°F	°C	°F	°C	°F	°C	°F
0.25 mA	0.1°C/step	0.1°F/step	1°C/step	1°F/step	0.0183°C/step	0.0330°F/step	0.0046°C/step	0.0082°F/step
1.0 mA	0.1°C/step	0.1°F/step	1°C/step	1°F/step	0.0232°C/step	0.0417°F/step	0.0058°C/step	0.0104°F/step

(1)

The following two tables show the data resolution provided by the 1746-NR8 for resistance input types using the various data formats.

Table 4.18 Channel Data Word Resolution for 150 Ω Resistance Input

Resistance Input Type	Data Format (Bits 4 and 5)			
	Engineering Units x 1	Engineering Units x 10	Scaled-for-PID	Proportional Counts (Default)
	Ohms	Ohms	Ohms	Ohms
150 Ω	0.01 Ω /step	0.1 Ω /step	0.0092 Ω /step	0.0023 Ω /step

Table 4.19 Channel Data Word Resolution for 500 Ω , 1000 Ω , and 3000 Ω Resistance Inputs

Resistance Input Type	Data Format (Bits 4 and 5)			
	Engineering Units x 1	Engineering Units x 10	Scaled-for-PID	Proportional Counts (Default)
	Ohms	Ohms	Ohms	Ohms
500 Ω	0.1 Ω /step	1 Ω /step	0.0305 Ω /step	0.0076 Ω /step
1000 Ω	0.1 Ω /step	1 Ω /step	0.0610 Ω /step	0.0153 Ω /step
3000 Ω	0.1 Ω /step	1 Ω /step	0.1831 Ω /step	0.0458 Ω /step

Broken Input Selection (Bits 6 and 7)

The next table shows the descriptions for bits 6 and 7. The broken input bit field lets you define the state of the channel data word when an open-circuit or short-circuit condition is detected for that channel.

An open-circuit condition occurs when the RTD or potentiometer or its extension wire is physically separated or opened. This can happen if the wire is cut or disconnected from the terminal block.

The short-circuit condition applies only to RTD input types. This can happen if the RTD or its signal wires are shorted together for any reason. The short-circuit condition does not apply to resistance ranges since they start at 0 ohms, which can be a short-circuit condition.

Table 4.20 Bit Descriptions for Broken Input Selection

Binary Value	Select	Description
00	Zero	Force the channel data word to 0 during an open-circuit condition or short-circuit condition.
01	Upscale	Force the channel data word value to its full scale value during an open-circuit or short-circuit condition. The full scale value is determined by the input type, data format, and scaling selected.
10	Downscale	Force the channel data word value to its low scale value during an open-circuit or short-circuit condition. The low scale value is determined by the input type, data format, and scaling selected.

Temperature Units Selection (Bit 8)

The following table shows the description for bit 8. The temperature units bit lets you select temperature engineering units in °C or °F for RTD input types. This bit field is only active for RTD input types. It is ignored when the resistance input type is selected.

Table 4.21 Bit Descriptions for Temperature Units Selection

Binary Value	Select	If you want to
0	°C	display the channel data word in °C.
1	°F	display the channel data word in °F.

Filter Frequency Selection (Bits 9 and 10)

The following table shows the descriptions for bits 9 and 10. The channel filter frequency bit field lets you select one of four filters available for a channel. The filter frequency affects the channel update time and noise rejection characteristics (refer to Chapter 3 for details).

Table 4.22 Bit Descriptions for Filter Frequency Selection

Binary Value	Select	Description
00	28 Hz	Provide both 50 Hz and 60 Hz AC line noise filtering. This setting increases the channel update time, but also increases the noise rejection.
01	50/60 Hz	Provide both 50 Hz and 60 Hz AC line noise filtering.
10	800 Hz	Provide 800 Hz AC line noise filtering.
11	6400 Hz	Provide 6400 Hz AC noise filtering. This setting decreases the noise rejection, but also decreases the channel update time.

Channel Enable Selection (Bit 11)

The next table shows the description for bit 11. You use the channel enable bit to enable a channel. The RTD module only scans those channels that are enabled. To optimize module operation and minimize throughput times, you should *disable unused channels* by setting the channel enable bit to zero.

When set (1), the channel enable bit is used by the module to read the configuration word information you have selected. While the enable bit is set, modification of the configuration word may lengthen the module update time for one cycle. If any change is made to the configuration word, the change must be reflected in the status word before new data is valid. (Refer to *Channel Status Checking* on page 4-19.)

While the channel enable bit is cleared (0), the channel data word and status word values are cleared. After the channel enable bit is set, the channel data word and status word remain cleared until the RTD module sets the channel status bit (bit 11) in the channel status word.

Table 4.23 Bit Descriptions for Channel Enable Selection

Binary Value	Select	If you want to
0	channel disable	disable a channel. Disabling a channel causes the channel data word and the channel status word to be cleared.
1	channel enable	enable a channel.

Excitation Current Selection (Bit 12)

The following table shows the description for bit 12. Use this bit to select the magnitude of the excitation current for each enabled channel. Choose from either 1.0 mA or 0.25 mA. This bit field is active for all inputs. A lower current reduces the error due to RTD self heating, but provides a lower signal-to-noise ratio. Refer to RTD vendor for recommendations. See Appendix A for general information.

Table 4.24 Bit Description for Excitation Current Selection

Binary Value	Select	Description
0	1.0 mA	Set the excitation current to 1.0 mA.
1	0.25 mA	Set the excitation current to 0.25 mA.

Calibration Disable (Bit 13)

The module can disable or enable periodic calibration by setting the calibration disable bit for channel 0. Setting this bit to 0 enables the periodic calibration, which occurs once every 5 minutes. Setting this bit to 1 disables the periodic calibration.

Lead Resistance Measurement Enable (Bits 14 and 15)

The module can disable lead resistance measurement, periodically measure the lead resistance, or measure the lead resistance on each acquisition for each one of the 8 channels. Setting a channel's lead resistance enable bits to 00 disables the lead resistance measurement. Setting a channel's lead resistance enable bits to 01 enables the periodic measurement of the lead resistance, which occurs once every five minutes. Setting a channel's lead resistance enable bits to 10 enables measurement of the lead resistance on each acquisition cycle.

Channel Data Word

The actual RTD or resistance input sensor values reside in I:e.0 through I:e.7 of the RTD module input image file. The data values present depend on the input type and data format you have selected in your configuration for the channel. When an input channel is disabled, its data word is reset (0).

Two conditions must be true for the value of the data word to be valid:

- The channel must be enabled (channel status bit = 1).
- There must be no channel errors or channel LED on (channel error bit = 0)

Figure 4.6 Module Input Image (Data Words)

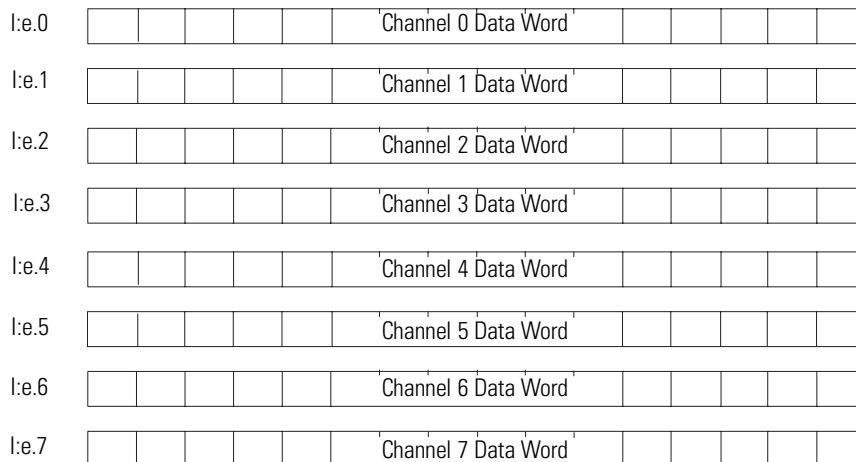

Channel Status Checking

The channel status word is a part of the RTD module’s input image. Input words 8 through 15 (Class 3 only) correspond to and contain the configuration status of channels 0 through 7 respectively. You can use the data provided in the status word to determine if the data word for any channel is valid per your configuration in O:e.0 through O:e.7 or O:e.23 (Class 3 only).

For example, whenever a channel is disabled (O:e.x/11 = 0), its corresponding status word shows all zeros. This condition tells you that input data contained in the data word for that channel is not valid and should be ignored.

Figure 4.7 Module Input Image (Status Word)

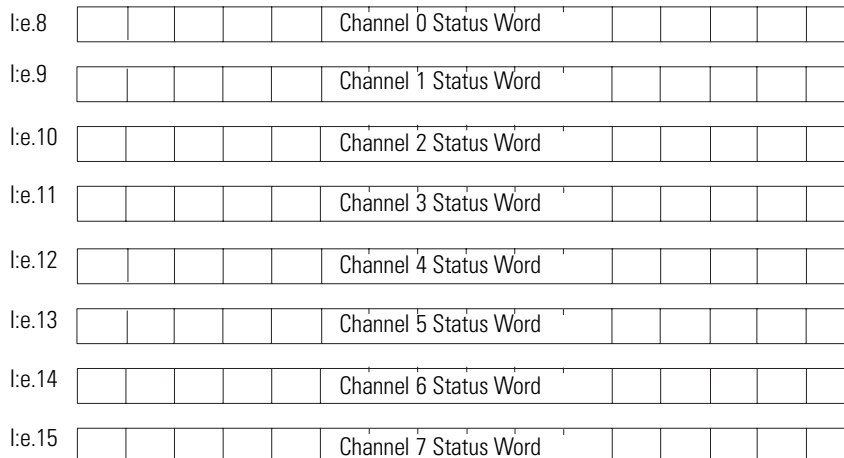

The channel status word can be analyzed bit by bit. Each bit's status (0 or 1) tells you how the input data from the RTD sensor or resistance device connected to a specific channel is translated for your application. The bit status also informs you of any error condition and can tell you what type error occurred.

A bit-by-bit examination of the status word is provided in the following table.

Table 4.25 Channel 0 through 7 Status Word (I.e.8 through I.e.15) - Bit Definitions

Bit(s)	Define	These bit settings														Indicate this				
		15	14	13	12	11	10	9	8	7	6	5	4	3	2		1	0		
0 through 3	Input type status													0	0	0	0	100Ω Pt RTD (385)		
															0	0	0	1	200Ω Pt RTD (385)	
																0	0	1	0	500Ω Pt RTD (385)
																0	0	1	1	1000Ω Pt RTD (385)
																0	1	0	0	100Ω Pt RTD (3916)
																0	1	0	1	200Ω Pt RTD (3916)
																0	1	1	0	500Ω Pt RTD (3916)
																0	1	1	1	1000Ω Pt RTD (3916)
																1	0	0	0	10Ω Cu RTD (426) ⁽¹⁾
																1	0	0	1	120Ω Ni RTD (618) ⁽²⁾
																1	0	1	0	120Ω Ni RTD (672)
																1	0	1	1	604Ω NiFe RTD (518)
																1	1	0	0	150Ω Resistance Input
																1	1	0	1	500Ω Resistance Input
														1	1	1	0	1000Ω Resistance Input		
														1	1	1	1	3000Ω Resistance Input		
4 through 5	Data format status												0	0				Engineering units x 1 ⁽³⁾		
													0	1				Engineering units x 10 ⁽⁴⁾		
													1	0				Scaled-for-PID		
													1	1				Proportional Counts		
6 through 7	Broken input status									0	0							Set to Zero		
										0	1							Set to Upscale		
										1	0							Set to Downscale		
										1	1							Not used		
8	Temperature units status								0									Degrees C ⁽⁵⁾		
									1									Degrees F ⁽⁵⁾		
9 through 10	Filter frequency status						0	0										28 Hz		
							0	1										50/60 Hz		
							1	0										800 Hz		
							1	1										6400 Hz		
11	Channel enable status					0												Channel Disabled		
						1												Channel Enabled		
12	Calibration Error				0													OK		
					1													Error		
13	Broken input			0														OK		
				1														Error		
14	Out-of-range error status		0															OK		
			1															Error		
15	Configuration Error	0																OK		
		1																Error		

(1) Actual value at 0°C is 9.042Ω per SAMA standard RC21-4-1966.
 (2) Actual value at 0°C is 100Ω per DIN standard.
 (3) Values are in 0.1 degree /step or 0.1Ω/step for all resistance input types, except 150Ω. For the 150Ω resistance input type, the values are in 0.01Ω/step.
 (4) Values are in 1 degree /step or 1Ω/step for all resistance input types, except 150Ω. For the 150Ω resistance input type, the values are in 0.1Ω/step.
 (5) This bit is cleared (0) when a resistance device, such as a potentiometer, is selected.

Explanations of the status conditions follow.

IMPORTANT

The status bits reflect the settings that were made in the configuration word. However, two conditions must be true if the status reflected is to be accurate:

- The channel must be enabled.
 - The channel must have processed any new configuration data.
-

Input Type Status (Bits 0 through 3)

The input type bit field indicates what type of input device you have configured for the channel. This field reflects the input type selected in bits 0 through 3 of the channel configuration word when the channel is enabled. If the channel is disabled, these bits are cleared (0).

Data Format Status (Bits 4 and 5)

The data format bit field indicates the data format you have defined for the channel. This field reflects the data type selected in bits 4 and 5 of the channel configuration word when the channel is enabled. If the channel is disabled, these bits are cleared (0).

Broken Input Status (Bits 6 and 7)

The broken input bit field indicates how you have defined the channel data to respond to an open-circuit or short-circuit condition. This field reflects the broken input type selected in bits 6 and 7 of the channel configuration word when the channel is enabled. If the channel is disabled, these bits are cleared (0).

Temperature Units Status (Bit 8)

The temperature units field indicates the state of the temperature units bit in the configuration word (bit 8). This feature is only active for RTD input types with the channel enabled. This bit is cleared (0) if the channel is disabled or if the input type is a resistance device such as potentiometer.

Channel Filter Frequency (Bits 9 and 10)

The channel filter frequency bit field reflects the filter frequency you selected in bits 9 and 10 of the configuration word when the channel is enabled. This feature is active for all input types. If the channel is disabled, these bits are cleared (0).

Channel Enable Status (Bit 11)

The channel enable status bit indicates whether the channel is enabled or disabled. This bit is set (1) when the channel enable bit is set in the configuration word (bit 11) and there is valid data in the channel's data word. The channel status bit is cleared (0) if the channel is disabled.

Calibration Error (Bit 12)

If a calibration error occurs this flag is set. A calibration error is a fatal error. It indicates that the module was not able to complete its on board calibration process. A calibration error could effect individual channels, but may get set on all channels at the same time if the ADC has a hardware fault.

Broken Input Error (Bit 13)

This bit is set (1) whenever an enabled channel detects a broken input condition. A broken input error is declared for the following reasons:

- *Open-circuit* - excitation current is less than 50% of the selected current.
- *Short-circuit* - calculated lead wire compensated RTD resistance is less than 3 ohms.

The open-circuit error is active for all RTD and resistance inputs, while the short-circuit error is valid only for RTD inputs. If a broken input is detected, the module sends either zero, upscale, or downscale data to the channel data word for that channel, depending on your channel configuration bits 6 and 7.

A broken input error takes precedence over an out-of-range error states. There is not an out-of-range error when an open-circuit or short circuit is detected.

This bit is cleared if the channel is disabled or if the channel operation is normal.

Out-Of-Range Error (Bit 14)

This bit is set (1) whenever a configured channel detects an over-range condition for the input channel data, regardless of input type. This bit is also set (1) whenever the module detects an under-range condition when the input type is an RTD. An out-of-range error is declared for either of the following conditions:

- *Over-range* - The RTD temperature is greater than the maximum allowed (default or user-set) temperature or the resistance input type is greater than the maximum allowed (default or user-set) resistance. When this occurs, the channel data word is set to its maximum value.
- *Under-range* - The RTD temperature is less than the minimum allowed (default or user-set) temperature. When this occurs, the channel data word is set to its minimum value.

IMPORTANT

There is no under-range error for a direct resistance input (default scaling).

This bit is cleared (0) for the following conditions:

- Channel is disabled.
- Channel operation is normal, the out-of-range condition clears
- Broken input error bit (bit 13) is set (1).

Configuration Error (Bit 15)

This bit is set (1) whenever an enabled and configured channel detects that the channel configuration word is not valid. A configuration word is not valid for any of the following reasons:

- Input type is a 10 Ω Copper RTD and the excitation current is set for 0.25 mA, which is not allowed.
- Lead R Enable bits 14 and 15 are set to 11, which is invalid.
- Broken Input select bits 6 and 7 are set to 11, which is invalid.
- Data format bits are set to 11, and the lower limit user-set scale is equal to the upper limit user-set scale and not equal to 0.

All other status bits reflect the settings from the configuration word (even those settings that may be in error). However, bit 15 is cleared if the channel is disabled or if channel operation is normal.

Ladder Programming Examples

Earlier chapters explained how the configuration word defines the way a channel operates. This chapter shows the programming required to enter the configuration word into the processor memory. It also provides you with segments of ladder logic specific to unique situations that might apply to your programming requirements. The example segments include:

- initial programming of the configuration word
- dynamic programming of the configuration word
- verifying channel configuration changes
- interfacing the RTD module to a PID instruction
- using proportional counts scaling (example)
- monitoring channel status bits
- invoking autocalibration

Device Configuration

The following illustration is used for clarification of the ensuing ladder logic examples and is not intended to represent an RTD application.

IMPORTANT

Chapter 7 shows a typical application for the RTD module.

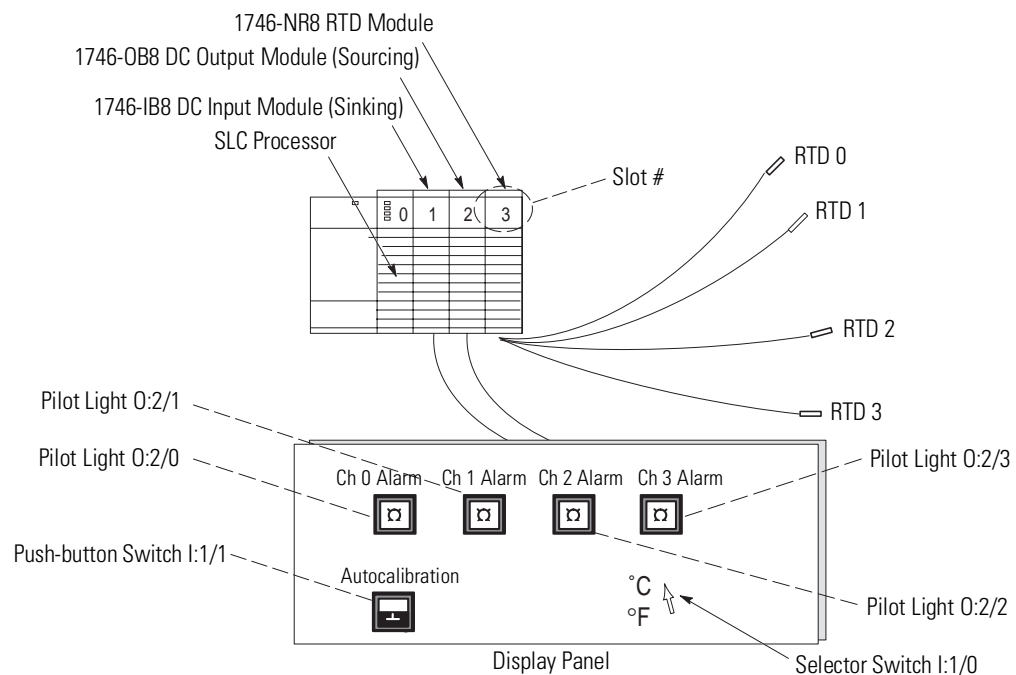

Initial Programming

To enter data into the channel configuration word (O:e.0 through O:e.7) when the channel is disabled (bit 11 = 0), follow the example below.

Refer to page 4-5 for specific configuration details.

Example - Configure eight channels of a RTD module residing in slot 3 of a 1746 chassis. Configure the first four channels with one set of parameters, and the last four channels with a different set of parameters.

Figure 5.1 Configuration Word Setup for Channels 0 through 3

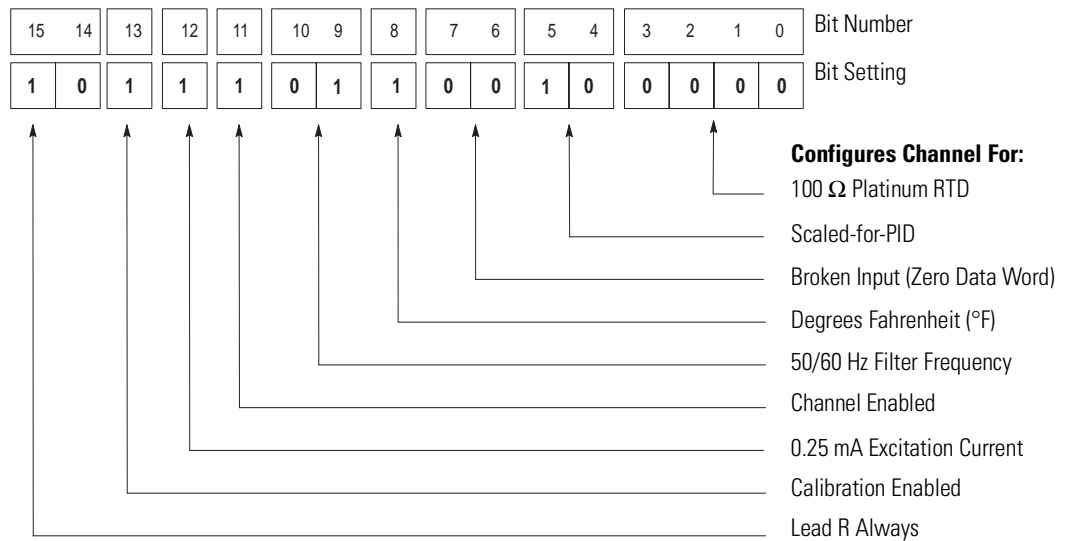
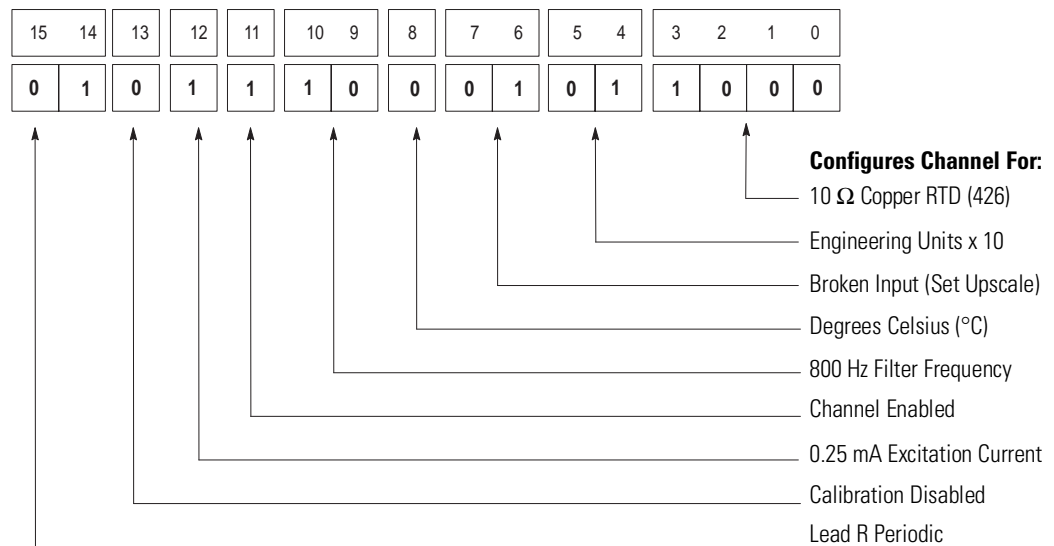
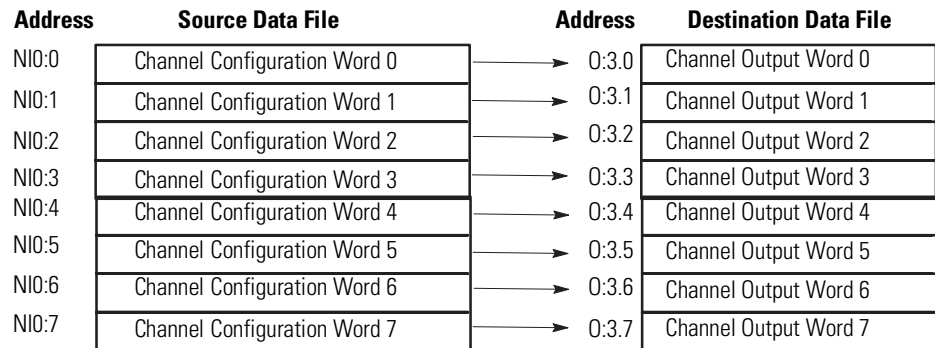

Figure 5.2 Configuration Word Setup for Channels 4 Through 7



This example transfers configuration data and sets the channel enable bits of all eight channels with a single file copy instruction. The file copy instruction copies 8 data words from an integer file you create in the SLC’s memory, to the RTD module’s channel configuration words. This procedure is described below.

Figure 5.3 Copy File Data Flow



Procedure

1. Using the memory map function to create a data file, create integer file N10. Integer file N10 should contain eight elements (N10:0 through N10:7).
2. Using the RSLogix 500 data monitor function, enter the configuration parameters for all eight RTD channels into a source integer data file N10. Refer to the Configuration Word Setup illustration for the bit values. See Appendix B for a channel configuration worksheet.

Bit	15	14	13	12	11	10	9	8	7	6	5	4	3	2	1	0
N10:0	1	0	1	1	1	0	1	1	0	0	1	0	0	0	0	0
N10:1	1	0	1	1	1	0	1	1	0	0	1	0	0	0	0	0
N10:2	1	0	1	1	1	0	1	1	0	0	1	0	0	0	0	0
N10:3	1	0	1	1	1	0	1	1	0	0	1	0	0	0	0	0
N10:4	0	1	0	1	1	1	0	0	0	1	0	1	1	0	0	0
N10:5	0	1	0	1	1	1	0	0	0	1	0	1	1	0	0	0
N10:6	0	1	0	1	1	1	0	0	0	1	0	1	1	0	0	0
N10:7	0	1	0	1	1	1	0	0	0	1	0	1	1	0	0	0

3. Use the copy file instruction (COP) to copy the contents of integer file N10 to the eight consecutive output words of the RTD module beginning with O:3.0. To do this, program a rung as shown below. All elements are copied from the specified source file to the destination during the first scan following power up.

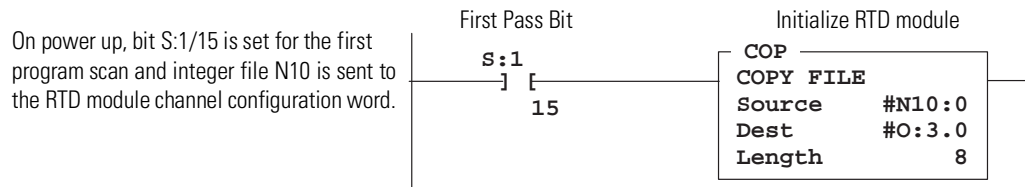

Dynamic Programming

The ladder below explains how to change data in the channel configuration word when the channel is currently enabled.

Example - Execute a dynamic configuration change to channel 2 of the RTD module located in slot 3 of a 1746 chassis. Change from monitoring the temperature in °F to monitoring in °C.

Figure 5.4 Program to Change Configuration Word Data

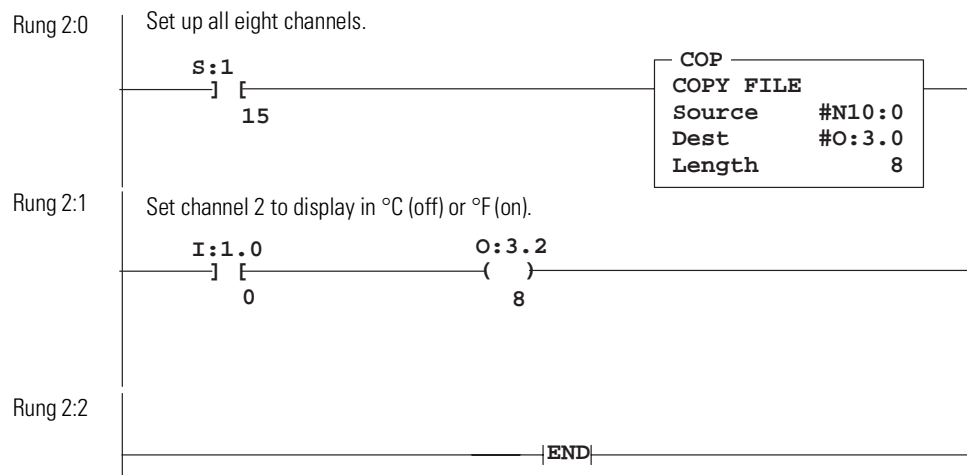

Verifying Channel Configuration Changes

When executing a dynamic channel configuration change, there is always a delay from the time the ladder program makes the change to the time the RTD module gives you a data word using that new configuration information. Therefore, it is very important to verify that a dynamic channel configuration change took effect in the RTD module, particularly if the channel being dynamically configured is used for control.

Example - Execute a dynamic configuration change to channel 2 of the RTD module located in slot 3 of a 1746 chassis and set an internal “data valid” bit when the new configuration has taken effect.

Figure 5.5 Program to Verify Configuration Word Data Changes

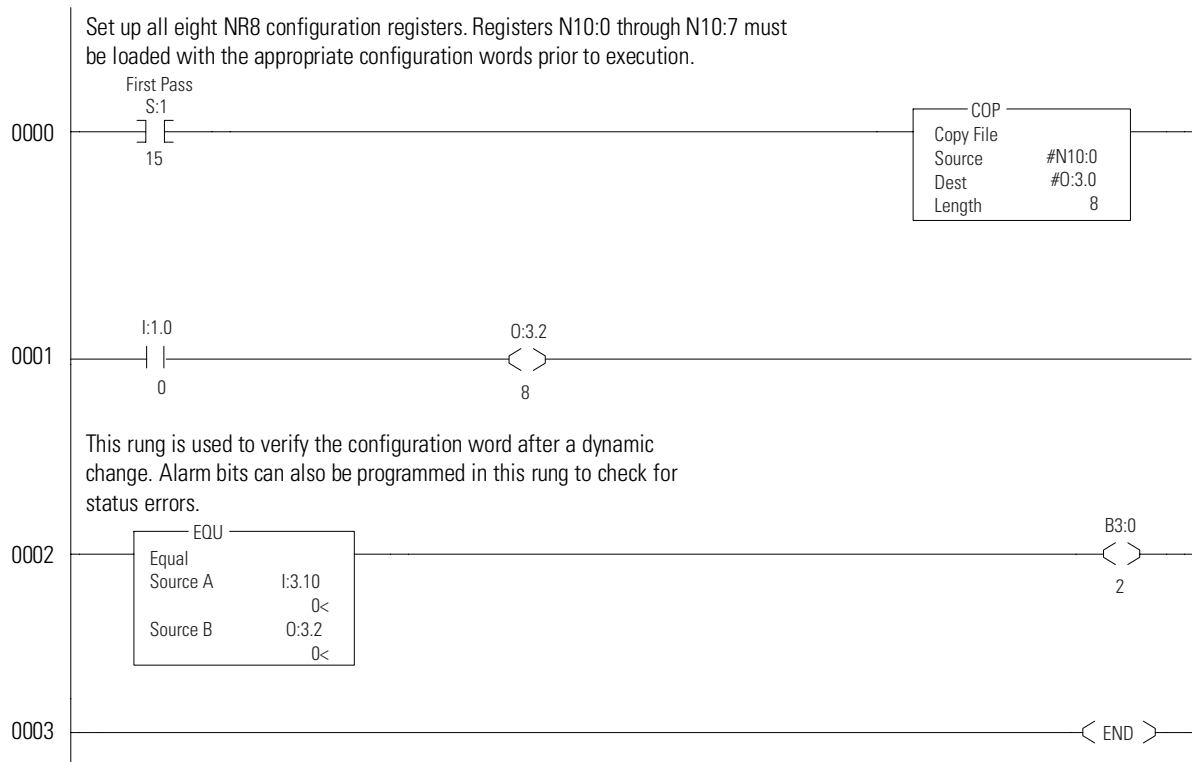

Interfacing to the PID Instruction

The RTD module was designed to interface directly to the SLC 5/02, SLC 5/03, SLC 5/04 and SLC 5/05 PID instruction without the need for an intermediate scale operation. Use RTD channel data as the process variable in the PID instruction.

To program this application, proceed as follows:

1. Select 100 Ω Platinum RTD, $\alpha= 0.003916$, as the input type by setting bit 0 = 0, bit 1 = 0, bit 2 = 1 and bit 3 = 0 in the configuration word.
2. Select scaled-for-PID as the data type by setting bit 4 = 0 and bit 5 = 1 in the configuration word.

ATTENTION



When using the module's scaled-for-PID data format with the SLC PID function, ensure that the PID instruction parameters *Maximum Scaled S_{max}* (word 7) and *Minimum Scaled S_{min}* (word 8) match the module's minimum and maximum scaled range, in engineering units, (e.g. -200°C to +850°C) for each channel. This allows you to accurately enter the setpoint in engineering units (°C, °F).

Figure 5.6 Programming for PID Application

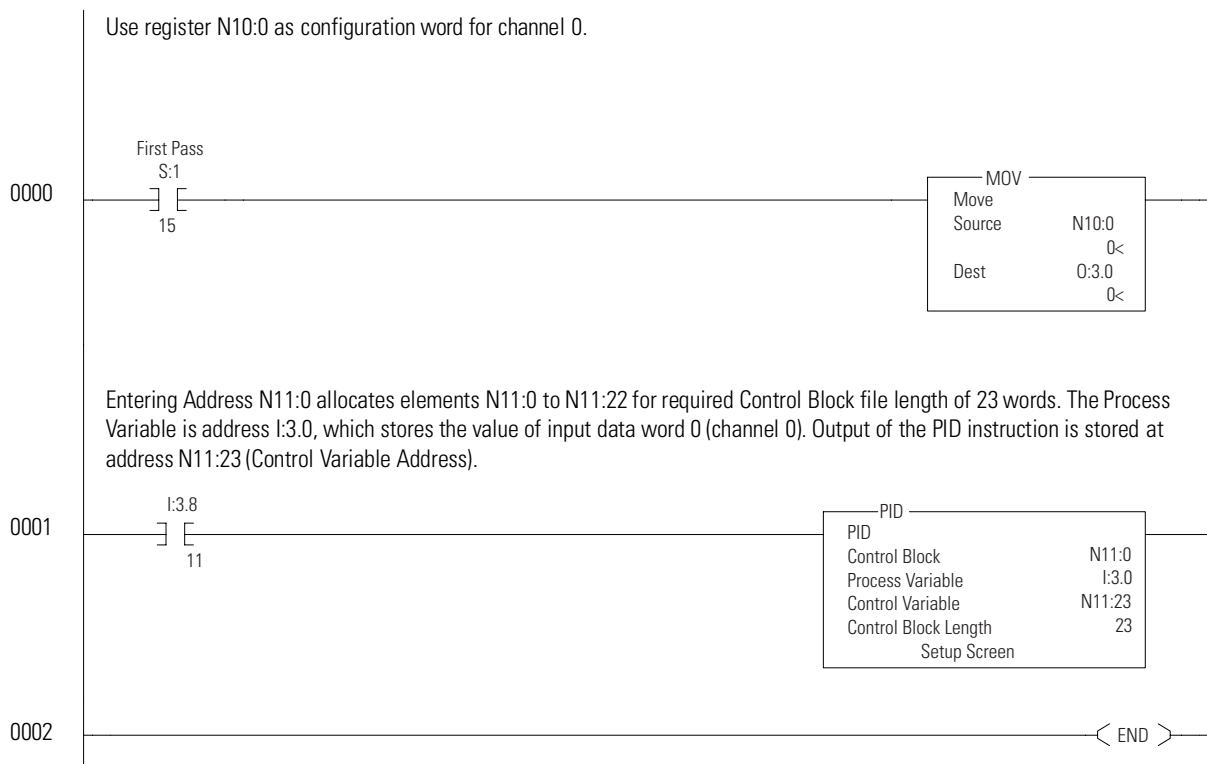

Using the Proportional Counts Data Format with the User-set Scaling (Class 3)

The RTD module can be set up to return data to the user program that is specific to the application. Assume that the user controls the line speed of a conveyor using a 1000Ω potentiometer connected to channel 0 of the RTD module. The line speed will vary between 3 feet/minute when the potentiometer is at 0Ω and 50 feet/minute when the potentiometer is at 1000Ω.

Example - Configure the RTD module in Class 3 operation to return a value between 3 and 50 in the data word for channel 0. Proceed as follows:

1. Set bits 0 through 3 of configuration word 0 to 1110 to select the 1000Ω potentiometer input type.
2. Set bits 4 and 5 of configuration word 0 to 11 to select proportional counts data format.
3. Enter 3 as the low range into N10:8.
4. Enter 50 as the high range into N10:9.

Figure 5.7 Programming for PID Applications)

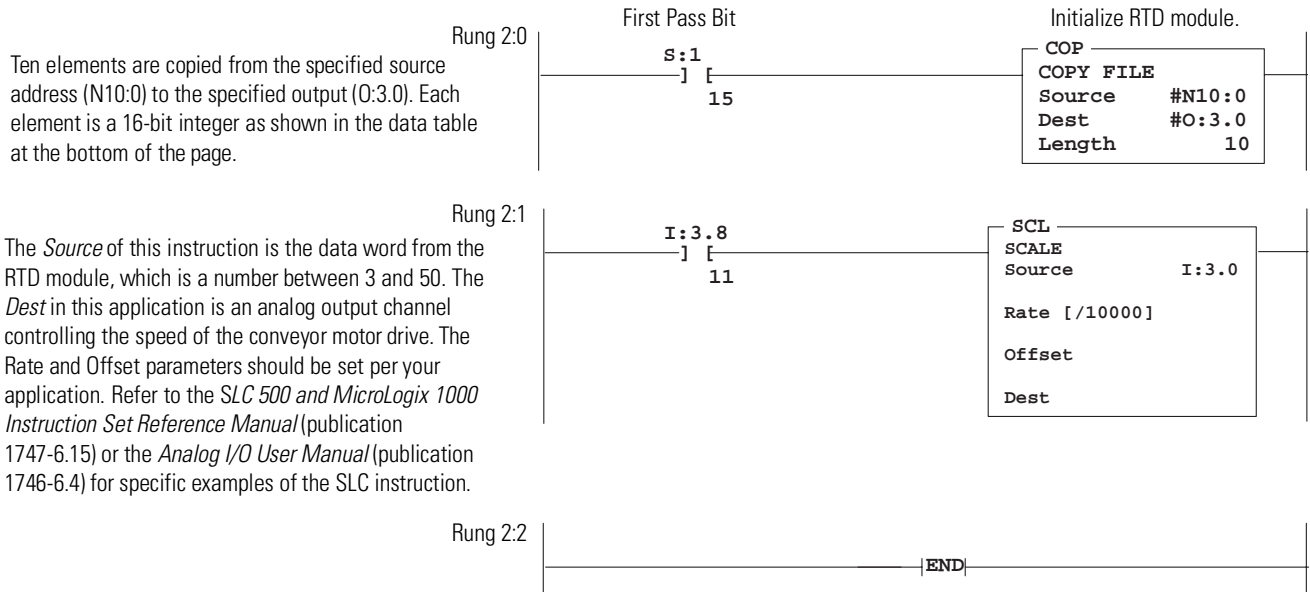

Ten elements are copied from the specified source address (N10:0) to the specified output (O:3.0). Each element is a 16-bit integer as shown in the data table at the bottom of the page.

The *Source* of this instruction is the data word from the RTD module, which is a number between 3 and 50. The *Dest* in this application is an analog output channel controlling the speed of the conveyor motor drive. The Rate and Offset parameters should be set per your application. Refer to the *SLC 500 and MicroLogix 1000 Instruction Set Reference Manual* (publication 1747-6.15) or the *Analog I/O User Manual* (publication 1746-6.4) for specific examples of the SCL instruction.

For Class 3 operation registers N10:8 and N10:9 can be used to scale channel 0 for a minimum conveyor speed of 3 ft./minute and a maximum conveyor speed of 50 ft./minute

Table 5.1 Data Table (Class 3)

Address	15	14	13	12	11	10	9	8	7	6	5	4	3	2	1	0
N10:0	0	0	1	0	1	0	0	0	0	0	1	1	1	1	1	0
N10:1	0	0	0	0	0	0	0	0	0	0	0	0	0	0	0	0
N10:2	0	0	0	0	0	0	0	0	0	0	0	0	0	0	0	0
N10:3	0	0	0	0	0	0	0	0	0	0	0	0	0	0	0	0
N10:4	0	0	0	0	0	0	0	0	0	0	0	0	0	0	0	0
N10:5	0	0	0	0	0	0	0	0	0	0	0	0	0	0	0	0
N10:6	0	0	0	0	0	0	0	0	0	0	0	0	0	0	0	0
N10:7	0	0	0	0	0	0	0	0	0	0	0	0	0	0	0	0
N10:8	0	0	0	0	0	0	0	0	0	0	0	0	0	0	1	1
N10:9	0	0	0	0	0	0	0	0	0	0	1	1	0	0	1	0

Monitoring Channel Status Bits

The following illustration shows how to monitor the open- and short-circuit error bits of each channel and set an alarm in the processor if one of the RTDs or resistance-input devices (such as a potentiometer) opens or shorts. An open-circuit error can occur if the RTD or resistance-input device breaks or one of the RTD or resistance-input device wires get cut or disconnected from the terminal block. A short-circuit condition applies only to RTD input.

Figure 5.8 Programming to Monitor Channel Status

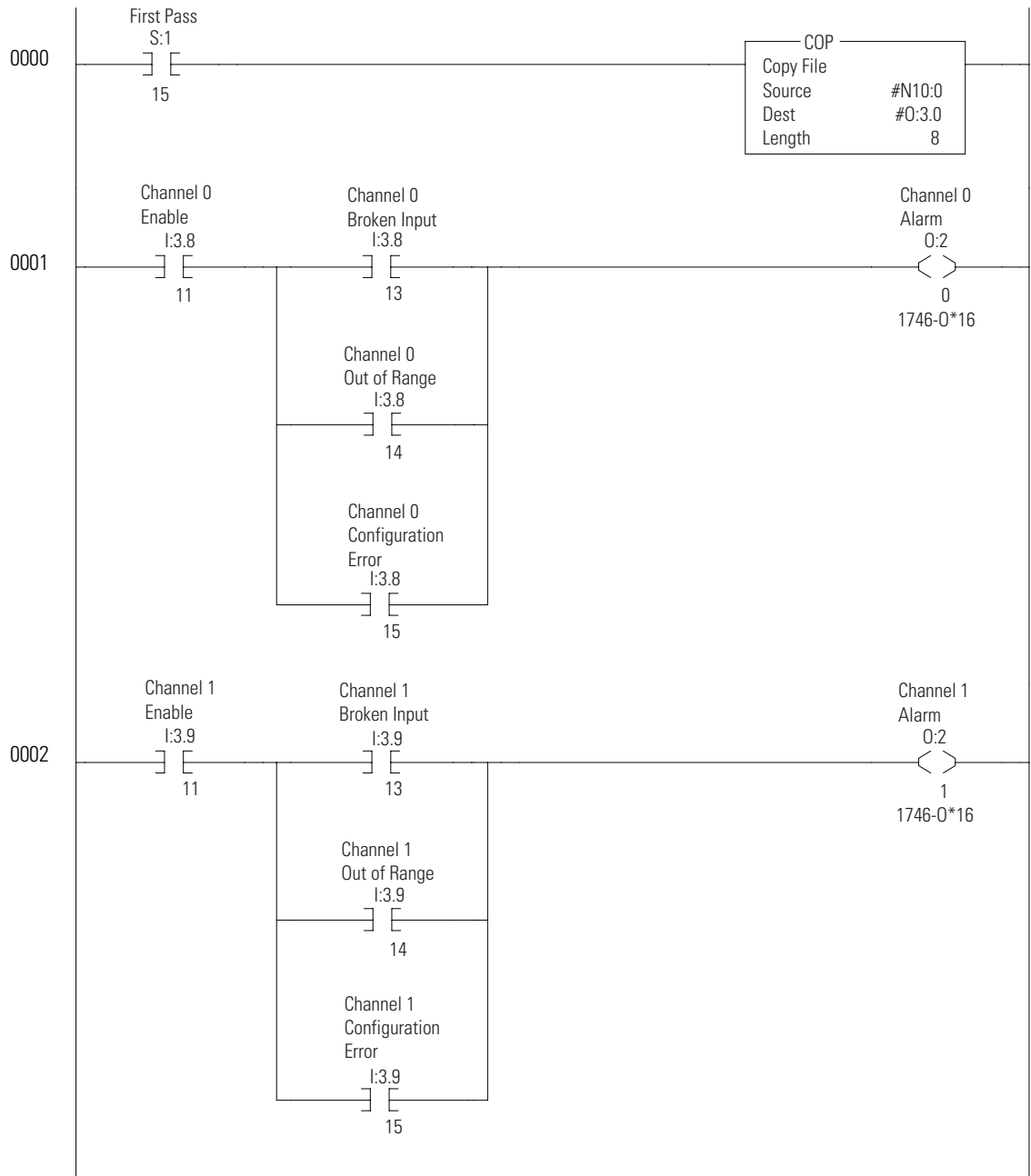

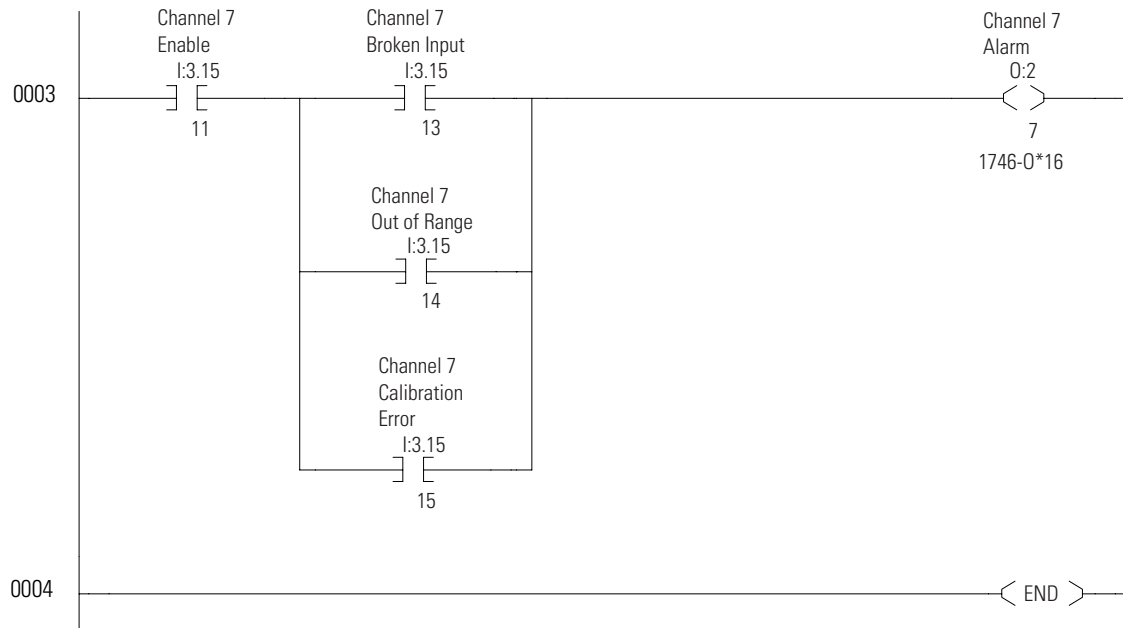

Invoking Autocalibration

Autocalibration occurs whenever:

- power is provided to the module
- a change is made to its input type, filter frequency, or excitation current
- an operating channel is disabled and re-enabled using its enable bit
- the periodic calibration bit is toggled from 1 (disable) to 0 (enable) and back to 1 (disable)

Referring to the following ladder, you can command your module to perform an autocalibration cycle by toggling the periodic calibration bit (bit 15).

To maintain system accuracy we recommend that you periodically perform an autocalibration cycle, for example:

- whenever an event occurs that greatly changes the internal temperature of the control cabinet, such as opening or closing its door
- at a convenient time when the system is not making product, such as during a shift change.

ATTENTION



Several channel cycles are required to perform an autocalibration and it is important to remember that during autocalibration the module is not converting input data.

Example - Command the RTD module to perform an autocalibration of channel 0. The RTD module is in slot 3. This example assumes that the periodic calibration bit (bit 15) is in the disabled state (set to 1).

Programming to Invoke Autocalibration

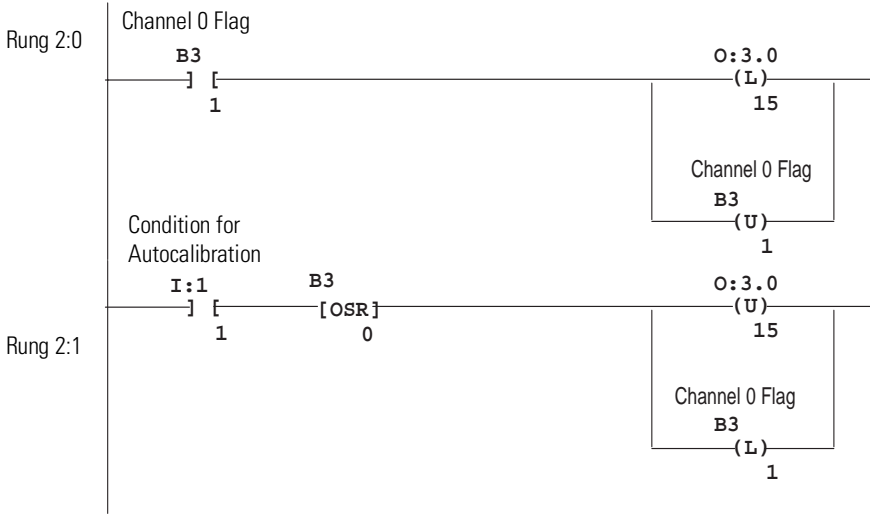

Module Diagnostics and Troubleshooting

This chapter describes troubleshooting using the channel status LEDs as well as the module status LED. A troubleshooting flowchart is shown on page 6-6. It explains the types of conditions that might cause an error to be reported and gives suggestions on how to resolve the problem. Major topics include:

- module operation vs. channel operation
- power-up diagnostics
- channel diagnostics
- LED indicators
- troubleshooting flowchart
- replacement parts
- contacting Allen-Bradley

Module Operation vs. Channel Operation

The RTD module performs operations at two levels:

- module-level operations
- channel-level operations

Module-level operations include functions such as power-up configuration and communication with the SLC processor.

Channel-level operations describe channel-related functions, such as data conversion and open-circuit or short-circuit (RTDs only) detection.

Internal diagnostics are performed at both levels of operation and any error conditions detected are immediately indicated by the module's LEDs and status to the SLC processor.

Power-Up Diagnostics

At module power-up, a series of internal diagnostic self-tests is performed. The module status LED remains off during power-up. The channel LEDs are turned on until the self test has finished. If any diagnostic test fails, the module enters the module error state. If all tests pass, the module status LED is turned on and the channel status LED is turned on for the respective enabled channel. The module continuously scans all enabled channels and communicates with the SLC processor. During power-up, the RTD module does not communicate with the processor.

Channel Diagnostics

When a channel is enabled (bit 11 = 1), a diagnostic check is performed to see that the channel has been properly configured. In addition, the channel is tested for out-of-range, open-circuit, and short-circuit faults on every scan.

A failure of any channel diagnostic test causes the faulted channel status LED to blink. All channel faults are indicated in bits 13 through 15 of the channel's status word. Channel faults are self-clearing (bits 13 and 14 of status word). Bit 15 is not cleared until the correct change is made to the channel configuration. The channel LED stops blinking and resumes steady illumination when the fault conditions are corrected.

IMPORTANT

If you clear (0) a channel enable bit (11), all channel status information (including error information) is reset (0).

LED Indicators

The RTD module has nine LEDs. Eight of these are channel status LEDs numbered to correspond to each of the RTD/resistance input channels and one is a module status LED.

Figure 6.1 LED Display

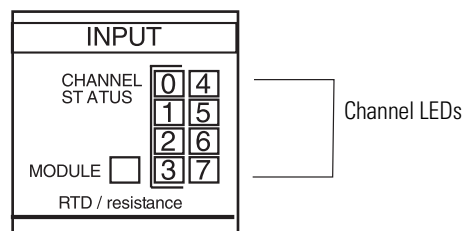

The following tables explain the function of the channel status LEDs while the module status LED is turned on.

Table 6.1 Module Status Description

If Module Status LED is:	Indicated Condition:	Corrective Action:
ON	Proper Operation	No action required.
Off or Flashing	Module Fault	Cycle power. If condition persists, replace the module or call your local distributor or Rockwell Automation for assistance.

Table 6.2 Channel Status Description

LED	Power-up ⁽¹⁾	Module Operation (No Error) ⁽²⁾	Module Error	Channel Error
Ch 0-7 Status	On	On/Off	Off ⁽³⁾	Flashes
Mod. Status	Off	On	Flashes/Off	On

(1) Module is disabled during powerup.

(2) Channel status LED is On if the respective channel is enabled and Off if the channel is disabled.

(3) Error if channel is enabled.

Error Codes

I/O error codes are reported in word S:6 of the SLC processor status file. The format for the error codes in the status word (S:6) is shown in the illustration below. The characters denoted as *XX* in the illustration below represent the slot number (Hex) for the module. The characters denoted as *YY* represent the 2-digit hex code for the fault condition.

The error codes applicable to the RTD Module range from 50H to 5AH. Some of these are non-recoverable errors. For a description of the error codes, refer to *SLC 500 and MicroLogix 1000 Instruction Set Reference Manual*, publication 1747-6.15.

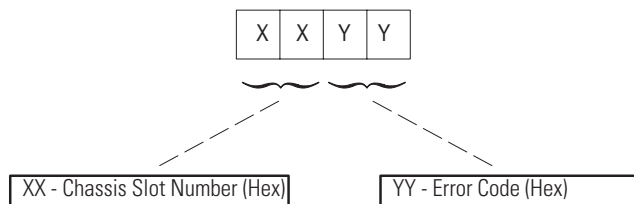

Channel Status LEDs (Green)

The channel LED is used to indicate channel status and related error information contained in the channel status word. This includes conditions such as:

- normal operation
- channel-related configuration errors
- broken input circuit errors such as open- or short-circuit (RTDs only)
- out-of-range errors

All channel errors are recoverable errors and after corrective action, normal operation resumes.

Invalid Channel Configuration

Whenever a channel's configuration word is improperly defined, the channel LED blinks and bit 15 of the channel status word is set. Configuration errors occur for the following invalid combinations:

- Input type is a 10 Ω Copper RTD and the excitation current is set for 0.25 mA, which is not allowed.
- Lead R Enable bits 14 and 15 are set to 11, which is invalid.
- Broken Input select bits 6 and 7 are set to 11, which is invalid.
- Data format bits are set to 11, and the lower limit user-set scale is equal to the upper limit user-set scale and not equal to 0.

Open- and Short-Circuit Detection

An open- or short-circuit test is performed on all enabled channels on each scan. Whenever an open-circuit or short-circuit condition occurs (see possible causes listed below), the channel LED blinks and bit 13 of the channel status word is set.

Possible causes of an open or short circuit include:

- The RTD or potentiometer may be broken.
- An RTD or potentiometer wire may be loose or cut.
- The RTD or potentiometer may not have been installed on the configured channel.
- The RTD may be internally shorted.
- The RTD may be installed incorrectly.
- Wrong RTD used for type/configuration selected.

If an open- or short-circuit is detected, the channel data word reflects input data as defined by the broken input configuration bits (6 and 7) in the channel configuration word.

Out-Of-Range Detection

Whenever the data received at the channel data word is out of the defined operating range, an over-range or under-range error is indicated and bit 14 of the channel status word is set.

IMPORTANT

There is no under-range error for a direct resistance input (default scaling).

For a review of the temperature range or resistance range limitations for your input device, refer to the temperature ranges provided in Chapter 5 or the user-specified range in configuration words 8 through 23 if proportional counts is used.

Possible causes of an out-of-range condition include:

- The temperature is too hot or too cold for the RTD being used.
- Wrong RTD used for type/configuration selected.
- Bad potentiometer or RTD.
- Signal input from either potentiometer or RTD is beyond the user-set scaling range.

Module Status LED (Green)

The module status LED is used to indicate module-related diagnostic or operating errors. These non-recoverable errors may be detected at power-up or during module operation. Once in a module error state, the RTD module no longer communicates with the SLC processor. Channels are disabled and data words are cleared (0).

Failure of any diagnostic test places the module in a non-recoverable state. To exit this state, cycle power. If the power cycle does not work, then call your local distributor or Rockwell Automation for assistance.

Figure 6.2 Troubleshooting Flowchart

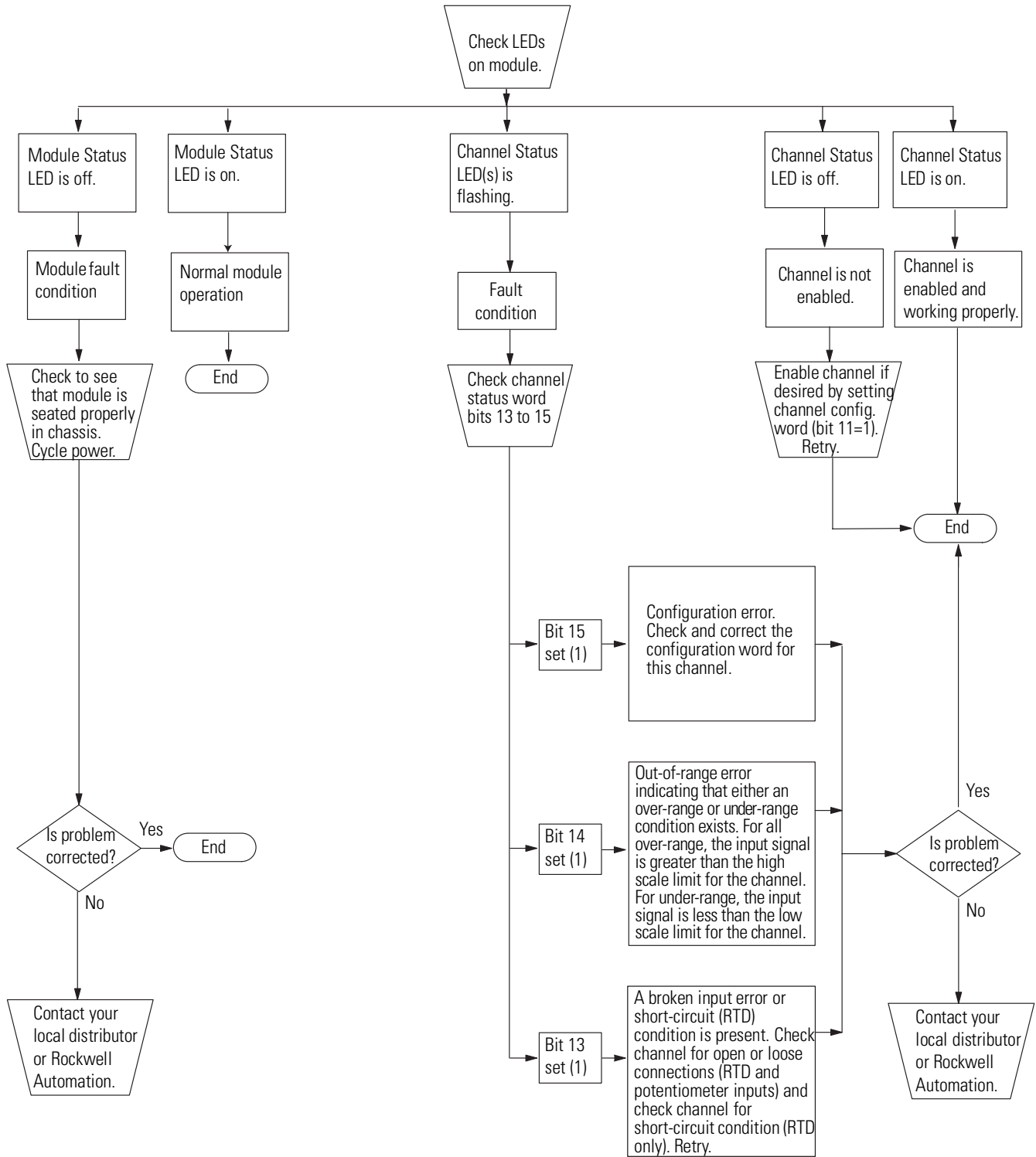

Replacement Parts

The RTD module has the following replaceable parts:

Table 6.3 Parts List

Part	Part Number
Replacement Terminal Block	1746-RT35
Replacement Terminal Cover	1746-R13 Series C
1746-NR8 User Manual	1746-UM003A-EN-P

Contacting Rockwell Automation

If you need to contact Rockwell Automation for assistance, please have the following information available when you call:

- a clear statement of the problem including a description of what the system is actually doing. Note and record the LED states; also, note input and output image words for the RTD module.
- a list of things you have already tried to remedy the problem
- processor type, 1746-NR8 series letter, and firmware (FRN) number. See label on left side of processor.
- hardware types in the system including I/O modules and chassis
- fault code if the SLC processor is faulted

Application Examples

This chapter provides two application examples to help you use the RTD input module. They are defined as a:

- basic example
- supplementary example

The basic example builds on the configuration word programming provided in Chapter 5 to set up one channel for operation. The module operates in Class 1 mode for this sample. This setup is then used in a typical application to display temperature.

The supplementary example demonstrates how to perform a dynamic configuration of all eight channels. The example sets up an application that allows you to manually select whether the displayed RTD input data for any channel is expressed in °C or °F. The module operates in Class 3 operation in order to support the scaling and status.

Basic Example

The following illustration indicates the temperature of a bath on an LED display. The display requires binary coded decimal (BCD) data, so the program must convert the temperature reading from the RTD module to BCD before sending it to the display. This application displays the temperature in °F.

Figure 7.1 Device Configuration

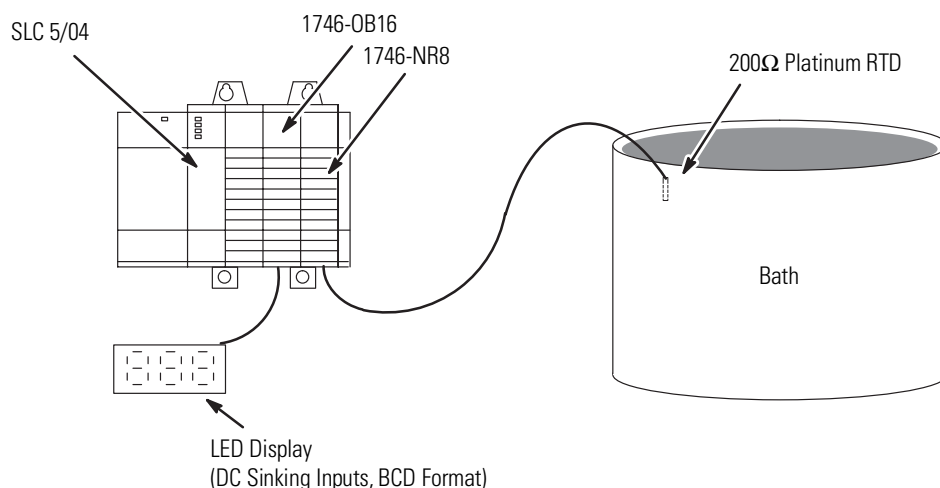

Channel Configuration

Configure the RTD channel with the following setup:

- 200Ω Platinum RTD
- °F in whole degrees
- zero data word in the event of an open or short circuit
- 28 Hz input filter
- 1.0 mA excitation current

**Table 7.1 Channel Configuration Worksheet
(With Settings Established for Channel 0)**

Bit Definitions:						
Bits 0 through 3	Input Type Select	0000 = 100 Ω Pt. (385) 0001 = 200 Ω Pt. (385) 0010 = 500 Ω Pt. (385) 0011 = 1000 Ω Pt. (385) 0100 = 100 Ω Pt. (3916) 0101 = 200 Ω Pt. (3916)	0110 = 500 Ω Pt. (3916) 0111 = 1000 Ω Pt. (3916) 1000 = 10 Ω Cu (426) ⁽¹⁾ 1001 = 120 Ω Ni (618) ⁽²⁾ 1010 = 120 Ω Ni (672) 1011 = 604 Ω Ni-Fe (518)	1100 = 150 Ω Potentiometer 1101 = 500 Ω Potentiometer 1110 = 1000 Ω Potentiometer 1111 = 3000 Ω Potentiometer		
Bits 4 and 5	Data Format Select	00 = engineering units, x1 ⁽³⁾ 01 = engineering units, x10 ⁽⁴⁾		10 = scaled-for-PID (0 to 16383) 11 = proportional counts (-32768 to +32767)		
Bits 6 and 7	Broken Input Select	00 = zero	01 = upscale	10 = downscale	11 = Invalid	
Bit 8	Temperature Units Select	0 = degrees Celsius	1 = degrees Fahrenheit			
Bits 9 and 10	Filter Frequency Select	00 = 28 Hz	01 = 50/60 Hz	10 = 800 Hz	11 = 6400 Hz	
Bit 11	Channel Enable	0 = channel disabled	1 = channel enabled			
Bit 12	Excitation Current Select	0 = 1.0 mA	1 = 0.25 mA			
Bit 13	Cal. Disable	0 = enable	1 = disable			
Bits 14 and 15	Lead R. Disable	00 = disable	01 = periodic	10 = always		

(1) Actual value at °C is 9.042 Ω per SAMA standard RC21-4-1966.

(2) Actual value at 0°C is 100 Ω per DIN standard.

(3) Values are in 0.1° /step or 0.1 Ω /step for all resistance input types, except 150 Ω . For the 150 Ω resistance input type, the values are in 0.01 Ω /step.

(4) Values are in 1° /step or 1 Ω /step for all resistance input types, except 150 Ω . For the 150 Ω resistance input type, the values are in 0.1 Ω /step.

Program Listing

Since a 7-segment LED display is used to display temperature, the temperature data must be converted to BCD. The 16-bit data word representing the temperature value is converted into BCD values by the program shown in the following illustration.

Figure 7.2 Program to Convert °F to BCD

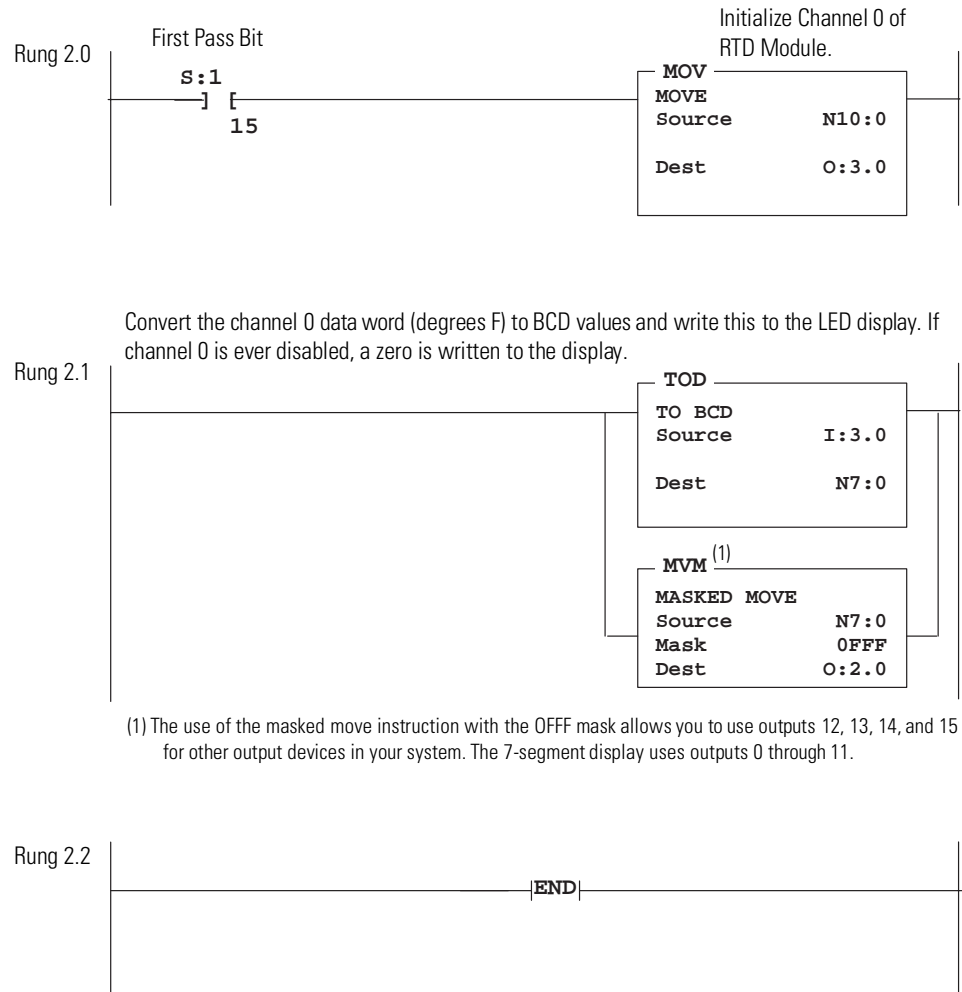

Convert the channel 0 data word (degrees F) to BCD values and write this to the LED display. If channel 0 is ever disabled, a zero is written to the display.

(1) The use of the masked move instruction with the 0FFF mask allows you to use outputs 12, 13, 14, and 15 for other output devices in your system. The 7-segment display uses outputs 0 through 11.

Table 7.2 Data Table

address	15	data	0	address	15	data	0
N10:0	0000	1001	0001 0001				

Supplementary Example

Application Setup (Eight Channels °C or °F)

The following illustration shows how to display the temperature of several different RTDs at one annunciator panel. A selector switch (I:2/0) allows the operator to choose between displaying data in °C and °F. Each of the displays is a 4-digit, 7-segment LED display with the last digit representing tenths of a degree. The displays have dc-sinking inputs and use a BCD data format.

Figure 7.3 Device Configuration for Displaying Many RTD Inputs

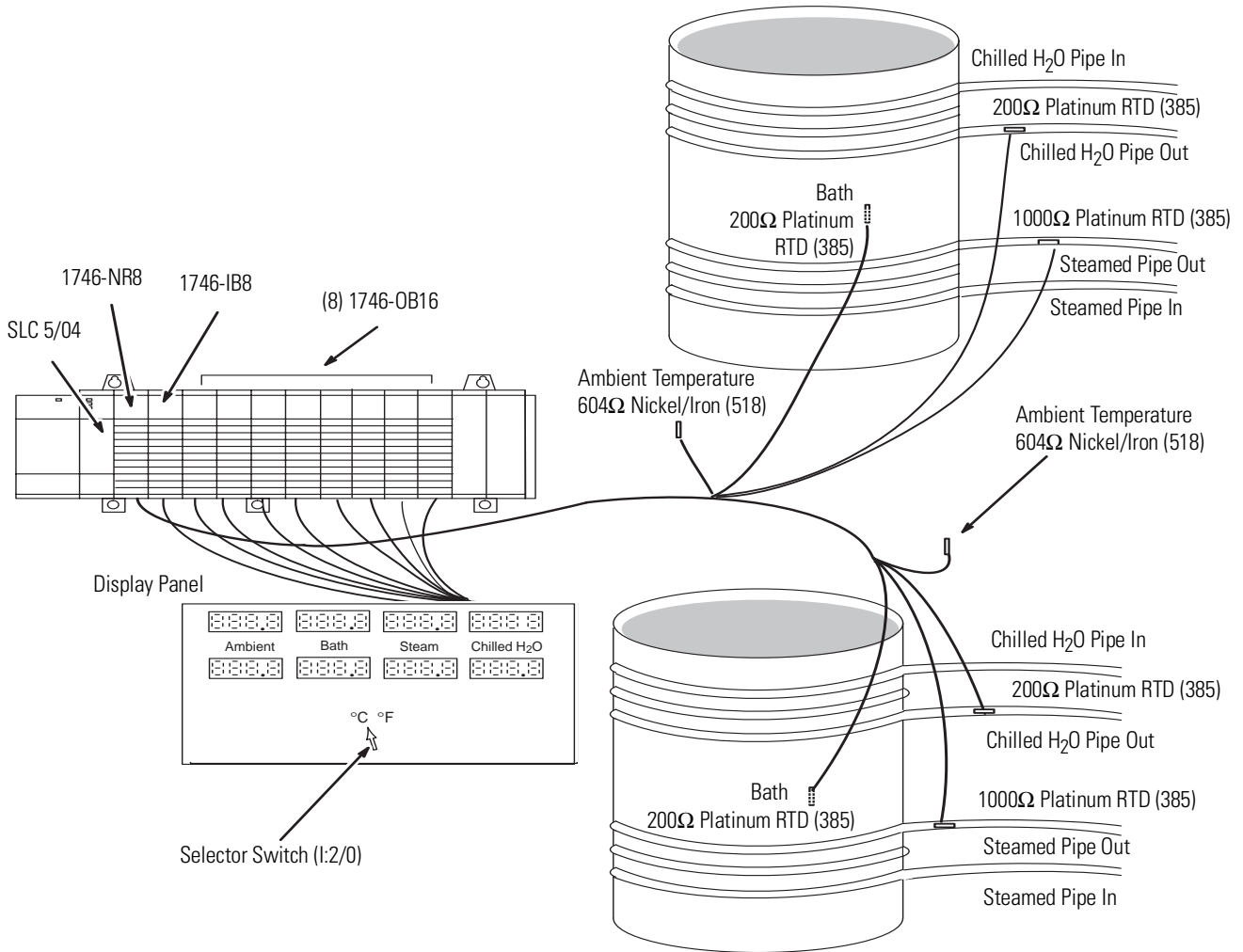

Channel Configuration

(see completed worksheet on page 7-5)

Configuration setup for ambient RTD:

- channels 0 and 4
- 604Ω Nickel/Iron (518)
- display temperature to tenths of a degree Celsius or Fahrenheit
- zero data word in the event of an open- or short-circuit
- 28 Hz input filter to provide 60 Hz line noise rejection
- use 1.0 mA excitation current for RTD
- scaling for -20°C to +60°C

Configuration setup for bath RTD:

- channels 1 and 5
- 200 Ω Platinum RTD (385)
- display temperature to tenths of a degree Celsius or Fahrenheit
- zero data word in the event of an open- or short-circuit
- 28 Hz input filter to provide 60 Hz line noise rejection
- use 1.0 mA excitation current for RTD
- scaling for 0°C to +60°C
- define upper and lower temperature limits

Configuration setup for steam RTD:

- channels 2 and 6
- 1000 Ω Platinum RTD (385)
- display temperature to tenths of a degree Celsius or Fahrenheit
- zero data word in the event of an open- or short-circuit
- 50/60 Hz input filter to provide 60 Hz line noise rejection
- use 0.25 mA excitation current for RTD
- scaling for -20°C to +200°C

Configuration setup for chilled H₂O RTD:

- channels 3 and 7
- 200 Ω Platinum RTD (385)
- display temperature to tenths of a degree Celsius or Fahrenheit
- zero data word in the event of an open- or short-circuit
- 28 Hz input filter to provide 60 Hz line noise rejection
- scaling for 0°C to +60°C
- define upper and lower temperature limits

Table 7.3 Channel Configuration Worksheet (With Settings Established)

Bit Definitions:						
Bits 0 through 3	Input Type Select	0000 = 100 Ω Pt. (385) 0001 = 200 Ω Pt. (385) 0010 = 500 Ω Pt. (385) 0011 = 1000 Ω Pt. (385) 0100 = 100 Ω Pt. (3916) 0101 = 200 Ω Pt. (3916)	0110 = 500 Ω Pt. (3916) 0111 = 1000 Ω Pt. (3916) 1000 = 10 Ω Cu (427) ⁽¹⁾ 1001 = 120 Ω Ni (618) ⁽²⁾ 1010 = 120 Ω Ni (617) 1011 = 604 Ω Ni-Fe (518)	1100 = 150 Ω Potentiometer 1101 = 500 Ω Potentiometer 1110 = 1000 Ω Potentiometer 1111 = 3000 Ω Potentiometer		
Bits 4 and 5	Data Format Select	00 = engineering units, x1 ⁽³⁾ 01 = engineering units, x10 ⁽⁴⁾		10 = scaled-for-PID (0 to 16383) 11 = proportional counts (-32768 to +32767)		
Bits 6 and 7	Broken Input Select	00 = zero	01 = upscale	10 = downscale	11 = Invalid	
Bit 8	Temperature Units Select	0 = degrees Celsius	1 = degrees Fahrenheit			
Bits 9 and 10	Filter Frequency Select	00 = 10 Hz	01 = 50 Hz	10 = 60 Hz	11 = 250 Hz	
Bit 11	Channel Enable	0 = channel disabled	1 = channel enabled			
Bit 12	Excitation Current Select	0 = 1.0 mA	1 = 0.25 mA			
Bit 13	Calibration Enable	0 = enable	1 = disabled			
Bits 14 and 15	Lead Res. Enable	00 = always	01 = periodic	10 = disable		

(1) Actual value at 0 °C is 9.042 Ω per SAMA standard RC21-4-1966.(2) Actual value at 0 °C is 100 Ω per DIN standard.(3) Values are in 0.1°/step or 0.1 Ω /step for all resistance input types, except 150 Ω . For the 150 Ω resistance input type, the values are in 0.01 Ω /step.(4) Values are in 1°/step or 1 Ω /step for all resistance input types, except 150 Ω . For the 150 Ω resistance input type, the values are in 0.1 Ω /step.

Program Setup and Operation Summary

1. The alarms section of the ladder program monitors for any out of range condition.
2. Set up two configuration words in memory for each channel, one for °C and the other for °F. The following table shows the configuration word allocation summary.

Table 7.4 Configuration Word Allocation

Channel	Configuration Word Allocation	
	°F	°C
0	N10:0	N10:8
1	N10:1	N10:9
2	N10:2	N10:10
3	N10:3	N10:11
4	N10:4	N10:12
5	N10:5	N10:13
6	N10:6	N10:14
7	N10:7	N10:15

3. When the position of the degrees selector switch changes, write the appropriate channel configuration to the RTD module. Note that the use of the OSR instruction (one-shot rising) makes these configuration changes edge-triggered, that is, the RTD is reconfigured only when the selector switch changes position.
4. Convert the individual RTD data words to BCD and send the data to the respective LED displays.

Program Listing

The first two rungs of this program send the correct channel setup information to the RTD module based on the position of the degrees selector switch.

Figure 7.4 Program to Display Data On LEDs

If the degrees selector switch is turned to the Fahrenheit position, set up all eight channels to read in degrees Fahrenheit.

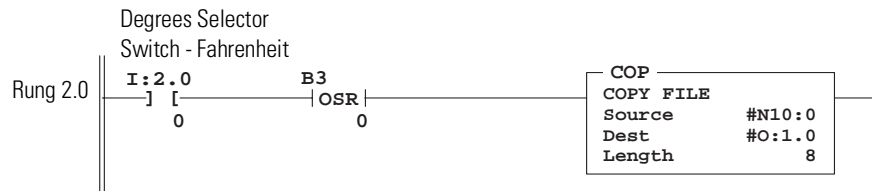

If the degrees selector switch is turned to the Celsius position, set up all four channels to read in degrees Celsius.

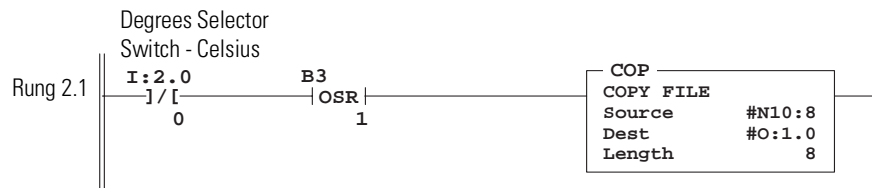

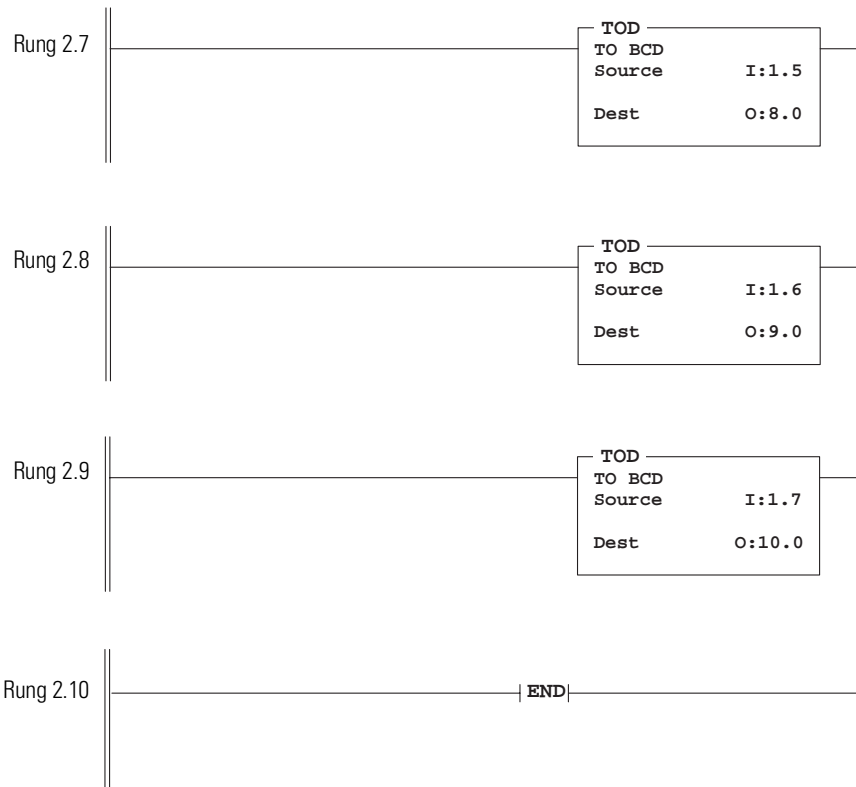

Table 7.5 Data Table

Address	15	14	13	12	11	10	9	8	7	6	5	4	3	2	1	0
N10:0	0	0	0	0	1	1	0	1	0	0	0	0	1	0	1	1
N10:1	0	0	0	0	1	1	0	1	0	0	0	0	1	1	1	0
N10:2	0	0	0	1	1	1	0	1	0	0	0	0	0	0	1	1
N10:3	0	0	0	0	1	1	0	1	0	0	0	0	1	1	1	1
N10:4	0	0	0	0	1	1	0	1	0	0	0	0	1	0	1	1
N10:5	0	0	0	0	1	1	0	1	0	0	0	0	1	1	1	0
N10:6	0	0	0	1	1	1	0	1	0	0	0	0	0	0	1	1
N10:7	0	0	0	0	1	1	0	1	0	0	0	0	1	1	1	1
N10:8	0	0	0	0	1	1	0	0	0	0	0	0	1	0	1	1
N10:9	0	0	0	0	1	1	0	0	0	0	0	0	0	0	0	1
N10:10	0	0	0	1	1	1	0	0	0	0	0	0	0	0	1	1
N10:11	0	0	0	0	1	1	0	0	0	0	0	0	0	0	0	1
N10:12	0	0	0	0	1	1	0	0	0	0	0	0	1	0	1	1
N10:13	0	0	0	0	1	1	0	0	0	0	0	0	0	0	0	1
N10:14	0	0	0	1	1	1	0	0	0	0	0	0	0	0	1	1
N10:15	0	0	0	0	1	1	0	0	0	0	0	0	0	0	0	1

Specifications

This appendix lists the specifications for the 1746-NR8 RTD Input Module.

Electrical Specifications

Backplane Current Consumption	100 mA at 5V dc 55 mA at 24V dc
Backplane Power Consumption	1.82W maximum (0.5W at 5V dc, 1.32W at 24V dc)
External Power Supply Requirements	None
Number of Channels	8 (backplane isolated)
I/O Chassis Location	Any I/O module slot except slot 0
A/D Conversion Method	Sigma-Delta Modulation
Input Filtering	Low pass digital filter with programmable notch (filter) frequencies
Common Mode Rejection (between inputs and chassis ground)	> 120 dB at 50 Hz (28 Hz and 50 Hz filter frequencies) > 120 dB at 60 Hz (28 Hz and 60 Hz filter frequencies)
Normal Mode Rejection (between [+] input and [-] input)	65 dB minimum at 50/60 Hz with 50/60 Hz filter 110 dB minimum at 50 Hz with 28 Hz filter 95 dB minimum at 60 Hz with 28 Hz filter
Max. common mode voltage	± 1 volt
Max. allowed permanent overload ⁽¹⁾	Volts = ± 5V dc; Current = ± 5 mA
Input Filter Cut-Off Frequencies	7.80 Hz at 28 Hz filter frequency 13.65 Hz at 50/60 Hz filter frequency 209.6 Hz at 800 Hz filter frequency 1676 Hz at 6400 Hz filter frequency
Calibration	Module autocalibrates when: <ul style="list-style-type: none"> power is provided to the module a channel is enabled a change is made to its input type, filter frequency or excitation current the periodic calibration disable is set to 0
Isolation (optical)	500V ac for 1 minute between inputs and chassis ground, and between inputs and backplane
Isolation Between Inputs	±5 V dc

(1) Do not apply a voltage or current to the module.

Physical Specifications

LED Indicators	9 green status indicators, one for each of 8 channels and one for module status
Module ID Code	3508 - Class 1 12708 - Class 3
Maximum Termination Wire Size	One 14 AWG wire per terminal
Maximum Cable Impedance	25 ohms maximum impedance for 3-wire RTD configuration
Terminal Block	1746-RT35

Environmental Specifications

Operating Temperature	0°C to +60°C (+32°F to +140°F)
Storage Temperature	-40°C to +85°C (-40°F to +185°F)
Relative Humidity	5% to 95% (without condensation)
Hazardous Environment Classification	Class I, Division 2
Agency Certification (when product or packaging is marked)	UL and CSA Class I, Division 2 Groups A, B, C, D certified CE compliant for all applicable directives

Input Specifications

RTD Types	platinum, nickel, nickel iron, copper (For additional information on RTD types, see page A-3.)
Temperature Scale (Selectable)	°C or °F and 0.1°C or 0.1°F
Resistance Scale (Selectable)	1Ω or 0.1Ω for all resistance ranges except 150Ω; or 0.1Ω or 0.01Ω for 150Ω potentiometer.
Input Step Response	See channel step response, page 3-5.
Input Resolution and Repeatability	See RTD and resistance device compatibility tables on page 1-3.
Display Resolution	See Channel Data Word Resolution table on page 4-14.
Module Update Time	See Chapter 3, Update Time, page 3-10.
Channel Turn-On Time	Requires up to one module update time plus 125 milliseconds x the number of unique input type and excitation current combinations.
Channel Turn-Off Time	Requires up to one module update time.
Reconfiguration Time	Requires up to one module update time plus 125 milliseconds x the number of unique input type and excitation current combinations.
RTD Excitation Current	Two current values are user-selectable: 0.25 mA - Recommended for use with higher resistance ranges for both RTDs and direct resistance inputs (1000Ω RTDs and 3000Ω resistance input). Refer to RTD manufacturer for recommendations. 1.0 mA - Recommended to use for all other RTD and direct resistance inputs, except 1000Ω RTDs and 3000Ω resistance input ranges are limited. Refer to RTD manufacturer for recommendations.

Module Accuracy

RTD Temperature Ranges, Resolution, and Repeatability

Input Type		Temp. Range (0.25 mA Excitation) ⁽⁴⁾	Temp. Range (1.0 mA Excitation) ⁽⁴⁾	Resolution	Repeatability (28 Hz, 50/60 Hz)
Platinum (385) ⁽¹⁾	100Ω	-200°C to +850°C (-328°F to +1562°F)	-200°C to +850°C (-328°F to +1562°F)	0.1°C (0.1°F)	± 0.2°C (± 0.4°F)
	200Ω	-200°C to +850°C (-328°F to +1562°F)	-200°C to +850°C (-328°F to +1562°F)	0.1°C (0.1°F)	± 0.2°C (± 0.4°F)
	500Ω	-200°C to +850°C (-328°F to +1562°F)	-200°C to +390°C (-328°F to +698°F)	0.1°C (0.1°F)	± 0.2°C (± 0.4°F)
	1000Ω	-200°C to +850°C (-328°F to +1562°F)	-200°C to +50°C (-328°F to +122°F)	0.1°C (0.1°F)	± 0.2°C (± 0.4°F)
Platinum (3916) ⁽¹⁾	Ω	-200°C to +630°C (-328°F to +1166°F)	-200°C to +630°C (-328°F to +1166°F)	0.1°C (0.1°F)	± 0.2°C (± 0.4°F)
	200Ω	-200°C to +630°C (-328°F to +1166°F)	-200°C to +630°C (-328°F to +1166°F)	0.1°C (0.1°F)	± 0.2°C (± 0.4°F)
	500Ω	-200°C to +630°C (-328°F to +1166°F)	-200°C to +380°C (-328°F to +698°F)	0.1°C (0.1°F)	± 0.2°C (± 0.4°F)
	1000Ω	-200°C to +630°C (-328°F to +1166°F)	-200°C to +50°C (-328°F to +122°F)	0.1°C (0.1°F)	± 0.2°C (± 0.4°F)
Copper (426) ⁽¹⁾⁽²⁾	10Ω	-100°C to +260°C (-328°F to +500°F)	-100°C to +260°C (-328°F to +500°F)	0.1°C (0.1°F)	± 0.2°C (± 0.4°F)
Nickel (618) ⁽¹⁾⁽³⁾	120Ω	-100°C to +260°C (-328°F to +500°F)	-100°C to +260°C (-328°F to +500°F)	0.1°C (0.1°F)	± 0.1°C (± 0.2°F)
Nickel (672) ⁽¹⁾	120Ω	-80°C to +260°C (-328°F to +500°F)	-80°C to +260°C (-328°F to +500°F)	0.1°C (0.1°F)	± 0.1°C (± 0.2°F)
Nickel Iron (518) ⁽¹⁾	604Ω	-200°C to +200°C (-328°F to +392°F)	-200°C to +180°C (-328°F to +338°F)	0.1°C (0.1°F)	± 0.1°C (± 0.2°F)

(1) The digits following the RTD type represent the temperature coefficient of resistance (α), which is defined as the resistance change per ohm per °C. For instance, Platinum 385 refers to a platinum RTD with $\alpha = 0.00385$ ohms/ohm · °C or simply 0.00385 /°C.

(2) Actual value at 0°C is 9.042Ω per SAMA standard RC21-4-1966.

(3) Actual value at 0°C is 100Ω per DIN standard.

(4) The temperature range for the 1000Ω RTD is dependent on the excitation current.

IMPORTANT

The exact signal range valid for each input type is dependent upon the excitation current magnitude that you select when configuring the module. For details on excitation current, refer to page A-2.

RTD Accuracy and Temperature Drift Specifications

Input Type		0.25 mA Excitation		1.0 mA Excitation	
		Accuracy ⁽¹⁾	Temperature Drift ⁽²⁾	Accuracy ⁽¹⁾	Temperature Drift ⁽²⁾
Platinum (385) ⁽³⁾	100Ω	±0.5°C (±0.9°F)	±0.012°C/°C (±0.012°F/°F)	±0.7°C (±1.3°F)	±0.020°C/°C (±0.020°F/°F)
	200Ω	±0.6°C (±1.1°F)	±0.015°C/°C (±0.015°F/°F)	±0.7°C (±1.3°F)	±0.020°C/°C (±0.020°F/°F)
	500Ω	±0.7°C (±1.3°F)	±0.020°C/°C (±0.020°F/°F)	±0.5°C (±0.9°F)	±0.012°C/°C (±0.012°F/°F)
	1000Ω	±1.2°C (±2.2°F)	±0.035°C/°C (±0.035°F/°F)	±0.4°C (±0.7°F)	±0.010°C/°C (±0.010°F/°F)
Platinum (3916) ⁽³⁾	10 Ω	±0.4°C (±0.7°F)	±0.010°C/°C (±0.010°F/°F)	±0.6°C (±1.1°F)	±0.015°C/°C (±0.015°F/°F)
	200Ω	±0.5°C (±0.9°F)	±0.011°C/°C (±0.011°F/°F)	±0.6°C (±1.1°F)	±0.015°C/°C (±0.015°F/°F)
	500Ω	±0.6°C (±1.1°F)	±0.015°C/°C (±0.015°F/°F)	±0.4°C (±0.7°F)	±0.012°C/°C (±0.012°F/°F)
	1000Ω	±0.9°C (±1.6°F)	±0.026°C/°C (±0.026°F/°F)	±0.3°C (±0.6°F)	±0.010°C/°C (±0.010°F/°F)
Copper (426) ^{(3) (4)}	10Ω	±0.5°C (±0.9°F)	±0.008°C/°C (±0.008°F/°F)	±0.8°C (±1.4°F)	±0.008°C/°C (±0.008°F/°F)
Nickel (618) ⁽³⁾⁽⁵⁾	120Ω	±0.2°C (±0.4°F)	±0.003°C/°C (±0.003°F/°F)	±0.2°C (±0.4°F)	±0.005°C/°C (±0.005°F/°F)
Nickel (672) ⁽³⁾	120Ω	±0.2°C (±0.4°F)	±0.003°C/°C (±0.003°F/°F)	±0.2°C (±0.4°F)	±0.005°C/°C (±0.005°F/°F)
Nickel Iron (518) ⁽³⁾	604Ω	±0.3°C (±0.5°F)	±0.008°C/°C (±0.008°F/°F)	±0.3°C (±0.5°F)	±0.008°C/°C (±0.008°F/°F)
Resistance ⁽³⁾	150Ω	±0.2Ω	±0.004Ω/°C (±0.002Ω/°F)	±0.15Ω	±0.003Ω/°C (±0.002Ω/°F)
	500Ω	±0.5Ω	±0.012Ω/°C (±0.007Ω/°F)	±0.5Ω	±0.012Ω/°C (±0.007Ω/°F)
	1000Ω	±1.0Ω	±0.025Ω/°C (±0.014Ω/°F)	±1.0Ω	±0.025Ω/°C (±0.014Ω/°F)
	3000Ω	±1.5Ω	±0.040Ω/°C (±0.023Ω/°F)	±1.2Ω	±0.040Ω/°C (±0.023Ω/°F)

(1) The accuracy values assume that the module was calibrated within the specified temperature range of 0°C to +60°C (+32°F to +140°F).

(2) Temperature drift specifications apply to a module that has not been calibrated.

(3) The digits following the RTD types represent the temperature coefficient of resistance (α), which is defined as the resistance change per ohm per °C. For instance, Platinum 385 refers to a Platinum RTD with $\alpha = 0.00385 \Omega/\Omega\text{-}^\circ\text{C}$ or simply 0.00385/°C.

(4) Actual value at 0°C is 9.042Ω per SAMA standard RC21-4-1966.

(5) Actual value at 0°C is 100Ω per DIN standard.

Resistance Device Compatibility

Table A.1 Resistance Input Specifications

Input Type		Resistance Range (0.25 mA Excitation)	Resistance Range (1.0 mA Excitation)	Resolution	Repeatability (28 Hz, 50/60 Hz)
Resistance	150Ω	0 to 150Ω	Ω	0.01Ω	± 0.04Ω
	500Ω	0 to 500Ω	Ω	0.1Ω	± 0.2Ω
	1000Ω	0 to 1000Ω	Ω	0.1Ω	± 0.2Ω
	3000Ω	0 to 3000Ω	Ω	0.1Ω	± 0.2Ω

Cable Specifications

Description	Belden #9501	Belden #9533	Belden #83503
When used	For 2-wire RTDs and potentiometers.	For 3-wire RTDs and potentiometers. Short runs less than 100 feet and normal humidity levels.	For 3-wire RTDs and potentiometers. Long runs greater than 100 feet or high humidity levels.
Conductors	2, #24 AWG tinned copper (7× 32)	3, #24 AWG tinned copper (7× 32)	3, #24 AWG tinned copper (7× 32)
Shield	Beldfoil aluminum polyester shield with copper drain wire.	Beldfoil aluminum polyester shield with copper drain wire.	Beldfoil aluminum polyester shield with tinned braid shield.
Insulation	PVC	S-R PVC	Teflon
Jacket	Chrome PVC	Chrome PVC	Red teflon
Agency Approvals	NEC Type CM	NEC Type CM	NEC Art-800, Type CMP
Temperature Rating	80°C	80°C	200°C

RTD Standards

RTD Type	α ⁽¹⁾	(2)	(3)	(4)	(5)	(6)	(7)	(8)
100Ω Platinum	0.00385	X	X				X	
200Ω Platinum	0.00385	X	X				X	
500Ω Platinum	0.00385	X	X				X	
1000Ω Platinum	0.00385	X	X				X	
100Ω Platinum	0.03916			X		X		
200Ω Platinum	0.03916			X		X		
500Ω Platinum	0.03916			X		X		
1000Ω Platinum	0.03916			X		X		
10Ω Copper ⁽⁹⁾	0.00426				X			
120Ω Nickel ⁽¹⁰⁾	0.00618		X					
120Ω Nickel	0.00672							X
604Ω Nickel Iron	0.00518							X

(1) α is the temperature coefficient of resistance which is defined as the resistance change per ohm per °C.

(2) International Electrotechnical Commission Standard 751-1983

(3) German Standard, DIN 43760-1980 and DIN 43760-1987

(4) U.S. Standard D100

(5) Scientific Apparatus Makers Association Standard RC21-4-1966

(6) Japanese Industrial Standard JIS C1604-1981

(7) Japanese Standard JIS C1604-1989

(8) Minco Type 'NA' (Nickel) and Minco Type 'FA' (Nickel-Iron)

(9) Actual value at 0°C is 9.042Ω per SAMA standard RC21-4-1966.

(10) Actual value at 0°C is 100Ω per DIN standard.

ATTENTION



We recommend you use RTDs that conform to the standards in the table above. Failure to heed this caution may result in reduced accuracy of the RTD system.

Configuration Worksheet for RTD/Resistance Module

See Chapter 4 for worksheet procedure.

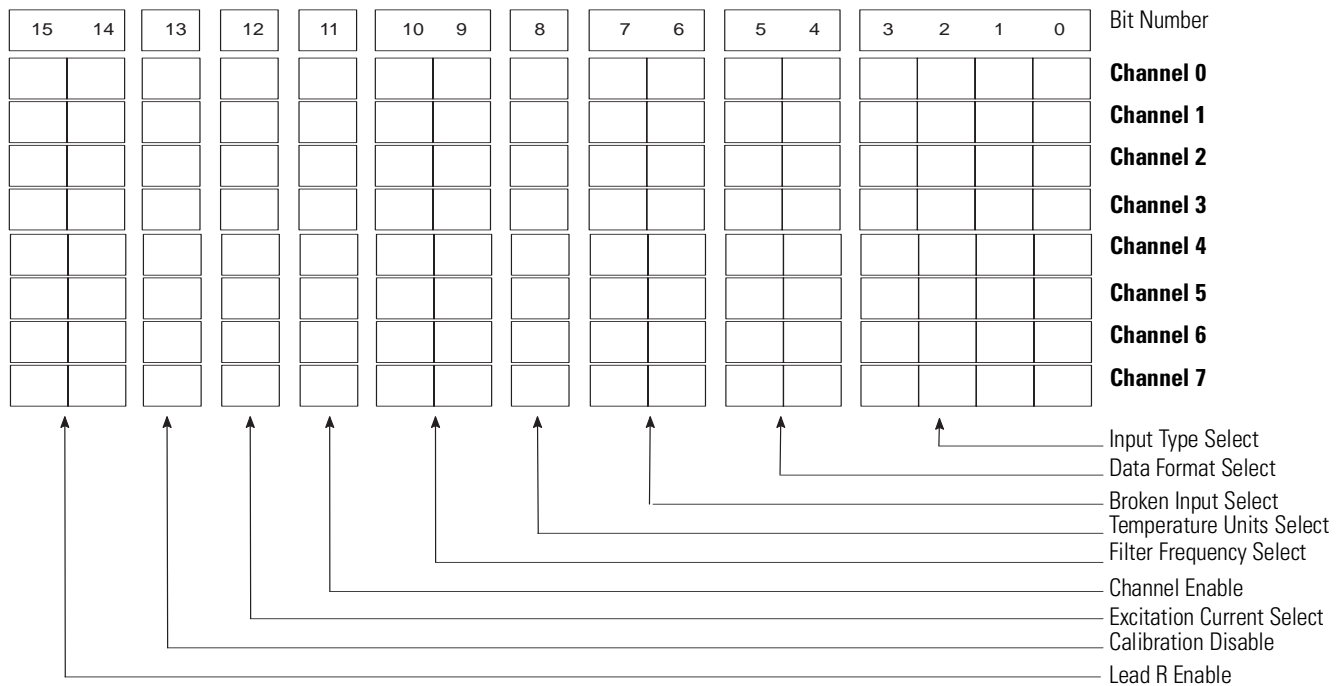

Bit Definitions:

Bits 0 through 3	Input Type Select	0000 = 100Ω Pt. (385) 0001 = 200Ω Pt. (385) 0010 = 500Ω Pt. (385) 0011 = 1000Ω Pt. (385) 0100 = 100Ω Pt. (3916) 0101 = 200Ω Pt. (3916)	0110 = 500Ω Pt. (3916) 0111 = 1000Ω Pt. (3916) 1000 = 10Ω Cu (426) ⁽¹⁾ 1001 = 120Ω Ni (618) ⁽²⁾ 1010 = 120Ω Ni (672) 1011 = 604Ω Ni-Fe (518)	1100 = 150Ω Potentiometer 1101 = 500Ω Potentiometer 1110 = 1000Ω Potentiometer 1111 = 3000Ω Potentiometer	
Bits 4 and 5	Data Format Select	00 = engineering units, x1 ⁽³⁾ 01 = engineering units, x10 ⁽⁴⁾	10 = scaled-for-PID (0 to 16383) 11 = proportional counts (-32768 to +32767)		
Bits 6 and 7	Broken Input Select	00 = zero	01 = upscale	10 = downscale	11 = Invalid
Bit 8	Temperature Units Select	0 = degrees Celsius	1 = degrees Fahrenheit		
Bits 9 and 10	Filter Frequency Select	00 = 28 Hz	01 = 50/60 Hz	10 = 800 Hz	11 = 6400 Hz
Bit 11	Channel Enable	0 = channel disabled	1 = channel enabled		
Bit 12	Excitation Current Select	0 = 1.0 mA	1 = 0.25 mA		
Bit 13	Cal. Disable	0 = enable calibration (default)	1 = disable calibration		
Bits 14 and 15	Lead R Enable	00 = Disable, 01 = Periodic, 10 = Always, 11 = Invalid			

(1) Actual value at °C is 9.042Ω per SAMA standard RC21-4-1966.

(2) Actual value at 0°C is 100Ω per DIN standard.

(3) Values are in 0.1° /step or 0.1 Ω /step for all resistance input types, except 150Ω. For the 150Ω resistance input type, the values are in 0.01Ω /step.

(4) Values are in 1° /step or 1Ω /step for all resistance input types, except 150Ω. For the 150Ω resistance input type, the values are in 0.1Ω /step.

The following terms and abbreviations are specific to this product. For a complete listing of Allen-Bradley terminology, refer to the *Allen-Bradley Industrial Automation Glossary*, Publication Number AG-7.1.

A/D - Refers to the analog-to-digital converter inherent to the RTD/Resistance input module. The converter produces a digital value whose magnitude is proportional to the instantaneous magnitude of an analog input signal.

attenuation - The reduction in the magnitude of a signal as it passes through a system.

channel - Refers to one of four small-signal analog input interfaces available on the module's terminal block. Each channel is configured for connection to an RTD or potentiometer input device and has its own diagnostic status word.

chassis - A hardware assembly that houses devices such as I/O modules, adapter modules, processor modules, and power supplies.

common mode rejection ratio - The ratio of a device's differential voltage gain to common mode voltage gain, expressed in dB.

$$\text{CMRR} = 20 \text{ Log}_{10} (V_1/V_2)$$

common mode voltage - A voltage signal induced in conductors with respect to ground (0 potential).

configuration word - Contains the channel configuration information needed by the module to configure and operate each channel. Information is written to the configuration word through the logic supplied in your ladder program.

cut-off frequency - The frequency at which the input signal is attenuated 3dB by the digital filter. Frequency components of the input signal below the cut-off frequency are passed with under 3dB of attenuation.

data word - A 16-bit integer that represents the value of the analog input channel. The channel data word is valid only when the channel is enabled and there are no channel errors. When the channel is disabled, the channel data word is cleared (0).

dB (decibel) - A logarithmic measure of the ratio of two signal levels.

digital filter - A low-pass noise filter incorporated into the A/D converter. In addition, the digital filter provides high-rejection notches at frequencies that are integral multiples of the filter cut-off frequency. The notches are used for rejecting AC power line noise and higher frequency noise.

excitation current - A user-selectable current (0.25 mA and 1.0 mA) that the module sends through the RTD or resistive device to produce an analog signal which the NR8 can process and convert to temperature or to ohms, respectively.

effective resolution - The amount of jitter (data variation) that typically occurs in the data word due to the influence of the internal electrical noise in the module.

filter frequency - The user-selectable stop-band frequency for the A/D converter's digital filter. The digital filter provides AC power line noise rejection when the first notch is at 10 Hz or at the power line frequency.

full scale error (gain error) - The difference in slope between the actual and ideal potentiometer or RTD transfer functions.

full scale range (FSR) - The difference between the maximum and minimum specified analog RTD or resistive input values.

gain drift - The change in full scale transition voltage measured over the operating temperature range of the module.

input data scaling - The data formats that you select to define the logical increments of the channel data word. These may be scaled-for-PID, or Engineering Units for RTD or potentiometer inputs, which are automatically scaled. They may also be proportional counts, which you must calculate to fit your application's temperature or resistance resolution.

local configuration - A control system where all the chassis are located within several feet of the processor and chassis-to-chassis communication is via a 1746-C7 or 1746-C9 ribbon cable.

LSB (Least Significant Bit) - Refers to a data increment defined as the full scale range divided by the resolution. The LSB represents the smallest value within a string of bits.

multiplexer - A switching system that allows several input signals to share a common A/D converter.

normal mode rejection (differential mode rejection) - A logarithmic measure in dB, of a device's ability to reject noise signals between or among circuit signal conductors, but not between equipment grounding conductor or signal reference structure and the signal conductors.

potentiometer (Pot) - A variable resistor that can be connected to the RTD module.

remote configuration - A control system where the chassis can be located several thousand feet from the processor chassis. Chassis communication is via the 1747-SN Scanner and 1747-ASB Remote I/O Adapter.

resolution - The smallest detectable change in a measurement, typically expressed in engineering units (e.g., 0.1 °C) or as a number of bits. For example, a 12-bit system has 4,096 possible output states. It can, therefore, measure 1 part in 4096.

RTD (Resistance Temperature Detector) - A temperature sensing element with 2, 3 or 4 lead wires. It uses the basic characteristic that electrical resistance of metals increases with temperature. When a small current is applied to the RTD, it creates a voltage that varies with temperature. This voltage is processed and converted by the RTD module into a temperature value.

sampling time - The time required by the A/D converter to sample an input channel.

status word - Contains status information about the channel's current configuration and operational state. You can use this information in your ladder program to determine whether the channel data word is valid.

step response time - This is the time required for the A/D input signal to reach 100% of its expected final value, given a large step change in the input signal.

update time - The time required for the module to sample and convert the input signals of all enabled input channels and make the resulting data values available to the SLC processor.

A

A/D *G-1*
abbreviations *G-1*
addressing
 configuration word *3-4*
 addressing example *3-4*
 data word
 addressing example *3-5*
 status word *3-4*
 addressing example *3-5*
Allen-Bradley *P-3*
 contacting for assistance *P-3*
application examples *7-1*
attenuation *G-1*

B

bit allocation *4-5*
 in configuration word *4-5*
broken circuit
 defining conditional state of channel data
 downscale enable *4-16*
 upscale enable *4-16*
 zero *4-16*
broken input
 bit description in configuration word *4-16*
 bit description in status word *4-22*
broken input error
 bit description in status word *4-23*

C

cable specifications *A-5*
cable tie slots *1-6*
calibration
 auto cal *2-15*
 factory cal *2-15*
 single-point *2-16*
channel
 configuration error *6-4*
 bit description in status word *4-24*
 definition *G-1*
channel status bit *4-23*
 bit description in status word *4-23*
channel timing
 channel scan time *3-10*
 channel update time *3-10*
chassis *G-1*
CMRR *G-1*
common mode rejection ratio *G-1*
common mode voltage *G-1*

compatibility *1-3*
configuration word *3-4, G-1*
 factory default setting *4-3*
 worksheet *B-1*
configuring a channel
 worksheet *B-1*
contacting Allen-Bradley for assistance *P-3*
current consumption *2-3*
cut-off frequency *3-7, G-1*

D

data word *G-1*
data word format *4-6*
 bit description in configuration word *4-6*
 bit description in status word *4-22*
dB *G-1*
decibel *G-1*
default setting of configuration word *4-3*
definitions *G-1*
diagnostics *6-1*
differential mode rejection See normal mode rejection *G-3*
digital filter *G-2*
disabling a channel *4-17*
door label *1-6*

E

effective resolution
 definition *G-2*
electrical noise *2-5*
enabling a channel *4-17*
 bit description in configuration word *4-17*
engineering units input *4-6*
error codes *6-3*
errors *6-4*
 detecting channel-related errors *6-4*
 configuration error *6-4*
 open circuit *6-4*
 over-range error *6-5*
 under-range error *6-5*
 detecting module-related errors *6-5*
 conditions tested at power-up *6-5*
 over-range error *6-5*
examples
 how to address configuration word *3-4*
 how to address data word *3-5*
 how to address status word *3-5*
excitation current *4-23, G-2*
 bit description in status word *4-23*
 definition *G-2*

specifications *A-2*

F

filter frequency *G-2*
 bit description in configuration word *4-17*
 bit description in status word *4-23*
full scale error *G-2*
full scale range *G-2*

G

gain drift *G-2*
gain error *G-2*
gain error See full scale error *G-2*
grounding
 cable shield *2-9*
 guidelines *2-9*

H

hardware overview *1-5*
heat considerations *2-5*

I

ID code *3-1*
input channel multiplexing *1-8*
input data scaling *G-2*
input device type *4-6*
 bit description in configuration word *4-6*
 bit description in status word *4-22*
input filter See filter frequency *G-2*
input response to slot disabling *3-12*
installation *2-1, 2-7*
 heat and noise considerations *2-5*
 in modular chassis *2-3*

L

LED indicators *1-5*
 channel status *1-6*
 module status *1-6*
 state tables *6-3*
local configuration *G-2*
LSB *G-2*

M

manuals
 related *P-2*
module ID code

 how to enter *3-1*
module operation *1-8*
module to processor communication
 channel data word *1-10*
multiplexing *1-8*
multiplexor *G-2*

N

normal mode rejection *G-3*

O

open-circuit *6-4*
 error condition *6-4*
out-of-range error *6-5*
 over-range error
 fault bit *4-24*
 under-range error *4-23*
 fault bit *4-23*
output image *3-4*
output response to slot disabling *3-12*
over-range error *4-24*

P

PID input type *4-6*
PID instruction
 application example *5-5*
 programming *5-5*
pot
 definition *G-3*
potentiometer
 2-wire pot interconnection *2-12*
 3-wire pot interconnection *2-12*
 ohmic values *1-5*
 repeatability *1-5*
 wiring diagram *2-12*
 wiring inputs *2-11, 2-14*
power-up sequence *1-8*
programming
 application examples *7-1*
 configuration settings *5-2*
 initial setting *5-2*
 making changes *5-4*
 proportional counts data format *5-7*
proportional counts data format
 application example *5-7*
proportional counts input *4-6*
publications
 related *P-2*

R

- remote configuration *G-3*
- removable terminal block *1-6*
- removing the module *2-7*
- removing the terminal block *2-6*
- resistance device types
 - ohmic values *1-5*
 - potentiometers *1-5*
- resolution *3-6, G-3*
- routing of wires *2-9*
- RTD
 - definition *G-3*
 - excitation current
 - definition and values *G-2*
- RTD Temperature Ranges, Resolution, and Repeatability *A-3*

S

- sampling time *G-3*
- scaled-for-PID *4-6*
- scaling *4-10*
- scaling input data *G-2*
- scanning process
 - scanning cycle *3-10*
 - update time *3-10*
- self-locking tabs *1-6*
- specifications *A-1*
 - cable *A-5*
- standards
 - for RTDs *A-5*
- status word *G-3*

- step response *3-5, G-3*
- system operation *1-7*

T

- temperature units *4-17*
 - bit description in configuration word *4-17*
 - bit description in status word *4-22*
- terms *G-1*
- torque *2-9*
 - terminal block screws *2-9*
- troubleshooting *6-1*
 - contacting Allen-Bradley *P-3*
 - flowchart *6-7*
 - LED examination *6-2*
- turn-on time *3-12*

U

- under-range error *4-23*
 - fault bit *4-23*
- update time *G-3*
 - channel update time *3-10*
 - module update time *3-10*

V

- Verification of dynamic configuration change *5-4*

W

- wiring *2-1*
 - routing of wires *2-9*

Reach us now at www.rockwellautomation.com

Wherever you need us, Rockwell Automation brings together leading brands in industrial automation including Allen-Bradley controls, Reliance Electric power transmission products, Dodge mechanical power transmission components, and Rockwell Software. Rockwell Automation's unique, flexible approach to helping customers achieve a competitive advantage is supported by thousands of authorized partners, distributors and system integrators around the world.

Americas Headquarters, 1201 South Second Street, Milwaukee, WI 53204, USA, Tel: (1) 414 382-2000, Fax: (1) 414 382-4444
European Headquarters SA/NV, avenue Herrmann Debroux, 46, 1160 Brussels, Belgium, Tel: (32) 2 663 06 00, Fax: (32) 2 663 06 40
Asia Pacific Headquarters, 27/F Citicorp Centre, 18 Whitfield Road, Causeway Bay, Hong Kong, Tel: (852) 2887 4788, Fax: (852) 2508 1846

Publication 1746-UM003A-EN-P - June 2000

